

		PAGINA Page Seite
<p>MODULO MOTORIZZATO RADIALE Radial driven tool Radial angetriebenes Werkzeug</p>		MZK010.1.00
<p>MODULO MOTORIZZATO RADIALE MTSK Radial MTSK driven tool Radial MTSK angetriebenes Werkzeug</p>		MZK010.1.00.K
<p>MODULO MOTORIZZATO RADIALE DISASSATO IN Z 50mm Radial driven tool re-directed in Z by 50mm Radial angetriebenes Werkzeug achsversetzt in Z um 50mm</p>		MZK030.1.10
<p>MODULO MOTORIZZATO RADIALE RIDOTTO I=2:1 DISASSATO IN Z 50mm Radial geared-down I=2:1 driven tool re-directed in Z by 50mm Radial angetriebenes Werkzeug untersetzt I=2:1 achsversetzt in Z um 50mm</p>		MZK030.1.20
<p>MODULO MOTOR. RADIALE MOLTIPLICATO I=1:2 DISASSATO IN Z 50mm Radial geared-up I=1:2 driven tool re-directed in Z by 50mm Radial angetriebenes Werkzeug uebersetzt I=1:2 achsversetzt in Z um 50mm</p>		MZK030.1.30
<p>MODULO MOTORIZZATO RADIALE MAGGIORATO DISASSATO IN Z 50mm Radial reinforced driven tool re-directed in Z by 50mm Radial angetriebenes Werkzeug vergroesset achsversetzt in Z um 50mm</p>		MZK031.1.10
<p>MODULO MOTORIZZATO RADIALE MAGGIORATO RIDOTTO I=2:1 DISASSATO IN Z 50mm Radial reinforced geared-down I=2:1 driven tool re-directed in Z by 50mm Radial angetriebenes Werkzeug vergroesset untersetzt I=2:1 achsversetzt in Z um 50mm</p>		MZK031.1.20
<p>MODULO MOTORIZZ. RADIALE MAGGIORATO MOLTIPLICATO I=1:2 DISASSATO IN Z 50mm Radial reinforced geared-up I=1:2 driven tool re-directed in Z by 50mm Radial angetriebenes Werkzeug vergroesset uebersetzt I=1:2 achsversetzt in Z um 50mm</p>		MZK031.1.30
<p>MODULO MOTORIZZATO RADIALE 2 USCITE IN Y Radial single side twin head driven tool in Y Radial angetriebenes Werkzeug 2 Ausgaenge in Y</p>		MZK080.1.00
<p>MODULO MOTORIZZATO RADIALE DISASSATO 50mm ORIENTABILE ±25° Radial ±25° adjustable angle driven tool re-directed by 50mm Radial angetriebenes Werkzeug schwenkbar ±25° achsversetzt um 50mm</p>		MZK135.1.00
<p>MODULO MOTORIZZATO ASSIALE H=80mm Axial driven tool H=80mm Axial angetriebenes Werkzeug H=80mm</p>		MZK150.1.10
<p>MODULO MOTORIZZATO ASSIALE H=130mm Axial driven tool H=130mm Axial angetriebenes Werkzeug H=130mm</p>		MZK150.1.20

		PAGINA Page Seite
<p>MODULO MOTORIZZATO ASSIALE MTSK Axial MTSK driven tool Axial MTSK angetriebenes Werkzeug</p>		MZK150.1.20.K
<p>MODULO MOTORIZZATO ASSIALE MOLTIPLICATO I=1:3 Axial geared-up I=1:3 driven tool Axial angetriebenes Werkzeug uebersetzt I=1:3</p>		MZK208.1.10
<p>MODULO MOTORIZZATO ASSIALE BISPORGENTE Axial opposite face twin driven tool Axial angetriebenes Werkzeug halb vorspringend</p>		MZK240.1.10
<p>MODULO MOTORIZZATO ASSIALE ARRETRATO BISPORGENTE Axial opposite face rear-set driven tool Axial angetriebenes Werkzeug zurueckversetzt halb vorspringend</p>		MZK243.1.10
<p>MODULO MOTORIZZATO ASSIALE BISPORGENTE MOLTIPLICATO I=1:2 Axial geared-up I=1:2 opposite face twin driven tool Axial angetriebenes Werkzeug halb vorspringend uebersetzt I=1:2</p>		MZK250.1.00
<p>MODULO MOTORIZZATO ASSIALE BISPORGENTE MOLTIPLICATO I=1:2 Axial geared-up I=1:2 opposite face twin driven tool Axial angetriebenes Werkzeug halb vorspringend uebersetzt I=1:2</p>		MZK250.1.10
<p>MODULO MOTORIZZATO ORIENTABILE ±90° ±90° adjustable angle driven tool Angetriebenes Werkzeug schwenkbar ±90°</p>		MZK333.1.00
<p>MODULO MOTORIZZATO ORIENTABILE ±90° CON NONIO DIGITALE ±90° adjustable angle driven tool with digital display Angetriebenes Werkzeug schwenkbar ±90° mit digital display</p>		MZK333.1.01
<p>MODULO MOTORIZZATO ORIENTABILE ±90° ±90° adjustable angle driven tool Angetriebenes Werkzeug schwenkbar ±90°</p>		MZK335.1.00
<p>MODULO MOTORIZZATO ORIENTABILE ±90° CON NONIO DIGITALE ±90° adjustable angle driven tool with digital display Angetriebenes Werkzeug schwenkbar ±90° mit digital display</p>		MZK335.1.01
<p>MODULO MOTORIZZATO ORIENTABILE ±90° MOLTIPLICATO I=1:2 ±90° adjustable angle driven tool geared-up I=1:2 Angetriebenes Werkzeug schwenkbar ±90° uebersetzt I=1:2</p>		MZK336.1.00
<p>MODULO MOTOR. ORIENTABILE ±90° MOLTIPL. I=1:2 CON NONIO DIGITALE ±90° adjustable angle driven tool geared-up I=1:2 with digital display Angetriebenes Werkzeug schwenkbar ±90° uebersetzt I=1:2 mit digital display</p>		MZK336.1.01

		PAGINA Page Seite
<p>MODULO MOTORIZZATO STOZZATORE CORSA 50mm H=130mm Slotting driven tool 50mm stroke H=130mm Keilnutenstossmaschine 50mm Hub H=130mm</p>		MZK360.1.00
<p>MODULO MOTORIZZATO STOZZATORE CORSA 25mm H=130mm Slotting driven tool 25mm stroke H=130mm Keilnutenstossmaschine 25mm Hub H=130mm</p>		MZK360.1.01
<p>PORTAUTENSILE RADIALE SINGOLO QD=25mm / QD=1" Radial single static tool QD=25mm / QD=1" Radial Single-Werkzeughalter QD=25mm / QD=1"</p>		MZK423.1.00
<p>PORTAUTENSILE RADIALE SOVRAPPOSTO QD=25mm Radial single side twin static tool QD=25mm Radial Werkzeughalter ueberlagert QD=25mm</p>		MZK442.1.00
<p>PORTAUTENSILE RADIALE DOPPIO QD=25mm / QD=1" Radial double static tool QD=25mm / QD=1" Radial Doppel-Werkzeughalter QD=25mm / QD=1"</p>		MZK453.1.00
<p>PORTAUTENSILE PER LAMA DOPPIO Radial double blade holder Radial Doppel-Abstechhalter</p>		MZK520.1.00
<p>PORTAUTENSILE PER LAMA DOPPIO CON LUBRIFICAZIONE INTERNA Radial double blade holder with internal coolant Radial Doppel-Abstechhalter mit Innenkuehlung</p>		MZK520.1.04
<p>PORTAUTENSILE ASSIALE SINGOLO QD=25mm / QD=1" Axial single static tool QD=25mm / QD=1" Axial Single-Werkzeughalter QD=25mm / QD=1"</p>		MZK552.1.00
<p>PORTAUTENSILE ASSIALE PER BARENO Ø40mm /Ø1 1/2" H=130mm Axial single boring bar holder Ø40mm /Ø1 1/2" H=130mm Axial Bohrhalter Ø40mm /Ø1 1/2" H=130mm</p>		MZK630.1.20
<p>PORTAUTENSILE ASSIALE PER BARENO Ø40mm /Ø1 1/2" H=140mm Axial single boring bar holder Ø40mm /Ø1 1/2" H=140mm Axial Bohrhalter Ø40mm /Ø1 1/2" H=140mm</p>		MZK640.1.10
<p>PORTAUTENSILE ASSIALE PER BARENO 2 POSIZIONI IN Y Ø32mm Axial double boring bar holder 2 positions in Y Ø32mm Axial Bohrhalter 2 Positionen in Y Ø32mm</p>		MZK866-1-40
<p>PORTAUTENSILE ASSIALE PER BARENO 3+3 POSIZIONI Ø25mm Axial 3+3 position boring bar holder Ø25mm Axial Bohrhalter 3+3 Positionen Ø25mm</p>		MZK912.1.00

		PAGINA Page Seite
<p>MODULO MOTORIZZATO RADIALE DISASSATO IN Z 50mm MT CAPTO Radial driven tool re-directed in Z by 50mm MT CAPTO Radial angetriebenes Werkzeug achsversetzt in Z um 50mm MT CAPTO</p>		MZK030.A.40
<p>MODULO MOTORIZZATO ASSIALE MT CAPTO Axial driven tool MT CAPTO Axial angetriebenes Werkzeug MT CAPTO</p>		MZK150.A.45
<p>MODULO MOTORIZZATO ASSIALE ARRETRATO BISPORGENTE MT CAPTO Axial opposite face rear-set driven tool MT CAPTO Axial angetriebenes Werkzeug zurueckversetzt halb vorspringend MT CAPTO</p>		MZK243.A.40
<p>PORTAUTENSILE ASSIALE SINGOLO MT CAPTO Axial single static tool MT CAPTO Axial Single-Werkzeughalter MT CAPTO</p>		MZK550.A.40

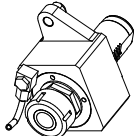
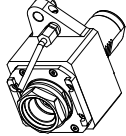
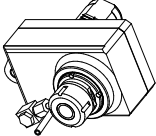
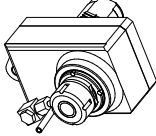
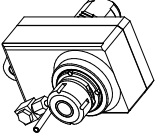
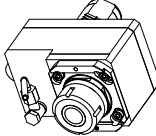
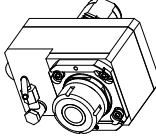
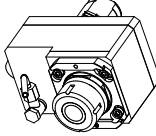
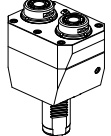
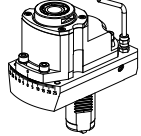
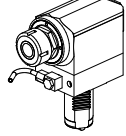
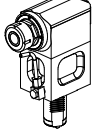
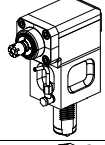
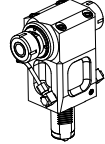
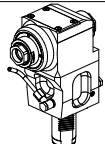
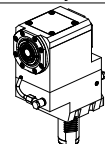
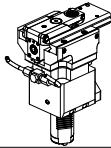
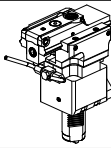
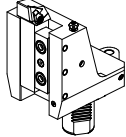
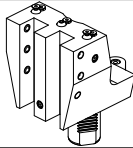
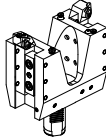
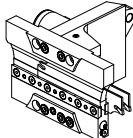
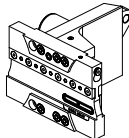
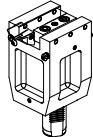
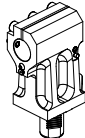
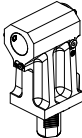
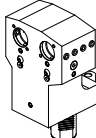
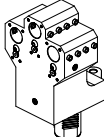
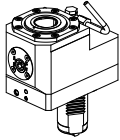
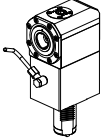
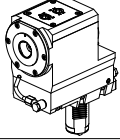
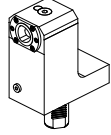
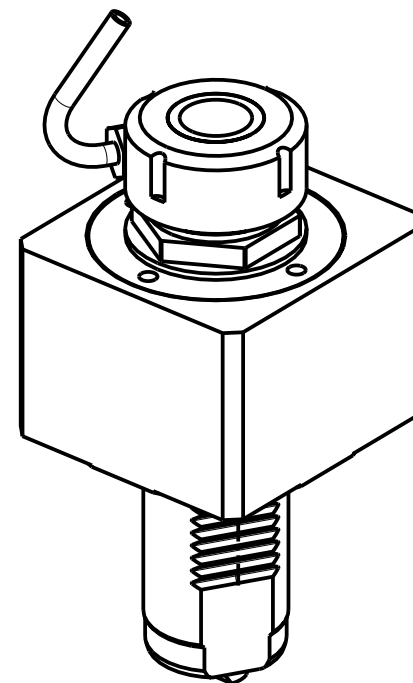
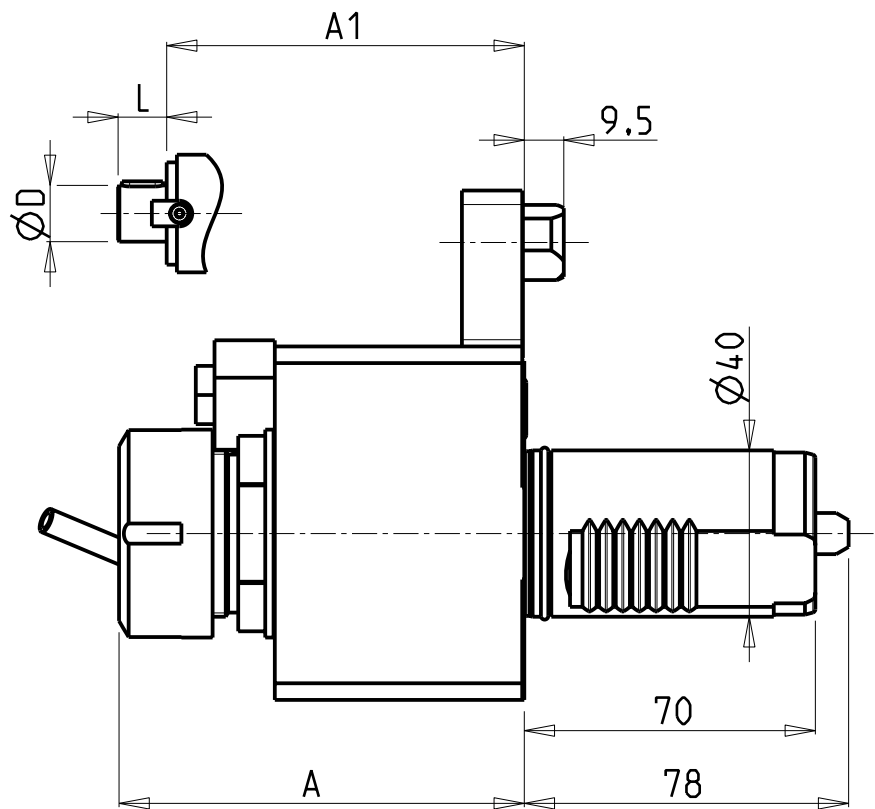
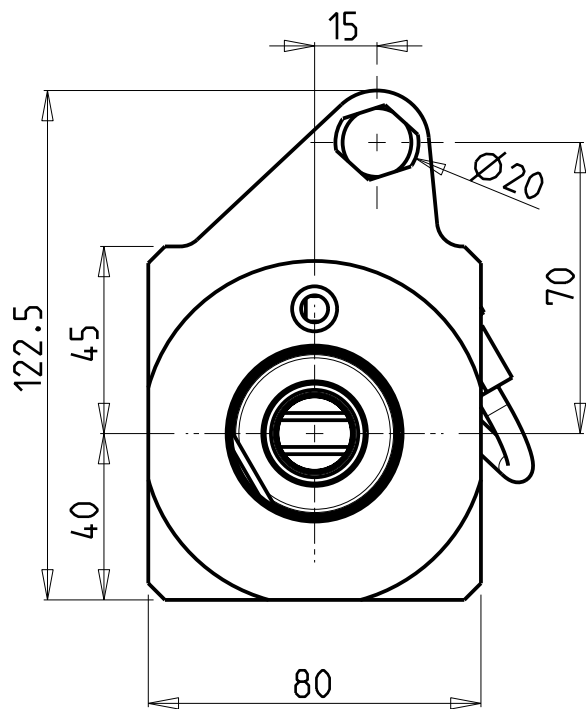

- Chiave inclusa
- Key included
- Schlüssel inbegriffen

Cod. MT	Mandrino Spindel Spindel	I	RPM	Coppia Max Max Torque Max Drehmoment	Lubrificazione int. Coolant through Innenkuehlung	Lubrificazione est. Ext. coolant Aussenkuehlung	A	A1	D	L	CHIAVI NON INCLUSE Keys not included Schlüssel nicht einbegriffen	
MZK0090232	ER32	1:1	6000	70Nm	-	X	97.46	-	-	-	CHUB46	CHSTER32
MZK1060232	ER32	1:1	6000	70Nm	P=70bar	X	112.46	-	-	-	OKU0650004	CHSTER32
MZK0090225	ER A 25	1:1	6000	70Nm	-	X	83.33	-	-	-	CHUB40	CHUB27
MZK0092219	Ø22x19	1:1	6000	70Nm	-	X	-	98.8	22	19	CHUB41	CH_VTCROCE_M10

MAZAK
 SQT 15-18M/MS/MY/MSY 12 STAZIONI - SQT200-250M/MS/MY/MSY 12 STAZIONI - QT NEXUS 200-250M/MS/MY/MSY 12 STAZIONI
 QT NEXUS 20011-25011 M/MS/MY/MSY 12 STAZIONI - SUPER QUADREX 200-250M - IVS200/300M

MODULO MOTORIZZATO RADIALE
 Radial driven tool
 Radial angetriebenes Werkzeug

Subject to change without notice.

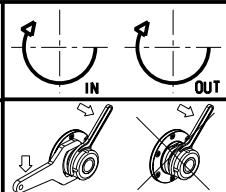

M.T. srl
 Via Casino Albini 480
 Tel. 0541/956034-957884
 Fax 0541/956341
 47842 S. GIOVANNI IN M. (RN)
 e-mail: mtma@mtmarchetti.com
 http://www.mtmarchetti.com



PAGINA MZK010-1-00

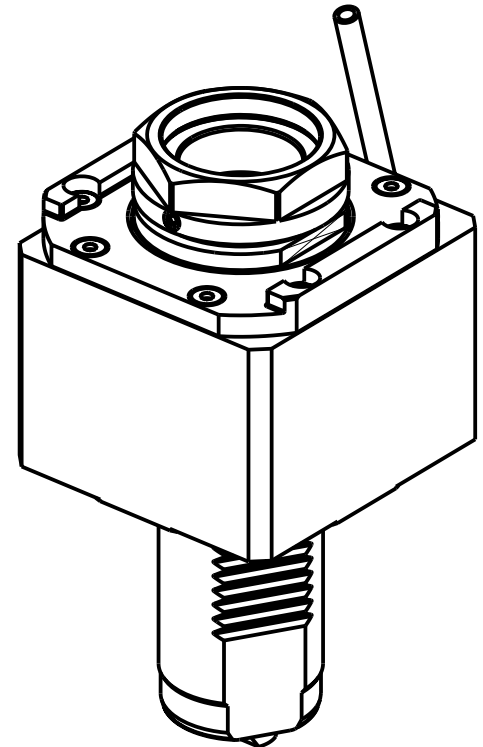
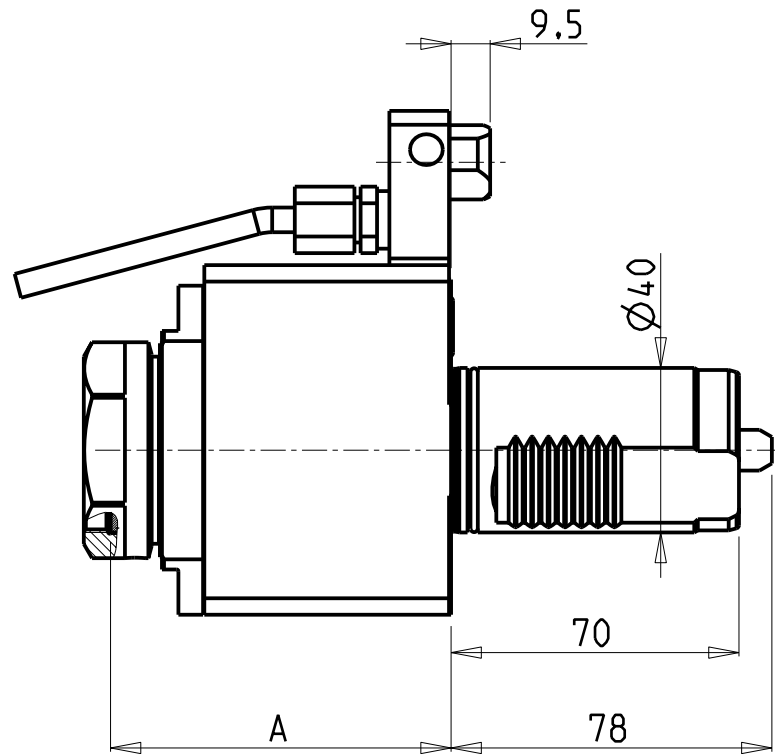
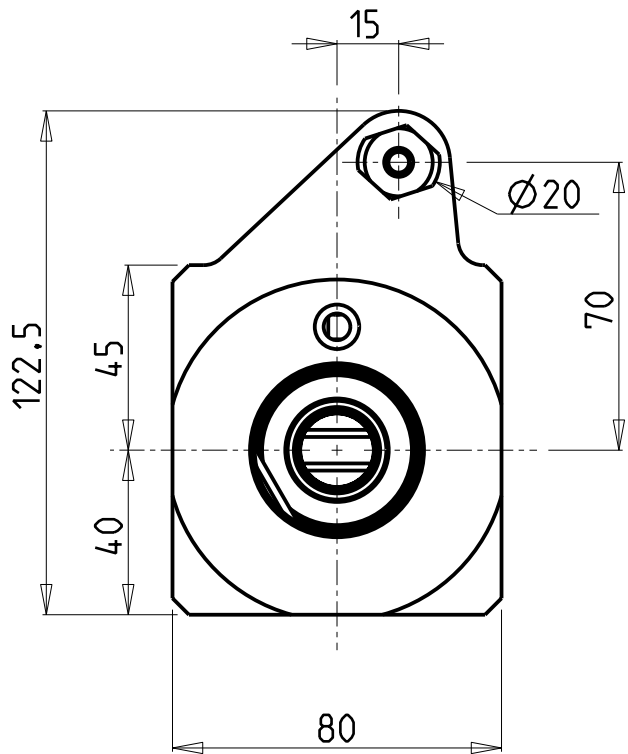

- Chiave inclusa
- Key included
- Schlüssel inbegriffen

PER PORTAUTENSILI MODULARI MTSK-40 VEDI PAG. TBL300-1-40
 FOR MTSK-40 QUICK CHANGE TOOLHOLDERS CLAMPINGS SEE PAGE TBL300-1-40
 FUER MTSK-40 MODULARE WERKZEUGAUFNAHMEN SIEHE SEITE TBL300-1-40

Cod. MT	Mandrino Spindle Spindel	I	RPM	Coppia Max Max Torque Max Drehmoment	Lubrificazione int. Coolant through Innenkuehlung	Lubrificazione est. Ext. coolant Aussenkuehlung	A	CHIAVI NON INCLUDE Keys not included Schlüssel nicht einbegriffen	
MZK0640140	MTSK-40	1:1	6000	70Nm	-	X	82.8	CHUB46	OKU0650004 *
MZK0640240	MTSK-40	1:1	6000	70Nm	P=30bar	X	95.8	CHUB46	OKU0650004 *

MAZAK
 SQT 15-18M/MS/MY/MSY 12 STAZIONI - SQT200-250M/MS/MY/MSY 12 STAZIONI - QT NEXUS 200-250M/MS/MY/MSY 12 STAZIONI
 QT NEXUS 20011-25011 M/MS/MY/MSY 12 STAZIONI - SUPER QUADREX 200-250M - IVS200/300M

MODULO MOTORIZZATO RADIALE MTSK
 Radial MTSK driven tool
 Radial MTSK angetriebenes Werkzeug

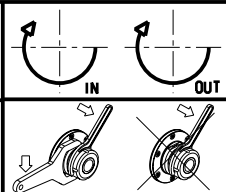

M.T. srl
 Via Casino Albini 480
 Tel. 0541/956034-957884
 Fax 0541/956341
 47842 S. GIOVANNI IN M. (RN)
 e-mail: mtma@mtmarchetti.com
 http://www.mtmarchetti.com



PAGINA MZK010-1-00-K

Subject to change without notice.

09/2022

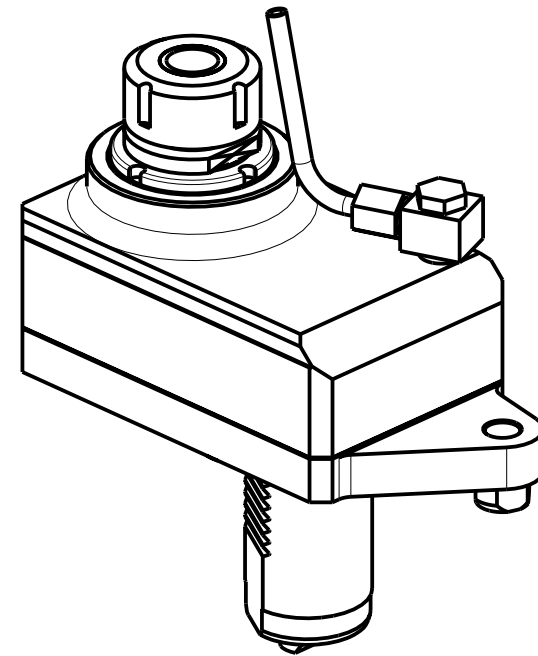
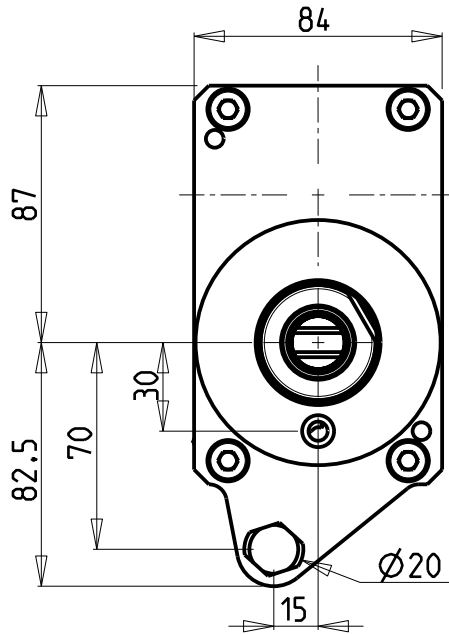
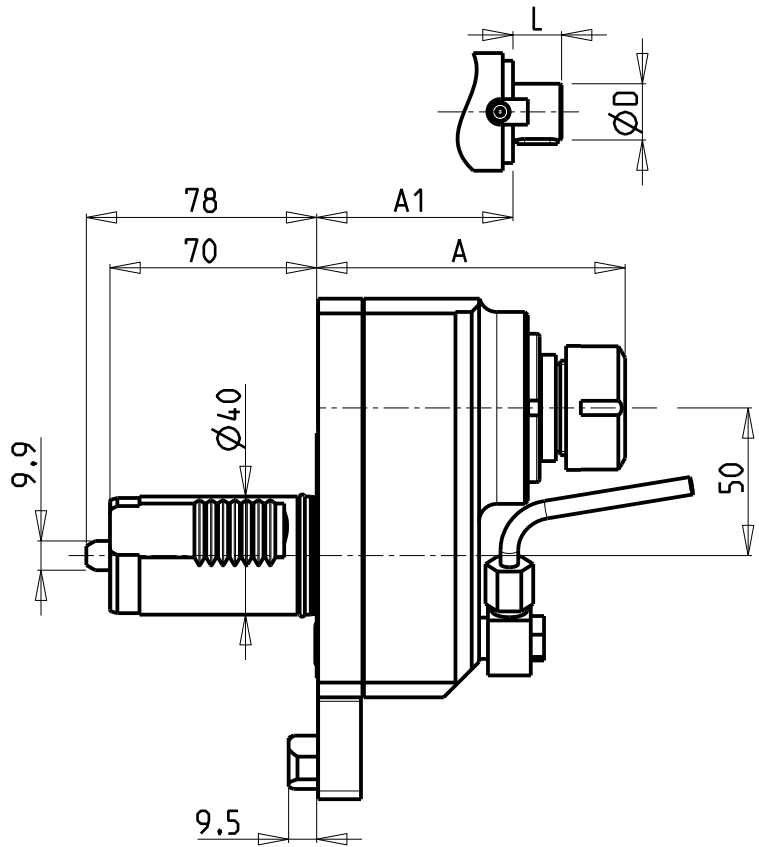

Cod. MT	Mandrino Spindle Spindel	I	RPM	Coppia Max Max Torque Max Drehmoment	Lubrificazione est. Ext. coolant Ausenkühlung	A	A1	D	L	CHIAVI NON INCLUSE Keys not included Schlüssel nicht einbegriffen	
MZK0010025	ER25	1:1	6000	70Nm	X	106.1	-	-	-	CHUB36	CHSTER25
MZK0010032	ER32	1:1	6000	70Nm	X	118.1	-	-	-	CHUB36	CHSTER32
MZK0010017	Ø16x17	1:1	6000	70Nm	X	-	86	16	17	CHUB36	CH_VTCROCE_M08
MZK0010019	Ø22x19	1:1	6000	70Nm	X	-	88	22	19	CHUB36	CH_VTCROCE_M10
MZK0010027	Ø27x21	1:1	6000	70Nm	X	-	90	27	21	CHUB36	CH_VTCROCE_M12

- Chiave inclusa
- Key included
- Schlüssel inbegriffen

MAZAK
 SQT 15-18M/MS/MY/MSY 12 STAZIONI - SQT200-250M/MS/MY/MSY 12 STAZIONI - QT NEXUS 200-250M/MS/MY/MSY 12 STAZIONI
 QT NEXUS 20011-25011 M/MS/MY/MSY 12 STAZIONI - SUPER QUADREX 200-250M - IVS200/300M

MODULO MOTORIZZATO RADIALE DISASSATO IN Z 50mm
 Radial driven tool re-directed in Z by 50mm
 Radial angetriebenes Werkzeug achsversetzt in Z um 50mm

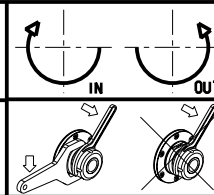

M.T. srl
 Via Casino Albini 480
 Tel. 0541/956034-957884
 Fax 0541/956341
 47842 S. GIOVANNI IN M. (RN)
 e-mail: mtma@mtmarchetti.com
 http://www.mtmarchetti.com



PAGINA MZK030-1-10

Subject to change without notice.

09/2022

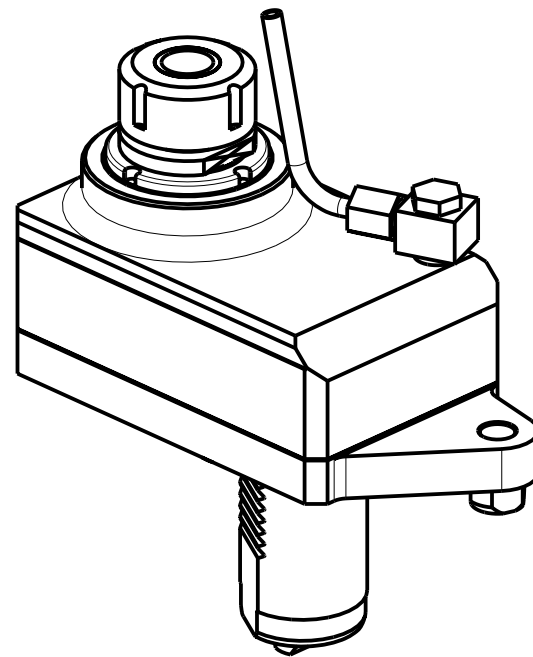
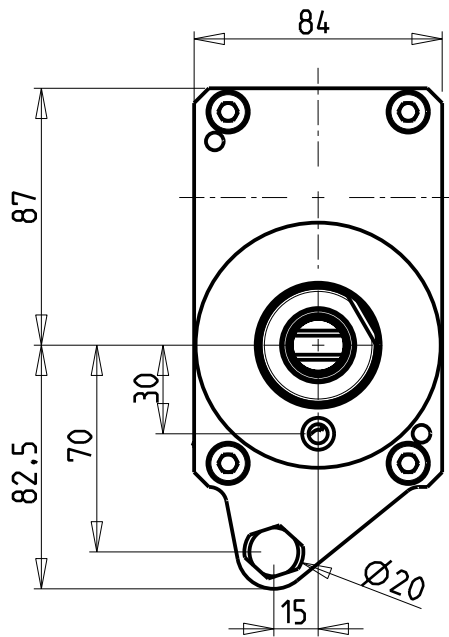
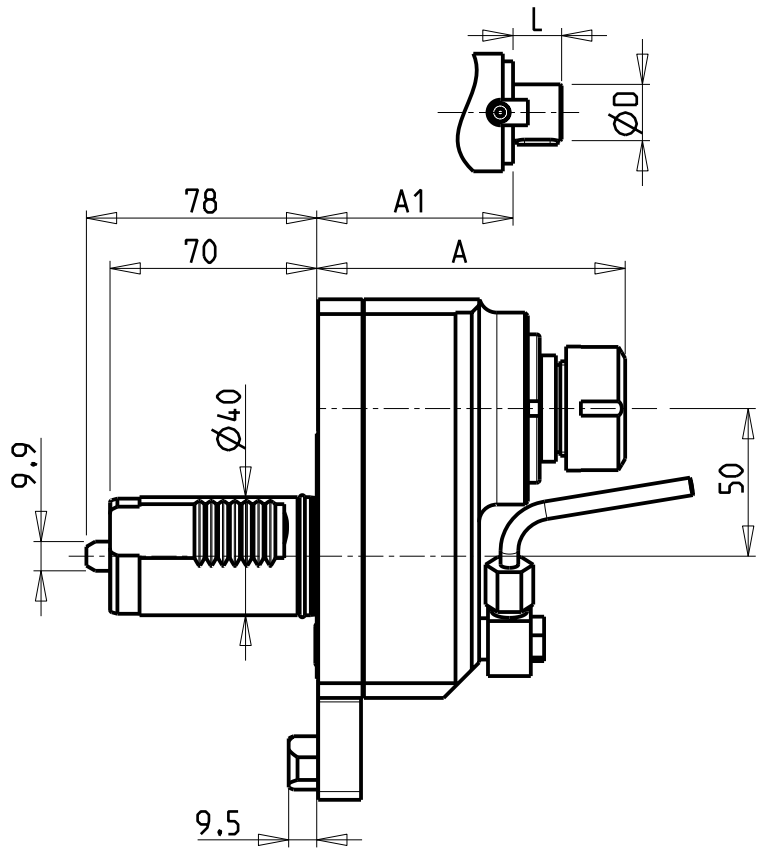

Cod. MT	Mandrino Spindle Spindel	I	RPM	Coppia Max Max Torque Max Drehmoment	Lubrificazione est. Ext. coolant Aussenkühlung	A	A1	D	L	CHIAVI NON INCLUDE Keys not included Schlüssel nicht einbegriffen	
MZK0011232	ER32	2:1	3000	80Nm	X	118.1	-	-	-	CHUB36	CHSTER32
MZK0011227	Ø27x21	2:1	3000	80Nm	X	-	90	27	21	CHUB36	CH_VTCROCE_M12

- Chiave inclusa
- Key included
- Schlüssel inbegriffen

MAZAK
 SQT 15-18M/MS/MY/MSY 12 STAZIONI - SQT200-250M/MS/MY/MSY 12 STAZIONI - QT NEXUS 200-250M/MS/MY/MSY 12 STAZIONI
 QT NEXUS 20011-25011 M/MS/MY/MSY 12 STAZIONI - SUPER QUADREX 200-250M - IVS200/300M

MODULO MOTORIZZATO RADIALE RIDOTTO I=2:1 DISASSATO IN Z 50mm
 Radial geared-down I=2:1 driven tool re-directed in Z by 50mm
 Radial angetriebenes Werkzeug untersetzt I=2:1 achsversetzt in Z um 50mm

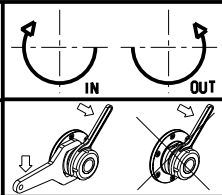

M.T. srl
 Via Casino Albini 480
 Tel. 0541/956034-957884
 Fax 0541/956341
 47842 S. GIOVANNI IN M. (RN)
 e-mail: mtma@mtmarchetti.com
 http://www.mtmarchetti.com



PAGINA MZK030-1-20

Subject to change without notice.

09/2022

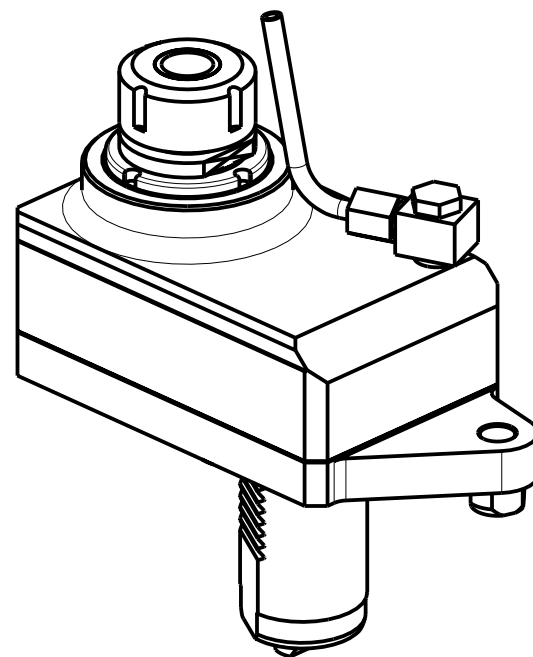
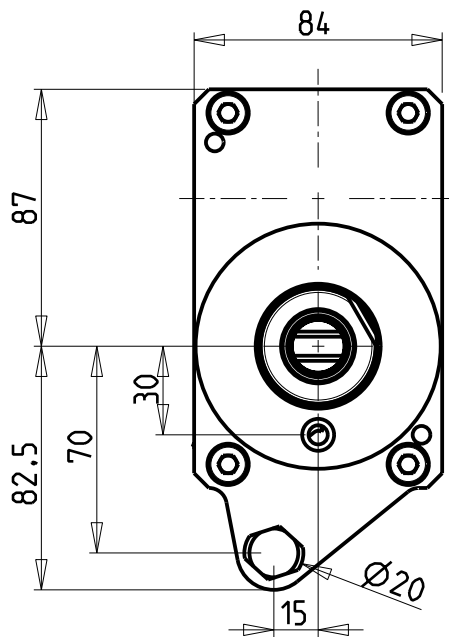
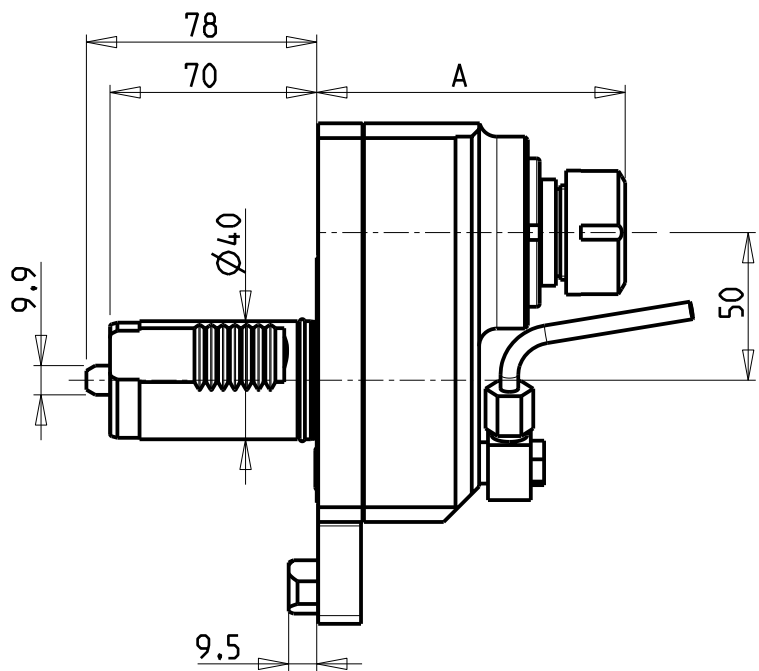

Cod. MT	Mandrino Spindle Spindel	I	RPM	Coppia Max Max Torque Max Drehmoment	Lubrificazione est. Ext. coolant Aussenkühlung	A	CHIAVI NON INCLUSE Keys not included Schlüssel nicht einbegriffen	
MZK0012125	ER25	1:2	12000	40Nm	X	106.2	CHUB36	CHSTER25
MZK0012132	ER32	1:2	12000	40Nm	X	118.7	CHUB36	CHSTER32

MAZAK

SQT 15-18M/MS/MY/MSY 12 STAZIONI - SQT200-250M/MS/MY/MSY 12 STAZIONI - QT NEXUS 200-250M/MS/MY/MSY 12 STAZIONI
 QT NEXUS 20011-25011 M/MS/MY/MSY 12 STAZIONI - SUPER QUADREX 200-250M - IVS200/300M

MODULO MOTORIZZATO RADIALE MOLTIPLICATO I=1:2 DISASSATO IN Z 50mm

Radial geared-up I=1:2 driven tool re-directed in Z by 50mm

Radial angetriebenes Werkzeug uebersetzt I=1:2 achsversetzt in Z um 50mm

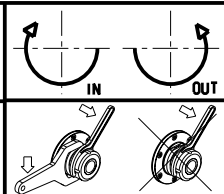

M.T. srl

Via Casino Albini 480
 Tel. 0541/956034-957884
 Fax 0541/956341

47842 S. GIOVANNI IN M. (RN)
 e-mail: mtma@tmarchetti.com
 http://www.tmmarchetti.com



PAGINA MZK030-1-30

Subject to change without notice.

09/2022

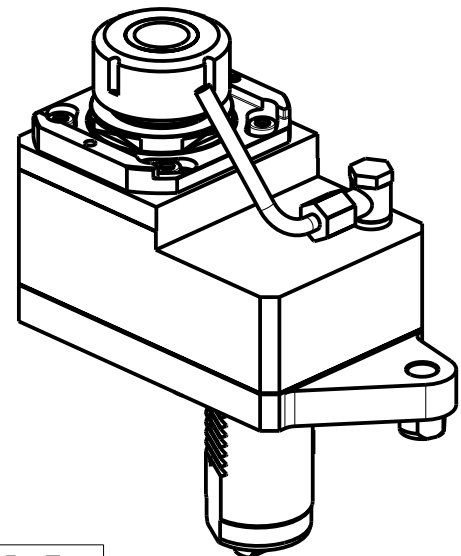
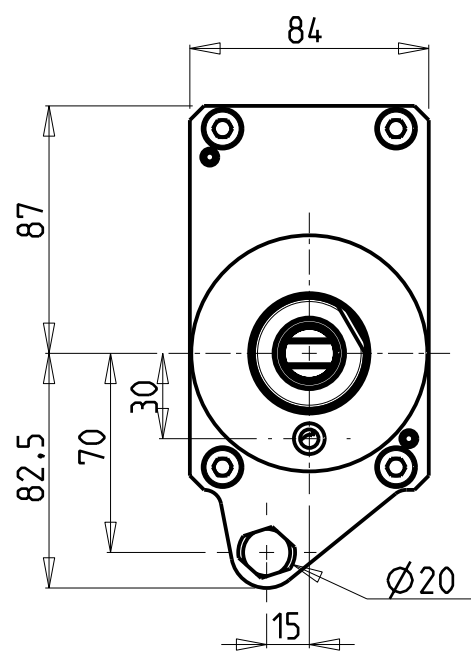
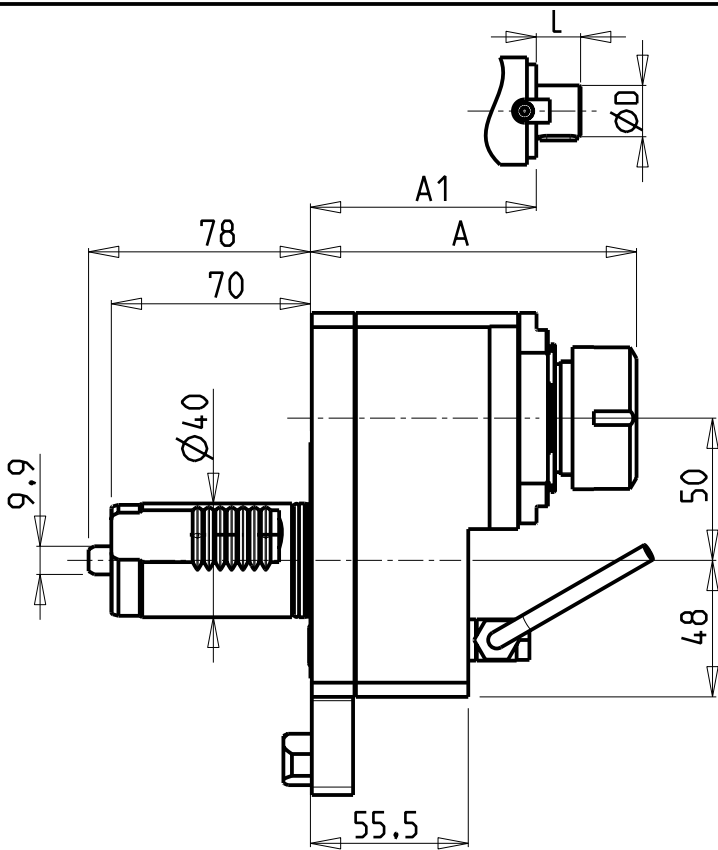

CUSCINETTI MAGGIORATI
PER LAVORAZIONI PESANTI

Reinforced bearings for
heavy machining

Vergroesserte Lager fuer
schwerere Bearbeitungen

- Chiave inclusa
- Key included
- Schluessel inbegriffen

Cod. MT	Mandrino Spindle Spindel	I	RPM	Coppia Max Max Torque Max Drehmoment	Lubrificazione est. Ext. coolant Ausseinkuhlung	A	A1	D	L	CHIAVI NON INCLUSE Keys not included Schluessel nicht einbegriffen	
MZK0241125	ER25	1:1	6000	70Nm	X	111.6	-	-	-	OKU0650004	CHSTER25
MZK0241132	ER32	1:1	6000	70Nm	X	114.6	-	-	-	OKU0650004	CHSTER32
MZK0241116	Ø16x17	1:1	6000	70Nm	X	-	88	16	17	OKU0650004	CH_VTCROCE_M08
MZK0241122	Ø22x19	1:1	6000	70Nm	X	-	90	22	19	OKU0650004	CH_VTCROCE_M10
MZK0241127	Ø27x21	1:1	6000	70Nm	X	-	92	27	21	OKU0650004	CH_VTCROCE_M12

MAZAK
 SQT 15-18M/MS/MY/MSY 12 STAZIONI - SQT200-250M/MS/MY/MSY 12 STAZIONI - QT NEXUS 200-250M/MS/MY/MSY 12 STAZIONI
 QT NEXUS 20011-25011 M/MS/MY/MSY 12 STAZIONI - SUPER QUADREX 200-250M - IVS200/300M

MODULO MOTORIZZATO RADIALE MAGGIORATO DISASSATO IN Z 50mm
 Radial reinforced driven tool re-directed in Z by 50mm
 Radial angetriebenes Werkzeug vergroessert achsversetzt in Z um 50mm

Subject to change without notice.

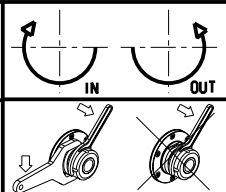

M.T. srl
 Via Casino Albini 480
 Tel. 0541/956034-957884
 Fax 0541/956341
 47842 S. GIOVANNI IN M. (RN)
 e-mail: mtma@mtmarchetti.com
 http://www.mtmarchetti.com



PAGINA MZK031-1-10

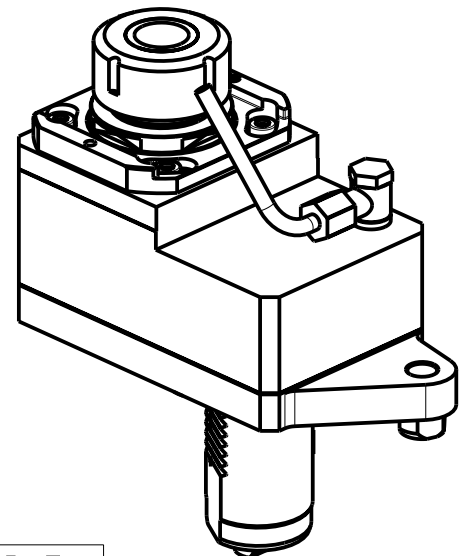
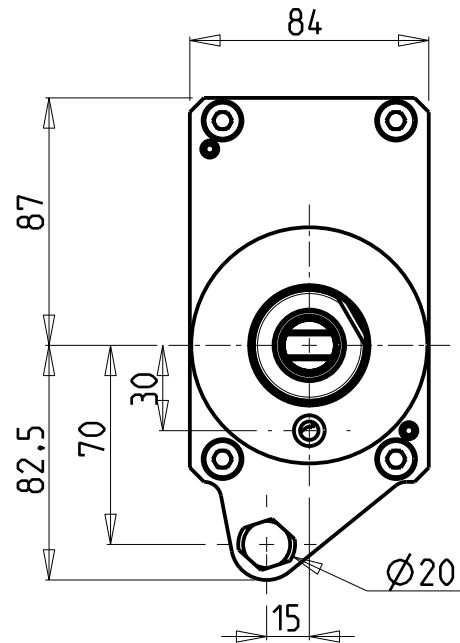
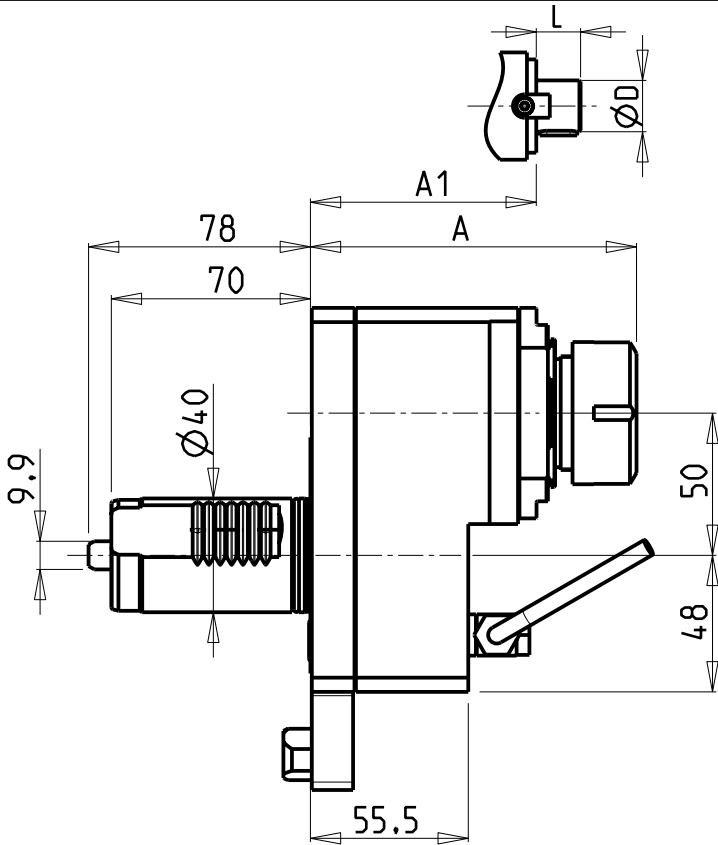

CUSCINETTI MAGGIORATI
PER LAVORAZIONI PESANTI

Reinforced bearings for
heavy machining

Vergroesserte Lager fuer
schwerere Bearbeitungen

- Chiave inclusa
- Key included
- Schluessel inbegriffen

Cod. MT	Mandrino Spindle Spindel	I	RPM	Coppia Max Max Torque Max Drehmoment	Lubrificazione est. Ext. coolant Ausseenkuehlung	A	A1	D	L	CHIAVI NON INCLUSE Keys not included Schluessel nicht einbegriffen	
MZK0241225	ER25	2:1	3000	80Nm	X	111.6	-	-	-	OKU0650004	CHSTER25
MZK0241232	ER32	2:1	3000	80Nm	X	114.6	-	-	-	OKU0650004	CHSTER32
MZK0241216	Ø16x17	2:1	3000	80Nm	X	-	88	16	17	OKU0650004	CH_VTCROCE_M08
MZK0241222	Ø22x19	2:1	3000	80Nm	X	-	90	22	19	OKU0650004	CH_VTCROCE_M10
MZK0241227	Ø27x21	2:1	3000	80Nm	X	-	92	27	21	OKU0650004	CH_VTCROCE_M12

MAZAK
 SQT 15-18M/MS/MY/MSY 12 STAZIONI - SQT200-250M/MS/MY/MSY 12 STAZIONI - QT NEXUS 200-250M/MS/MY/MSY 12 STAZIONI
 QT NEXUS 20011-25011 M/MS/MY/MSY 12 STAZIONI - SUPER QUADREX 200-250M - IVS200/300M

MODULO MOTORIZZATO RADIALE MAGGIORATO RIDOTTO I=2:1 DISASSATO IN Z 50mm
 Radial reinforced geared-down I=2:1 driven tool re-directed in Z by 50mm
 Radial angetriebenes Werkzeug vergroessert unterersetzt I=2:1 achsversetzt in Z um 50mm

Subject to change without notice.

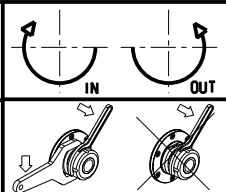

M.T. srl
 Via Casino Albini 480
 Tel. 0541/956034-957884
 Fax 0541/956341
 47842 S. GIOVANNI IN M. (RN)
 e-mail: mtma@mtmarchetti.com
 http://www.mtmarchetti.com



PAGINA MZK031-1-20

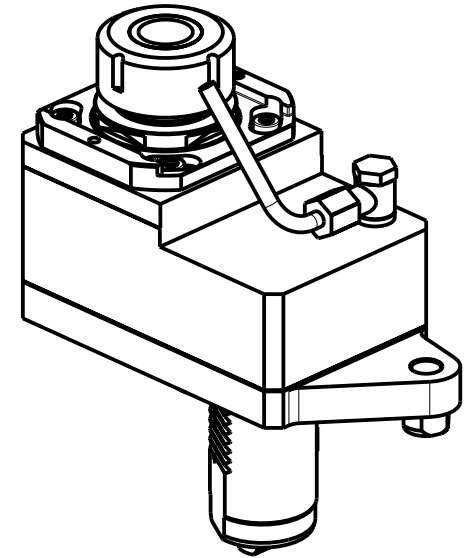
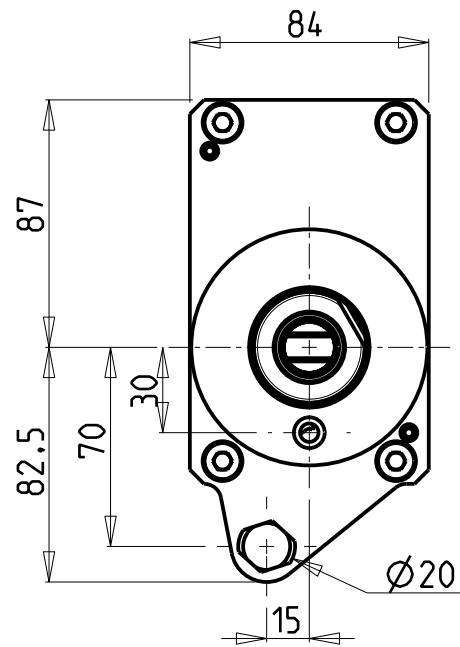
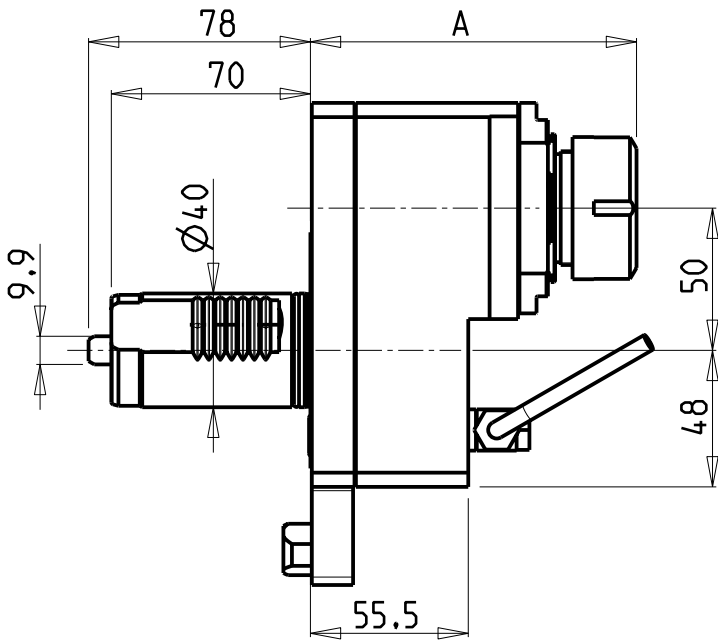

CUSCINETTI MAGGIORATI
PER LAVORAZIONI PESANTI

Reinforced bearings for
heavy machining

Vergroesserte Lager fuer
schwerere Bearbeitungen

- Chiave inclusa
- Key included
- Schluessel inbegriffen

Cod. MT	Mandrino Spindle Spindel	I	RPM	Coppia Max Max Torque Max Drehmoment	Lubrificazione est. Ext. coolant Aussenkuhlung	A	CHIAVI NON INCLUSE Keys not included Schluessel nicht einbegriffen	
MZK0242125	ER25	1:2	12000	40Nm	X	111.6	OKU0650004	CHSTER25
MZK0242132	ER32	1:2	12000	40Nm	X	114.6	OKU0650004	CHSTER32

MAZAK
SQT 15-18M/MS/MY/MSY 12 STAZIONI - SQT200-250M/MS/MY/MSY 12 STAZIONI - QT NEXUS 200-250M/MS/MY/MSY 12 STAZIONI
QT NEXUS 20011-25011 M/MS/MY/MSY 12 STAZIONI - SUPER QUADREX 200-250M - IVS200/300M

MODULO MOTORIZZATO RADIALE MAGGIORATO MOLTIPLICATO I=1:2 DISASSATO IN Z 50mm
Radial reinforced geared-up I=1:2 driven tool re-directed in Z by 50mm
Radial angetriebenes Werkzeug vergroessert uebersetzt I=1:2 achsversetzt in Z um 50mm

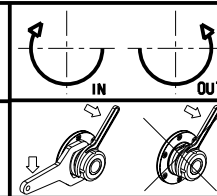

M.T. srl
Via Casino Albini 480
Tel. 0541/956034-957884
Fax 0541/956341
47842 S. GIOVANNI IN M. (RN)
e-mail: mtma@mtmarchetti.com
http://www.mtmarchetti.com



PAGINA MZK031-1-30

Subject to change without notice.

09/2022

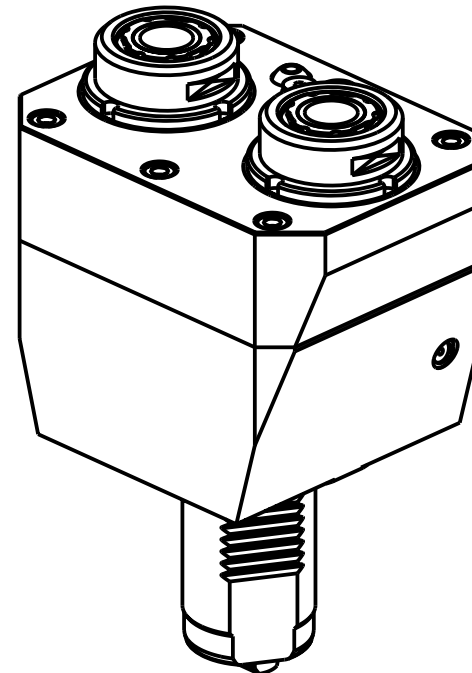
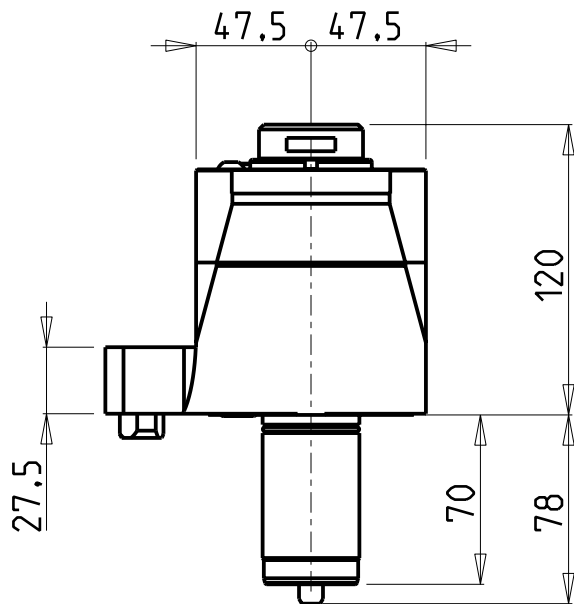
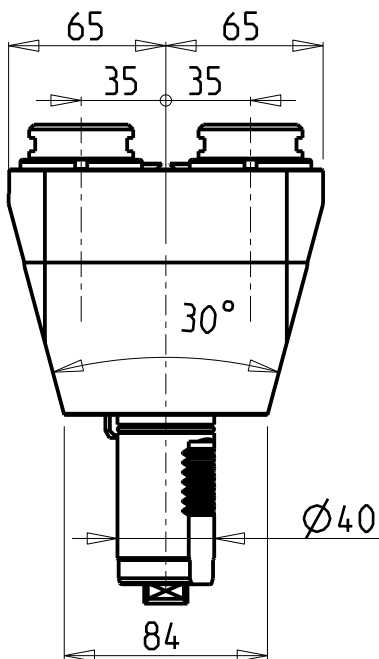
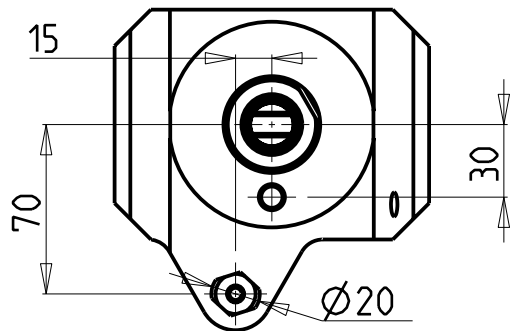

- Chiave inclusa
- Key included
- Schluessel inbegriffen

Cod. MT	Mandrino Spindle Spindel	I	RPM	Coppia Max Max Torque Max Drehmoment	Lubrificazione est. Ext. coolant Aussenkuehlung	CHIAVI NON INCLUSE Keys not included Schluessel nicht einbegriffen		
MZK0931225	ERA25	1:1	6000	50Nm	X	CHUB27	CHTAER25ZC	CHUB38

MAZAK
 SQT 15-18M/MS/MY/MSY 12 STAZIONI - SQT200-250M/MS/MY/MSY 12 STAZIONI - QT NEXUS 200-250M/MS/MY/MSY 12 STAZIONI
 QT NEXUS 20011-25011 M/MS/MY/MSY 12 STAZIONI

MODULO MOTORIZZATO RADIALE 2 USCITE IN Y
 Radial single side twin head driven tool in Y
 Radial angetriebenes Werkzeug 2 Ausgaenge in Y

Subject to change without notice.

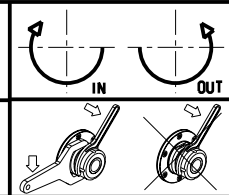

M.T. srl
 Via Casino Albini 480
 Tel. 0541/956034-957884
 Fax 0541/956341
 47842 S. GIOVANNI IN M. (RN)
 e-mail: mtma@mtmarchetti.com
 http://www.mtmarchetti.com



PAGINA MZK080-1-00

ATTENZIONE - ATTENTION - ACHTUNG

- Per lo smontaggio degli utensili utilizzare sempre la chiave di contrasto come indicato nel manuale d'uso.
- For disassembly of the tools use always the contrast key as mentioned in the user instructions.
- Fuer das Abmontieren der Werkzeuge immer den Gegenschlüssel benutzen wie in der Bedienungsanleitung erwaeht.

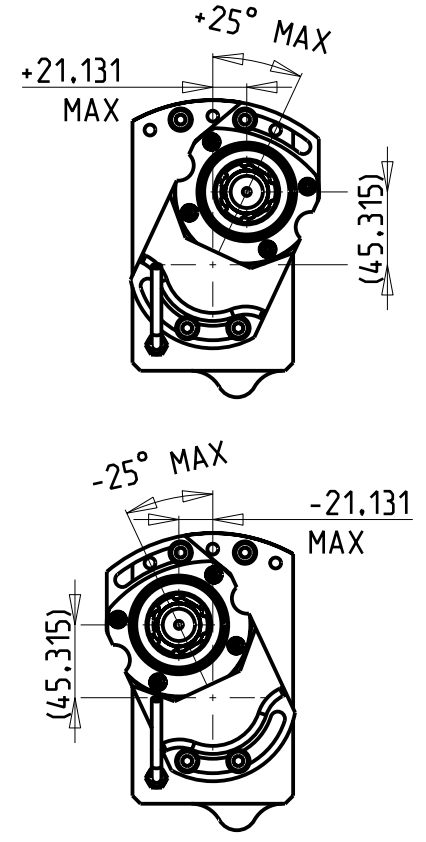
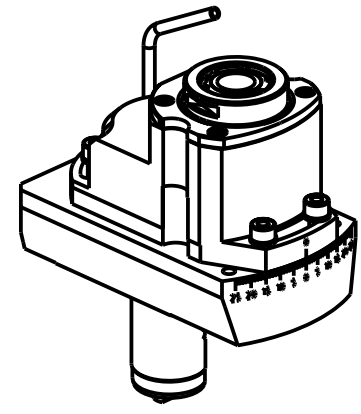
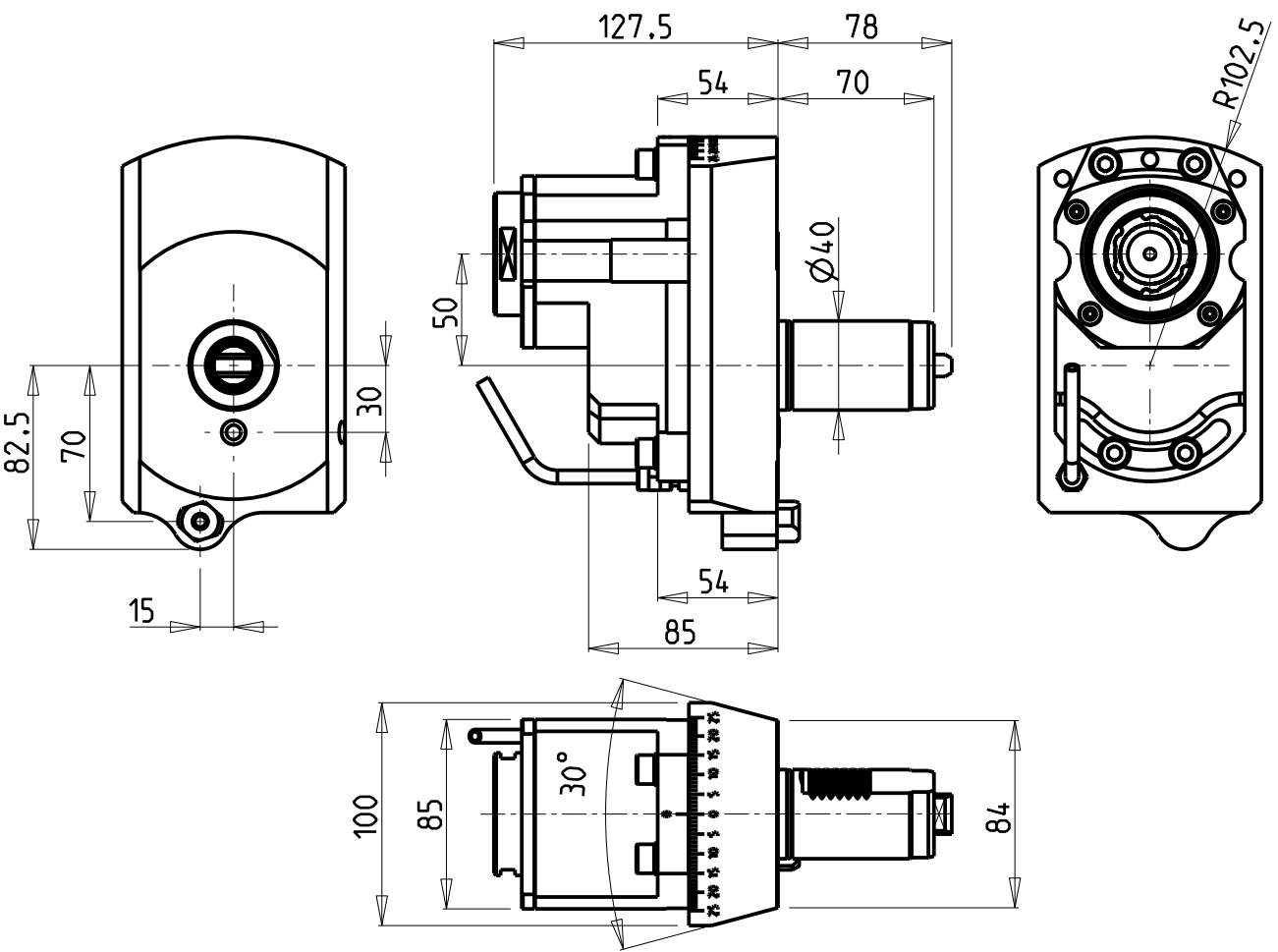

- Chiave inclusa
- Key included
- Schluessel inbegriffen

Cod. MT	Mandrino Spindel Spindel	I	RPM	Coppia Max Max Torque Max Drehmoment	Lubrificazione est. Ext. coolant Aussenkuehlung	CHIAVI NON INCLUSE Keys not included Schluessel nicht einbegriffen		
MZK0660332	ERA32	1:1	6000	80Nm	X	CHUB30	CHUB50	CHTAER32ZC *

MAZAK
 SQT 15-18M/MS/MY/MSY 12 STAZIONI - SQT200-250M/MS/MY/MSY 12 STAZIONI - QT NEXUS 200-250M/MS/MY/MSY 12 STAZIONI
 QT NEXUS 20011-25011 M/MS/MY/MSY 12 STAZIONI - SUPER QUADREX 200-250M - IVS200/300M

MODULO MOTORIZZATO RADIALE DISASSATO 50mm ORIENTABILE ±25°
 Radial ±25° adjustable angle driven tool re-directed by 50mm
 Radial angetriebenes Werkzeug schwenkbar ±25° achsversetzt um 50mm

Subject to change without notice.

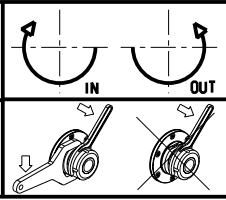

M.T. srl
 Via Casino Albini 480
 Tel. 0541/956034-957884
 Fax 0541/956341
 47842 S. GIOVANNI IN M. (RN)
 e-mail: mtma@mtmarchetti.com
 http://www.mtmarchetti.com



PAGINA MZK135-1-00

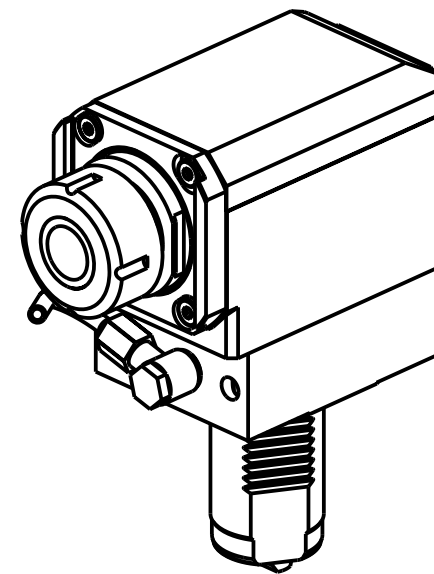
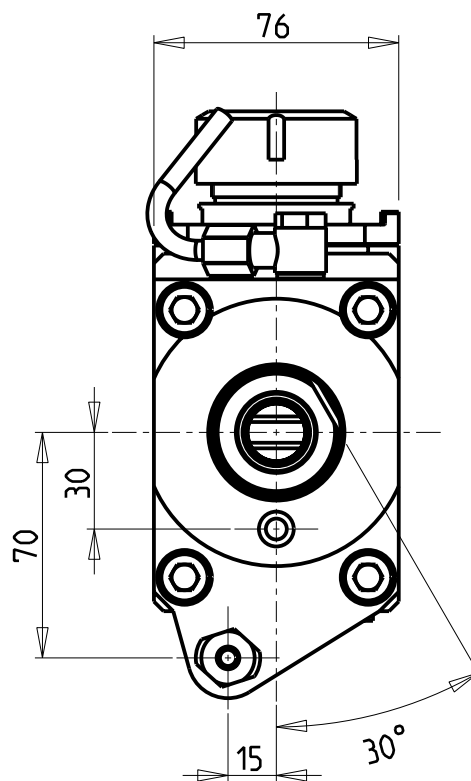
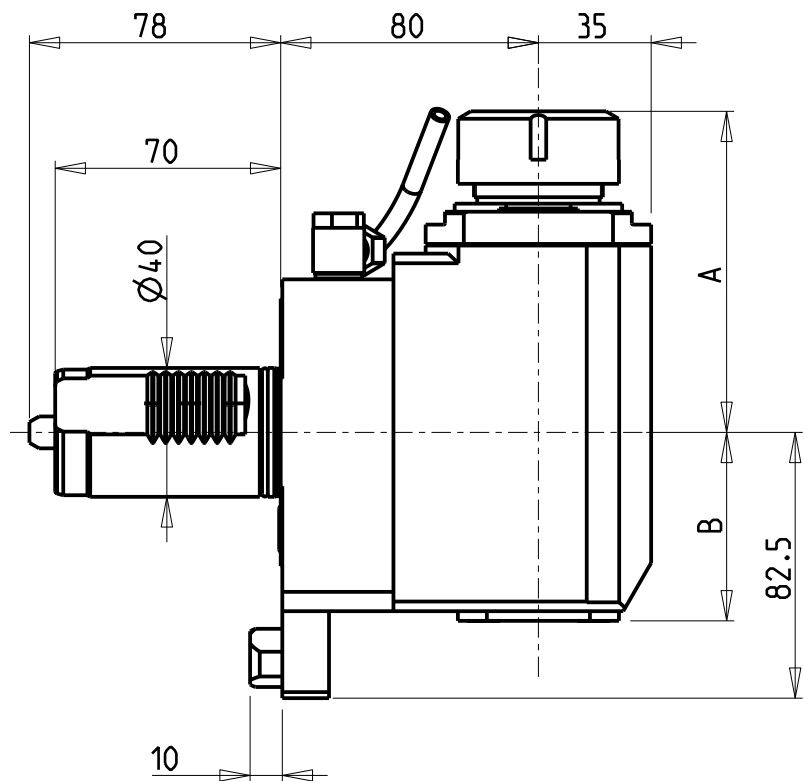

Cod. MT	Mandrino Spindle Spindel	I	RPM	Coppia Max Max Torque Max Drehmoment	Lubrificazione int. Coolant through Innenkuehlung	Lubrificazione est. Ext. coolant Ausenkuehlung	A	B	CHIAVI NON INCLUSE Keys not included Schluessel nicht einbegriffen	
MZK0021132	ER32	1:1	6000	70Nm	-	X	99.7	58.5	OKU0650004 •	CHSTER32
MZK0021232	ER32	1:1	6000	70Nm	P=70bar	X	99.7	69.5	OKU0650004 •	CHSTER32
MZK0021140	ER40	1:1	6000	70Nm	-	X	103.7	58.5	OKU0650004 •	CHSTER40
MZK0021240	ER40	1:1	6000	70Nm	P=70bar	X	103.7	69.5	OKU0650004 •	CHSTER40

- Chiave inclusa
- Key included
- Schluessel inbegriffen

MAZAK
 SQT 15-18M/MS/MY/MSY 12 STAZIONI - SQT200-250M/MS/MY/MSY 12 STAZIONI - QT NEXUS 200-250M/MS/MY/MSY 12 STAZIONI
 QT NEXUS 20011-25011 M/MS/MY/MSY 12 STAZIONI - SUPER QUADREX 200-250M

MODULO MOTORIZZATO ASSIALE H=80mm
 Axial driven tool H=80mm
 Axial angetriebenes Werkzeug H=80mm

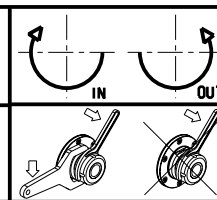

M.T. srl
 Via Casino Albini 480
 Tel. 0541/956034-957884
 Fax 0541/956341
 47842 S. GIOVANNI IN M. (RN)
 e-mail: mtma@mtmarchetti.com
 http://www.mtmarchetti.com



PAGINA MZK150-1-10

Subject to change without notice.

09/2022

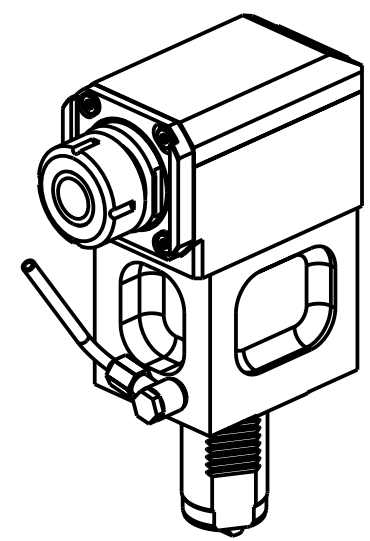
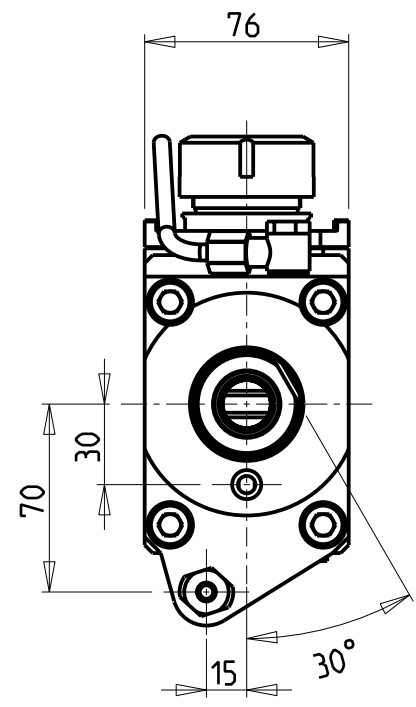
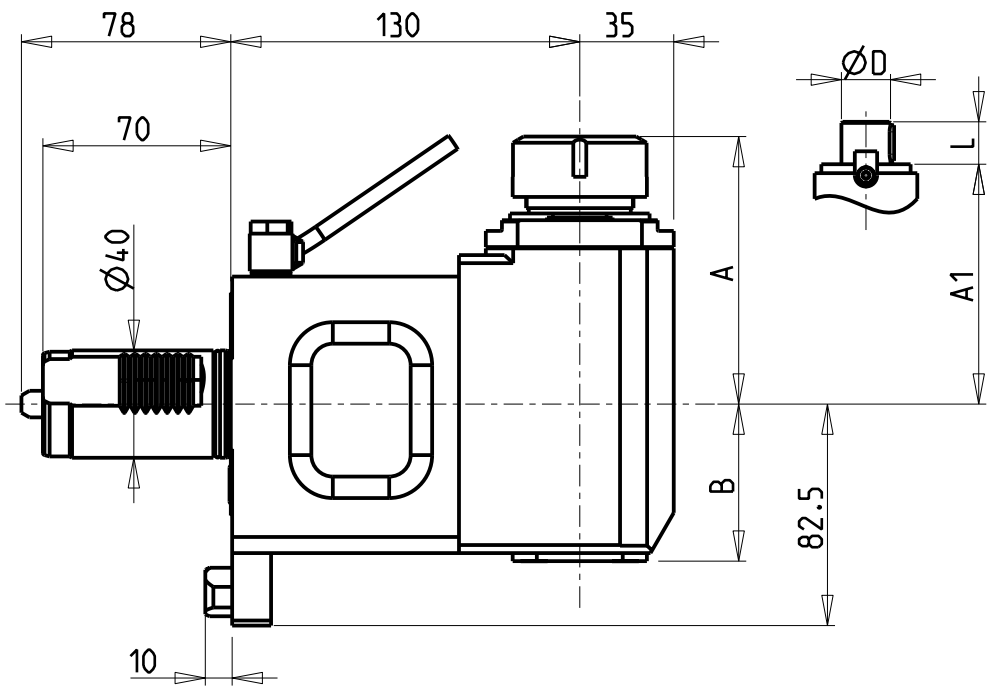

Cod. MT	Mandrino Spindel	I	RPM	Coppia Max Max Torque Max Drehmoment	Lubrificazione int. Coolant through Innenkuehlung	Lubrificazione est. Ext. coolant Aussenkuehlung	A	B	A1	D	L	CHIAVI NON INCLUDE Keys not included Schlüssel nicht einbegriffen	
MZK0020132	ER32	1:1	6000	70Nm	-	X	99.7	58.5	-	-	-	OKU0650004	CHSTER32
MZK0021032	ER32	1:1	6000	70Nm	P=70bar	X	99.7	69.5	-	-	-	OKU0650004	CHSTER32
MZK0020140	ER40	1:1	6000	70Nm	-	X	103.7	58.5	-	-	-	OKU0650004	CHSTER40
MZK0020240	ER40	1:1	6000	70Nm	P=70bar	X	103.7	69.5	-	-	-	OKU0650004	CHSTER40
MZK0020027	Ø27x21	1:1	6000	70Nm	-	X	-	58.5	78.5	27	21	CHUB41	CH_VTCROCE_M12
MZK0020022	Ø22x19	1:1	6000	70Nm	-	X	-	58.5	78.5	22	19	CHUB41	CH_VTCROCE_M10

- Chiave inclusa
- Key included
- Schlüssel inbegriffen

MAZAK
 SQT 15-18M/MS/MY/MSY 12 STAZIONI - SQT200-250M/MS/MY/MSY 12 STAZIONI - QT NEXUS 200-250M/MS/MY/MSY 12 STAZIONI
 QT NEXUS 20011-25011 M/MS/MY/MSY 12 STAZIONI - SUPER QUADREX 200-250M - IVS200/300M

MODULO MOTORIZZATO ASSIALE H=130mm
 Axial driven tool H=130mm
 Axial angetriebenes Werkzeug H=130mm

Subject to change without notice.

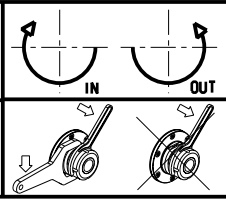

M.T. srl
 Via Casino Albini 480
 Tel. 0541/956034-957884
 Fax 0541/956341
 47842 S. GIOVANNI IN M. (RN)
 e-mail: mtma@mtmarchetti.com
 http://www.mtmarchetti.com



PAGINA MZK150-1-20

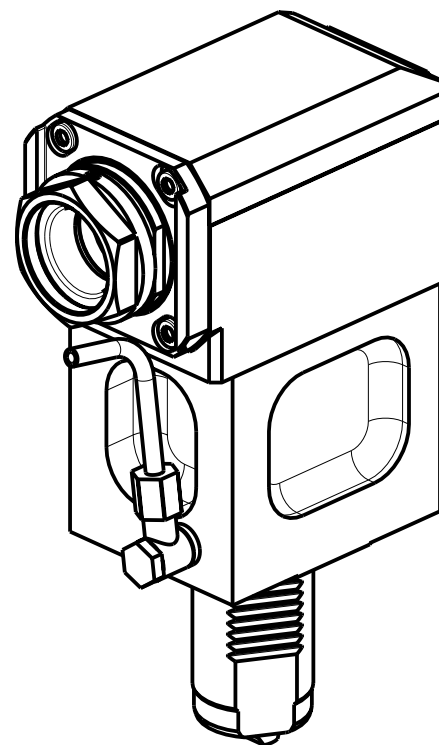
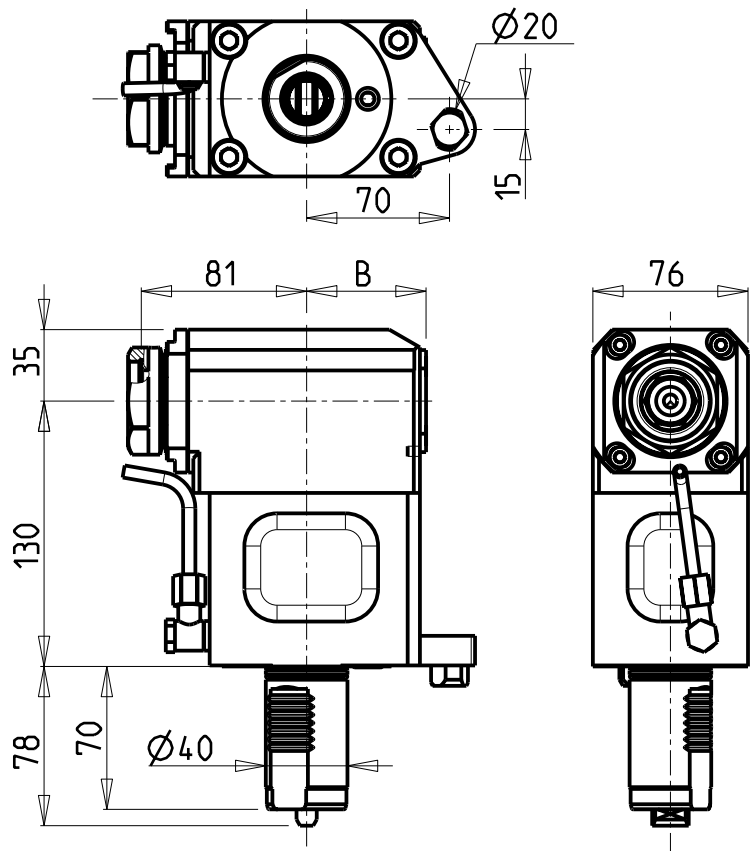

ATTENZIONE - ATTENTION - ACHTUNG

- Per lo smontaggio degli utensili utilizzare sempre la chiave di contrasto come indicato nel manuale d'uso.
- For disassembly of the tools use always the contrast key as mentioned in the user instructions.
- Fuer das Abmontieren der Werkzeuge immer den Gegenschlüssel benutzen wie in der Bedienungsanleitung erwaeht.

- Chiave inclusa
- Key included
- Schlüssel inbegriffen

PER PORTAUTENSILI MODULARI MTSK-40 VEDI PAG. TBL300-1-40
 FOR MTSK-40 QUICK CHANGE TOOLHOLDERS CLAMPINGS SEE PAGE TBL300-1-40
 FUER MTSK-40 MODULARE WERKZEUGAUFNAHMEN SIEHE SEITE TBL300-1-40

Cod. MT	Mandrino Spindle Spindel	I	RPM	Coppia Max Max Torque Max Drehmoment	Lubrificazione int. Coolant through Innenkuehlung	Lubrificazione est. Ext. coolant Aussenkuehlung	B	CHIAVI NON INCLUSE Keys not included Schlüssel nicht einbegriffen	
MZK0280140	MTSK-40	1:1	6000	70Nm	-	X	58.5	CHUB46	OKU0650004
MZK0280240	MTSK-40	1:1	6000	70Nm	P=70bar	X	69.5	CHUB46	OKU0650004

MAZAK
 SQT 15-18M/MS/MY/MSY 12 STAZIONI - SQT200-250M/MS/MY/MSY 12 STAZIONI - QT NEXUS 200-250M/MS/MY/MSY 12 STAZIONI
 QT NEXUS 20011-25011 M/MS/MY/MSY 12 STAZIONI - SUPER QUADREX 200-250M - IVS200/300M

MODULO MOTORIZZATO ASSIALE MTSK
 Axial MTSK driven tool
 Axial MTSK angetriebenes Werkzeug

Subject to change without notice.

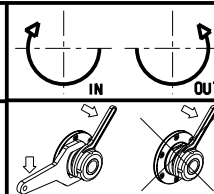

M.T. srl
 Via Casino Albini 480
 Tel. 0541/956034-957884
 Fax 0541/956341
 47842 S. GIOVANNI IN M. (RN)
 e-mail: mtma@mtmarchetti.com
 http://www.mtmarchetti.com



PAGINA MZK150-1-20-K

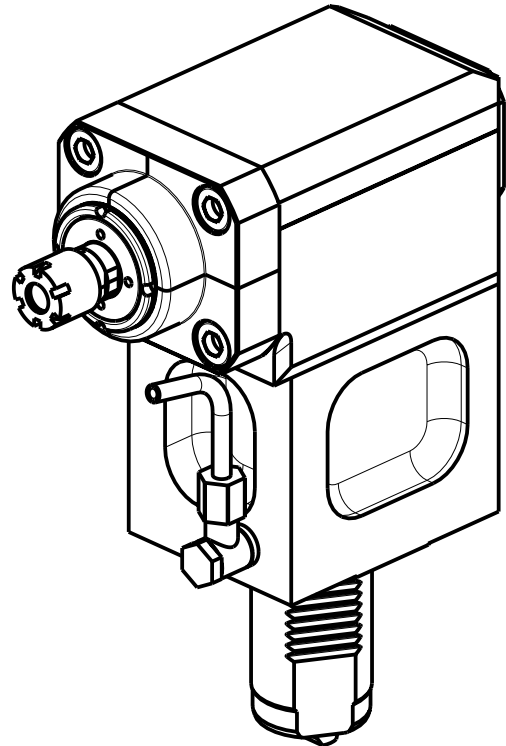
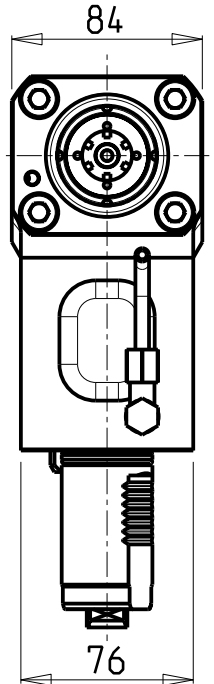
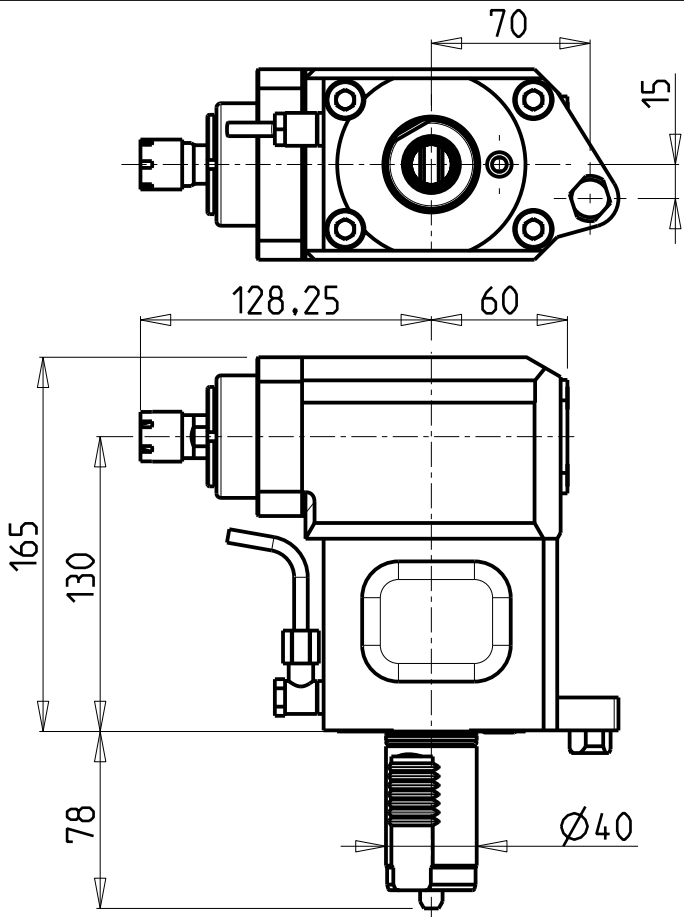

ATTENZIONE - ATTENTION - ACHTUNG

- Per lo smontaggio degli utensili utilizzare sempre la chiave di contrasto come indicato nel manuale d'uso.
- For disassembly of the tools use always the contrast key as mentioned in the user instructions.
- Fuer das Abmontieren der Werkzeuge immer den Gegenschlüssel benutzen wie in der Bedienungsanleitung erwaeht.

ATTENZIONE - ATTENTION - ACHTUNG

- PRIMA DI UTILIZZARE IL MOTORIZZATO CONSULTARE LE ISTRUZIONI ALLEGATE!
- BEFORE USING THE DRIVEN TOOL, PLEASE CHECK THE ENCLOSED INSTRUCTION SHEET!
- VOR DER BENUTZUNG DES ANGETRIEBENEN WERKZEUGES, DIE BEILIEGENDEN INSTRUKTIONEN DURCHLESEN!

Cod. MT	Mandrino Spindle Spindel	I	RPM	Coppia Max Max Torque Max Drehmoment	Lubrificazione est. Ext. coolant Aussenkuehlung	CHIAVI INCLUDE Keys included Schluessel einbegriffen	
MZK0390016	ER16	1:3	18000	10Nm	X	CHUB17	CHMNER16

MAZAK
 SQT 15-18M/MS/MY/MSY 12 STAZIONI - SQT200-250M/MS/MY/MSY 12 STAZIONI - QT NEXUS 200-250M/MS/MY/MSY 12 STAZIONI
 QT NEXUS 200II-250II M/MS/MY/MSY 12 STAZIONI - SUPER QUADREX 200-250M - IVS200/300M

MODULO MOTORIZZATO ASSIALE MOLTIPLICATO I=1:3
 Axial geared-up I=1:3 driven tool
 Axial angetriebenes Werkzeug uebersetzt I=1:3

Subject to change without notice.

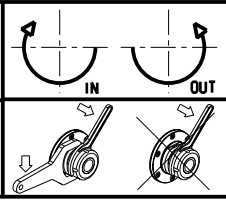

M.T. srl
 Via Casino Albini 480
 Tel. 0541/956034-957884
 Fax 0541/956341
 47842 S. GIOVANNI IN M. (RN)
 e-mail: mtma@mtmarchetti.com
 http://www.mtmarchetti.com



PAGINA MZK208-1-10

ATTENZIONE - ATTENTION - ACHTUNG

- Per lo smontaggio degli utensili utilizzare sempre la chiave di contrasto come indicato nel manuale d'uso.
- For disassembly of the tools use always the contrast key as mentioned in the user instructions.
- Fuer das Abmontieren der Werkzeuge immer den Gegenschlüssel benutzen wie in der Bedienungsanleitung erwäehnt.

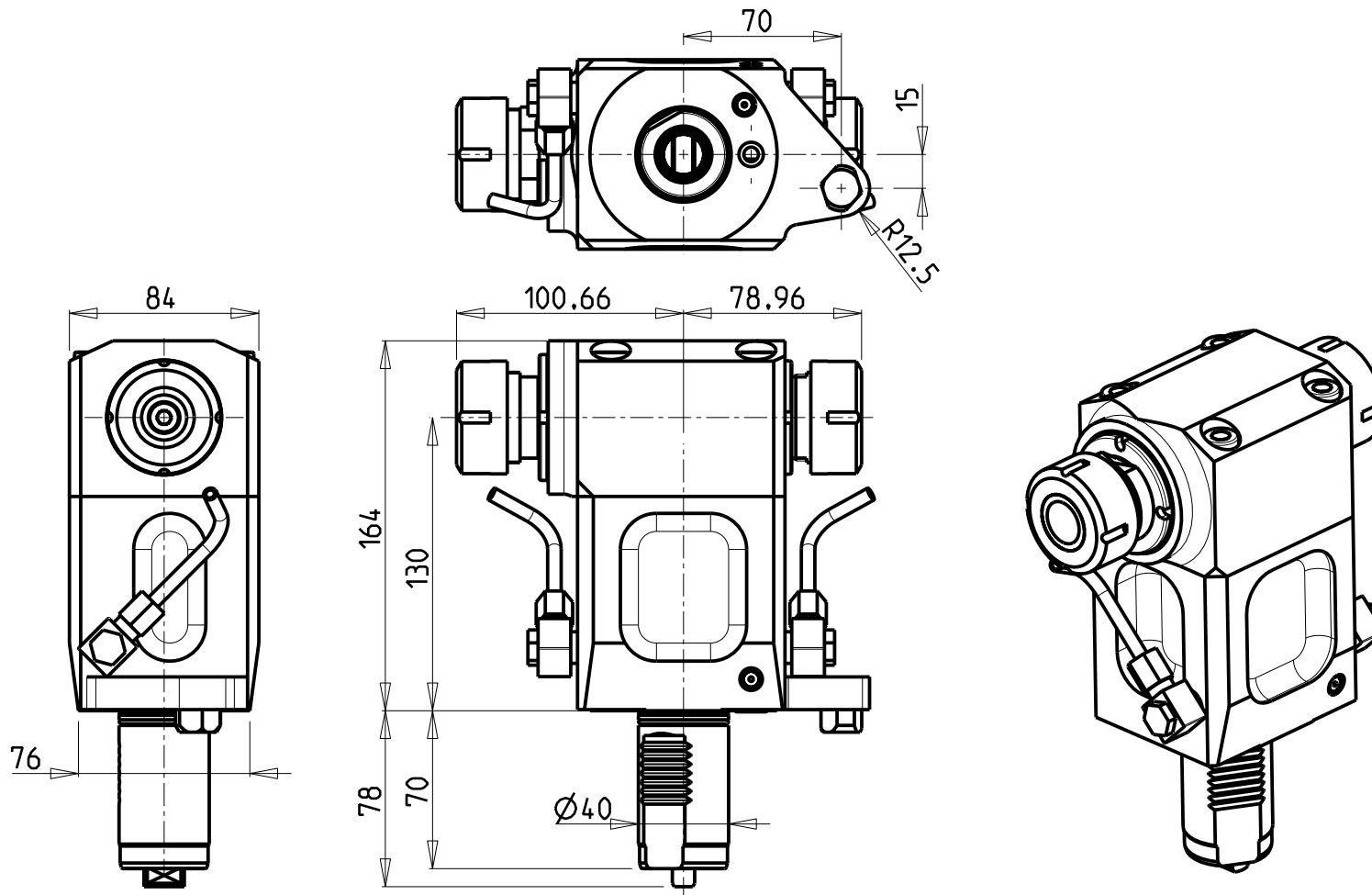

Cod. MT	Mandrino Spindle Spindel	I	RPM	Coppia Max Max Torque Max Drehmoment	Lubrificazione est. Ext. coolant Ausseukuehlung	CHIAVI NON INCLUSE Keys not included Schluesssel nicht einbegriffen	
MZK0160232	ER32+ER32	1:1	6000	70Nm	X	CHUB36	CHSTER32

MAZAK
 SQT 15-18M/MS/MY/MSY 12 STAZIONI - SQT200-250M/MS/MY/MSY 12 STAZIONI - QT NEXUS 200-250M/MS/MY/MSY 12 STAZIONI
 QT NEXUS 20011-25011 M/MS/MY/MSY 12 STAZIONI - SUPER QUADREX 200-250M

MODULO MOTORIZZATO ASSIALE BISPORGENTE
 Axial opposite face twin driven tool
 Axial angetriebenes Werkzeug halb vorspringend

Subject to change without notice.

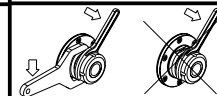

M.T. srl
 Via Casino Albini 480
 Tel. 0541/956034-957884
 Fax 0541/956341
 47842 S. GIOVANNI IN M. (RN)
 e-mail: mtma@mtmarchetti.com
 http://www.mtmarchetti.com



PAGINA MZK240-1-10

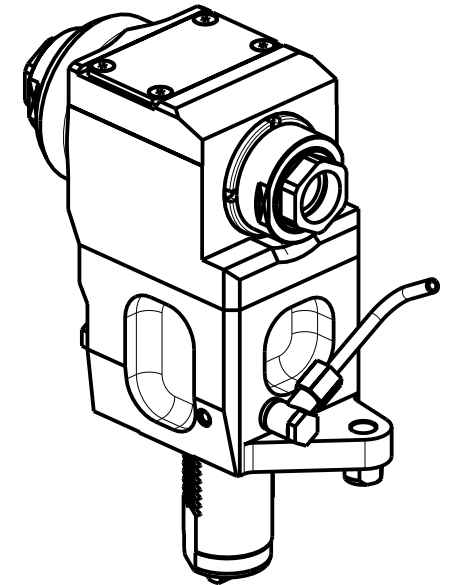
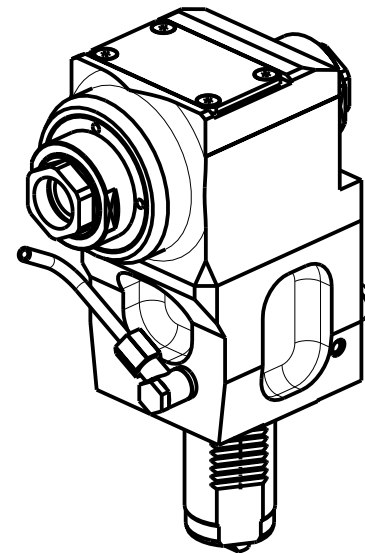
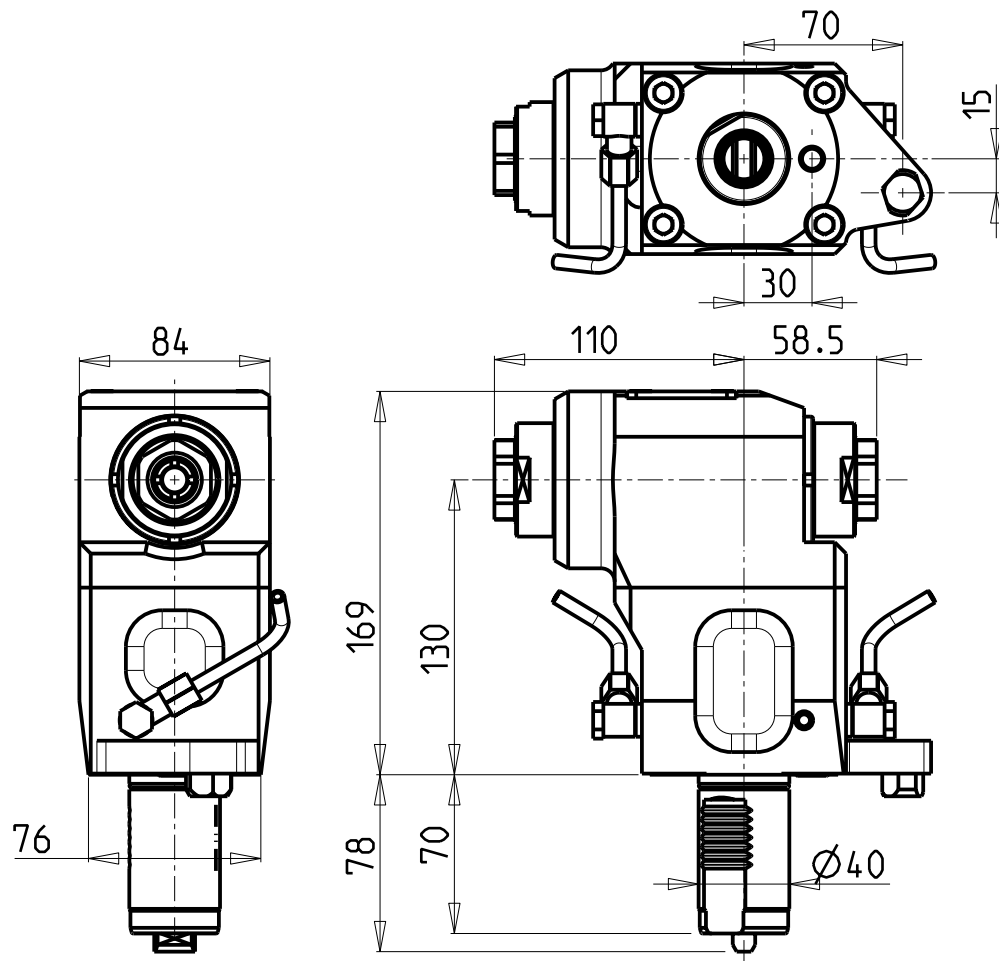

ATTENZIONE - ATTENTION - ACHTUNG

- Per lo smontaggio degli utensili utilizzare sempre la chiave di contrasto come indicato nel manuale d'uso.
- For disassembly of the tools use always the contrast key as mentioned in the user instructions.
- Fuer das Abmontieren der Werkzeuge immer den Gegenschlüssel benutzen wie in der Bedienungsanleitung erwäehnt.

Cod. MT	Mandrino Spindle Spindel	I	RPM	Coppia Max Max Torque Max Drehmoment	Lubrificazione est. Ext. coolant Aussenkuehlung	CHIAVI NON INCLUSE Keys not included Schlüssel nicht inbegriffen	
MZK0210232	ERA32+ERA32	1:1	6000	70Nm	X	CHUB32	CHUB46

MAZAK
 SQT 15-18M/MS/MY/MSY 12 STAZIONI - SQT200-250M/MS/MY/MSY 12 STAZIONI - QT NEXUS 200-250M/MS/MY/MSY 12 STAZIONI
 QT NEXUS 200II-250II M/MS/MY/MSY 12 STAZIONI - SUPER QUADREX 200-250M

MODULO MOTORIZZATO ASSIALE ARRETRATO BISPORGENTE
 Axial opposite face rear-set driven tool
 Axial angetriebenes Werkzeug zurueckversetzt halb vorspringend

Subject to change without notice.

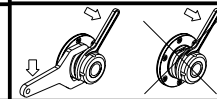

M.T. srl
 Via Casino Albini 480
 Tel. 0541/956034-957884
 Fax 0541/956341
 47842 S. GIOVANNI IN M. (RN)
 e-mail: mtma@mtmarchetti.com
 http://www.mtmarchetti.com



PAGINA MZK243-1-10

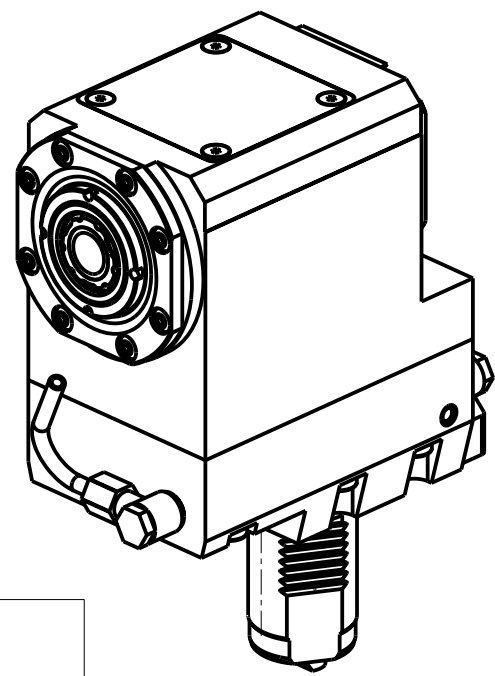
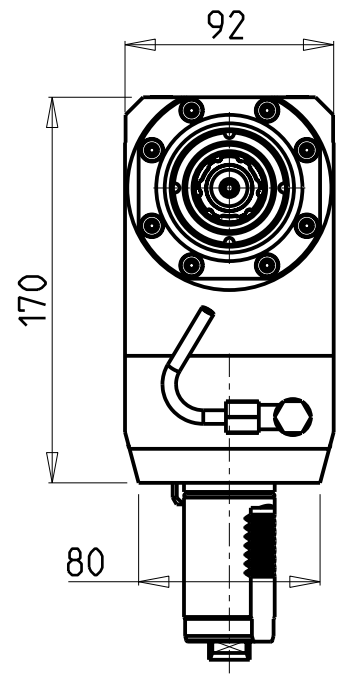
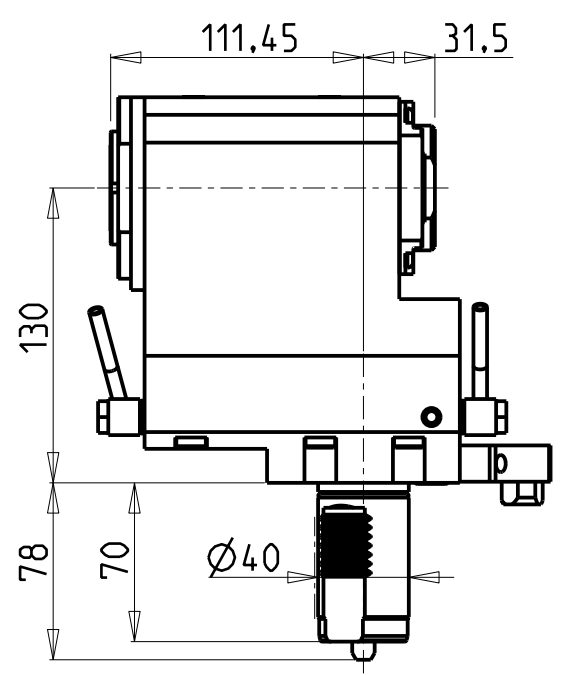
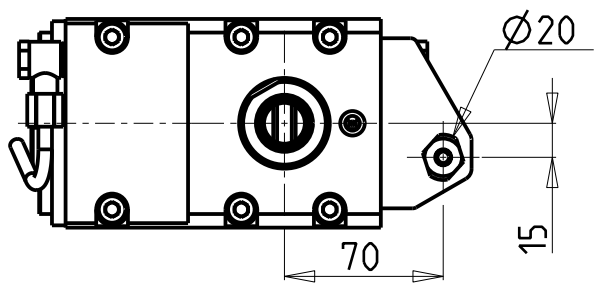

ATTENZIONE - ATTENTION - ACHTUNG

- Per lo smontaggio degli utensili utilizzare sempre la chiave di contrasto come indicato nel manuale d'uso.
- For disassembly of the tools use always the contrast key as mentioned in the user instructions.
- Fuer das Abmontieren der Werkzeuge immer den Gegenschlüssel benutzen wie in der Bedienungsanleitung erwaeht.

Cod. MT	Mandrino Spindle Spindel	I	RPM	Coppia Max Max Torque Max Drehmoment	Lubr.esterna Ext. coolant Aussenkuehlung	CHIAVI NON INCLUSE Keys not included Schlüssel nicht einbegriffen		
MZK1050225	ERA25+ERA25	1:2	12000	50Nm	X	CHUB27	OKU0650004 *	CHTAER25ZC *

- Chiave inclusa
- Key included
- Schlüssel inbegriffen

MAZAK
 SQT 15-18M/MS/MY/MSY 12 STAZIONI - SQT200-250M/MS/MY/MSY 12 STAZIONI - QT NEXUS 200-250M/MS/MY/MSY 12 STAZIONI
 QT NEXUS 20011-25011 M/MS/MY/MSY 12 STAZIONI - SUPER QUADREX 200-250M

MODULO MOTORIZZATO ASSIALE BISPORGENTE MOLTIPLICATO I=1:2
 Axial geared-up I=1:2 opposite face twin driven tool
 Axial angetriebenes Werkzeug halb vorspringend uebersetzt I=1:2

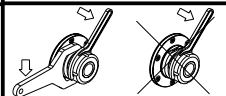

M.T. srl
 Via Casino Albini 480
 Tel. 0541/956034-957884
 Fax 0541/956341
 47842 S. GIOVANNI IN M. (RN)
 e-mail: mtma@mtmarchetti.com
 http://www.mtmarchetti.com



PAGINA MZK250-1-00

Subject to change without notice.

09/2022

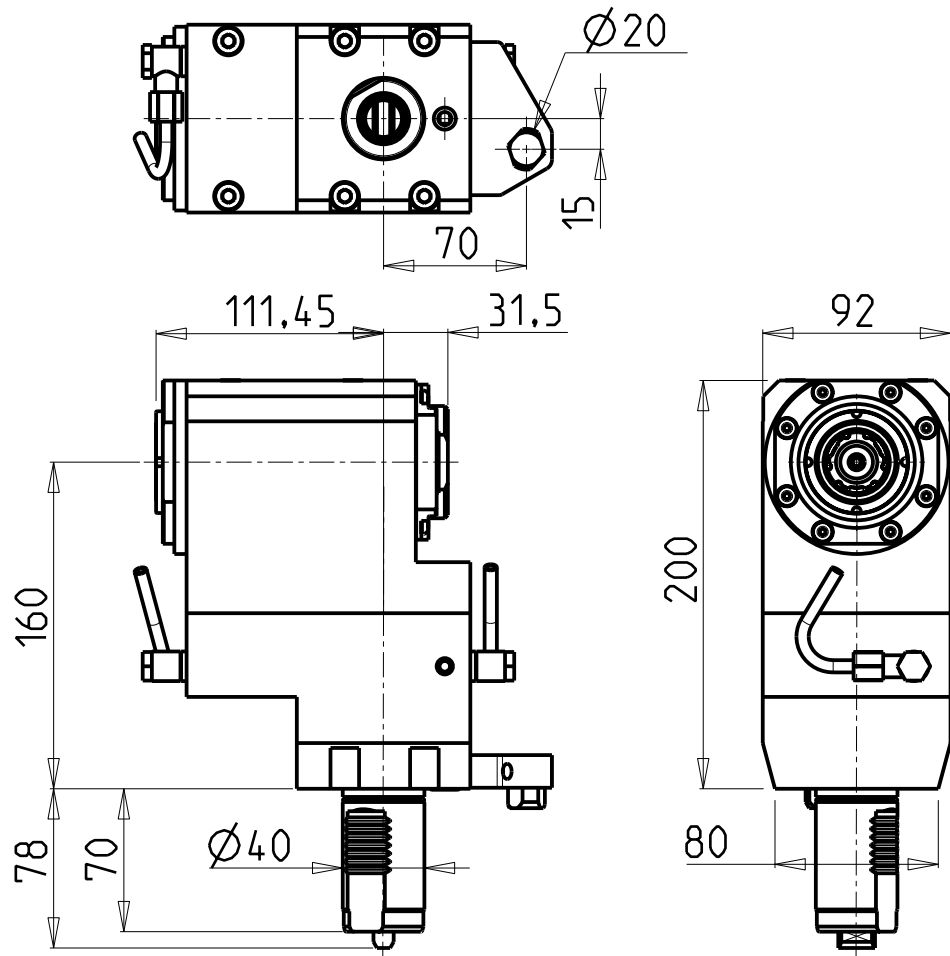

ATTENZIONE - ATTENTION - ACHTUNG

- VERIFICARE LE MISURE DI INGOMBRO PER POSSIBILE INTERFERENZA SU ALCUNI MODELLI DI MACCHINE
- Please check the overall sizes for possible interferences on some machine models
- Bitte überprüfen sie das ausmass um mögliche interferenzen auf einigen maschinen modellen zu vermeiden

ATTENZIONE - ATTENTION - ACHTUNG

- Per lo smontaggio degli utensili utilizzare sempre la chiave di contrasto come indicato nel manuale d'uso.
- For disassembly of the tools use always the contrast key as mentioned in the user instructions.
- Fuer das Abmontieren der Werkzeuge immer den Gegenschlüssel benutzen wie in der Bedienungsanleitung erwaehtnt.

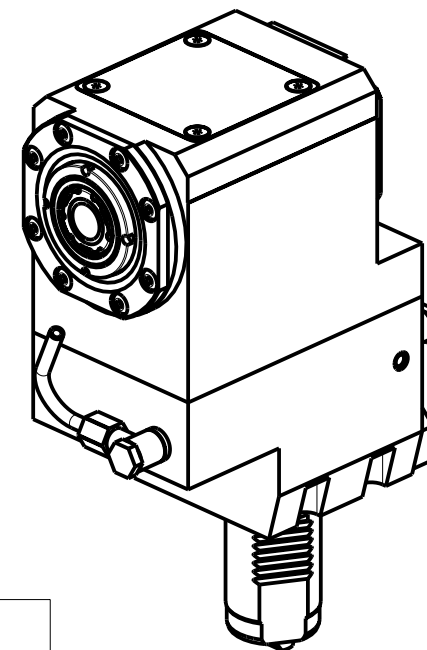

- Chiave inclusa
- Key included
- Schlüssel inbegriffen

Cod. MT	Mandrino Spindle Spindel	I	RPM	Coppia Max Max Torque Max Drehmoment	Lubr.esterna Ext. coolant Aussenkuehlung	CHIAVI NON INCLUSE Keys not included Schlüssel nicht einbegriffen		
MZK0470225	ERA25+ERA25	1:2	12000	50Nm	X	CHUB27	OKU0650004 *	CHTAER25ZC *

MAZAK
 SQT 15-18M/MS/MY/MSY 12 STAZIONI - SQT200-250M/MS/MY/MSY 12 STAZIONI - QT NEXUS 200-250M/MS/MY/MSY 12 STAZIONI
 QT NEXUS 20011-25011 M/MS/MY/MSY 12 STAZIONI - SUPER QUADREX 200-250M

MODULO MOTORIZZATO ASSIALE BISPORGENTE MOLTIPLICATO I=1:2
 Axial geared-up I=1:2 opposite face twin driven tool
 Axial angetriebenes Werkzeug halb vorspringend uebersetzt I=1:2

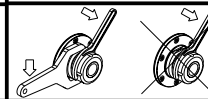

M.T. srl
 Via Casino Albini 480
 Tel. 0541/956034-957884
 Fax 0541/956341
 47842 S. GIOVANNI IN M. (RN)
 e-mail: mtma@mtmarchetti.com
 http://www.mtmarchetti.com



PAGINA MZK250-1-10

Subject to change without notice.

09/2022

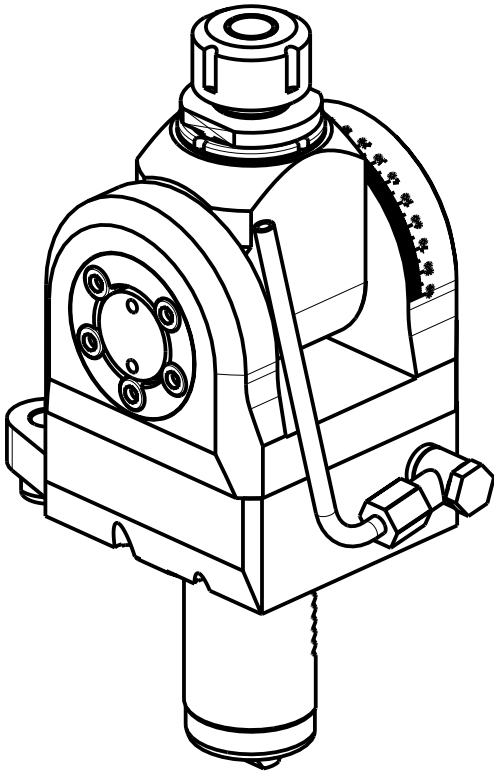
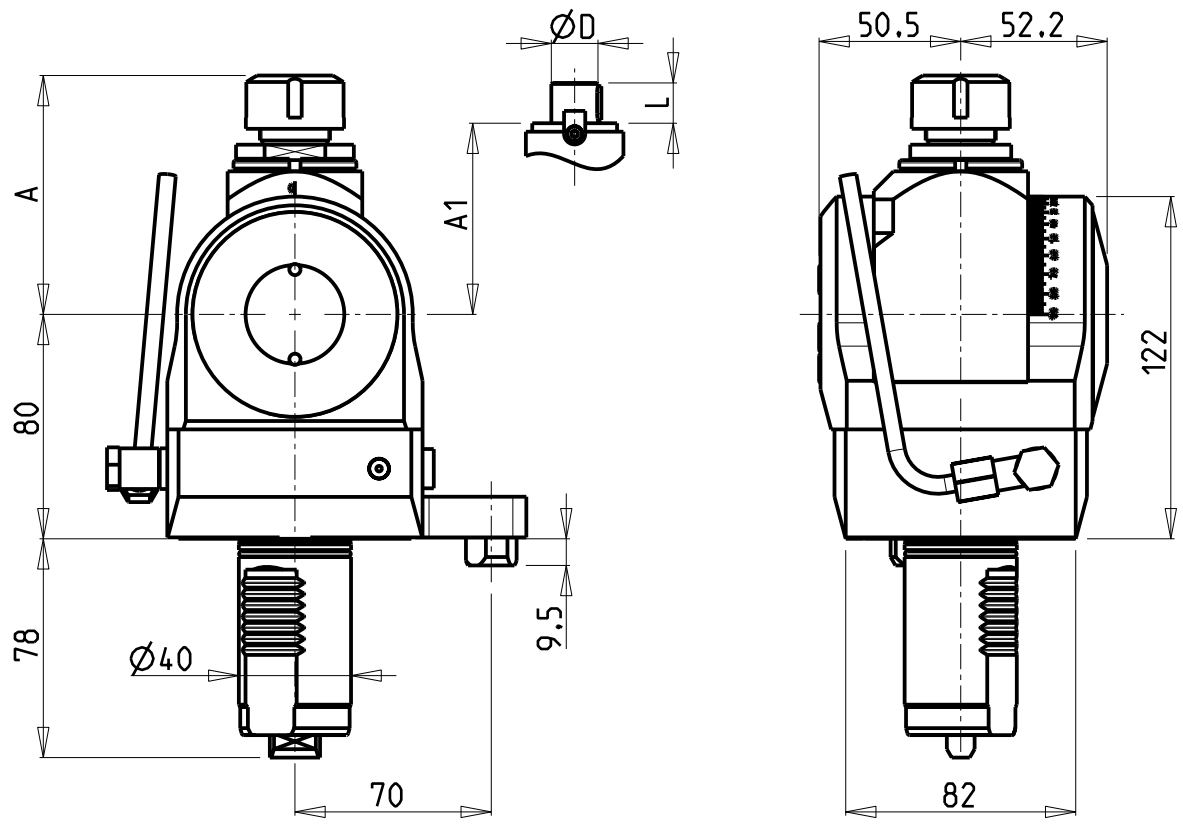

Cod. MT	Mandrino Spindle Spindel	I	RPM	Coppia Max Max Torque Max Drehmoment	Lubrificazione est. Ext. coolant Aussenkühlung	A	A1	D	L	CHIAVI INCLUSE Keys included Schluessel inbegriffen
MZK0580120	ER20	1:1	6000	40Nm	X	85.16	-	-	-	CHUB36 CHSTER20
MZK0580125	ER25	1:1	6000	40Nm	X	86.16	-	-	-	CHUB36 CHSTER25
MZK0580516	Ø16x17	1:1	6000	40Nm	X	-	65	16	17	CHUB36 CH_VTCROCE_M08
MZK0580522	Ø22x19	1:1	6000	40Nm	X	-	66	22	19	CHUB36 CH_VTCROCE_M10
MZK0580519	Ø3/4"x3/4"	1:1	6000	40Nm	X	-	65	3/4"	3/4"	CHUB36 CH_VTCROCE_M08

MAZAK
 SQT 15-18M/MS/MY/MSY 12 STAZIONI - SQT200-250M/MS/MY/MSY 12 STAZIONI - QT NEXUS 200-250M/MS/MY/MSY 12 STAZIONI
 QT NEXUS 20011-25011 M/MS/MY/MSY 12 STAZIONI - SUPER QUADREX 200-250M - IVS200/300M

MODULO MOTORIZZATO ORIENTABILE ±90°
 ±90° adjustable angle driven tool
 Angetriebenes Werkzeug schwenkbar ±90°

Subject to change without notice.

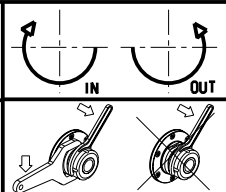

M.T. srl
 Via Casino Albini 480
 Tel. 0541/956034-957884
 Fax 0541/956341
 47842 S. GIOVANNI IN M. (RN)
 e-mail: mtma@mtmarchetti.com
 http://www.mtmarchetti.com



PAGINA MZK333-1-00

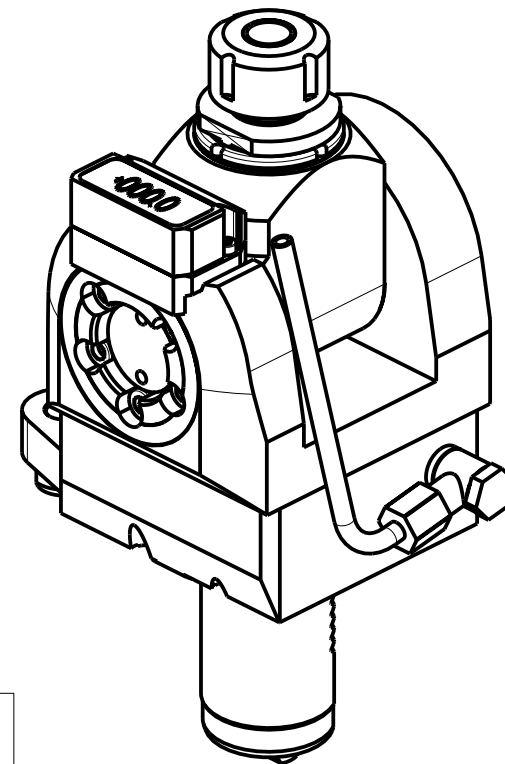
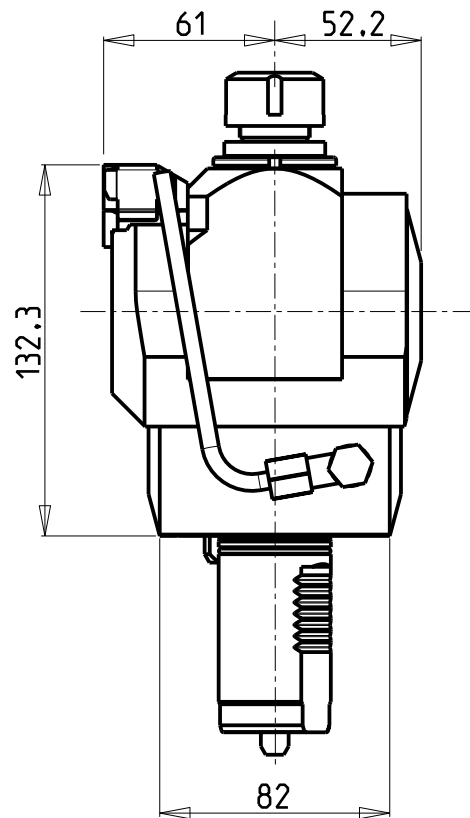
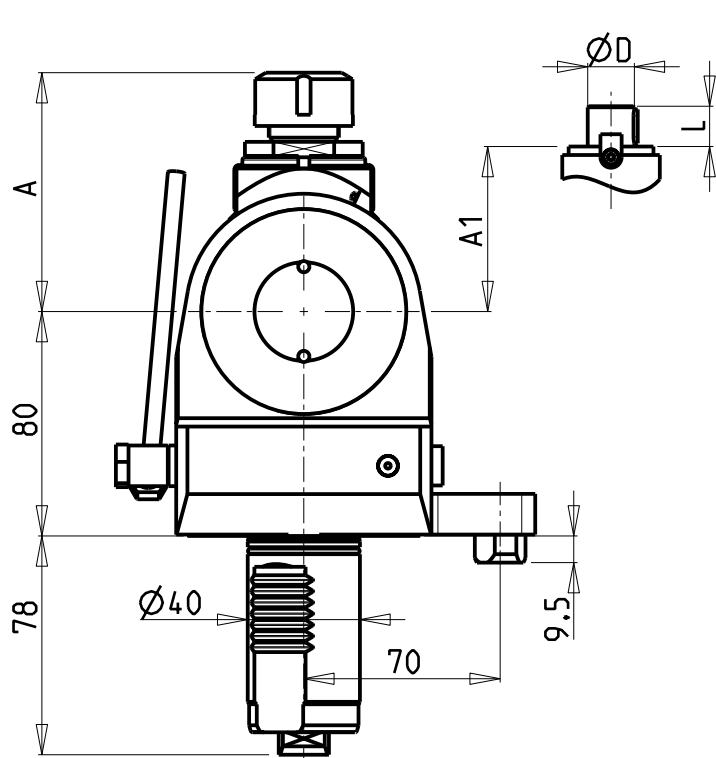

Cod. MT	Mandrino Spindle Spindel	I	RPM	Coppia Max Max Torque Max Drehmoment	Lubrificazione est. Ext. coolant Aussenkühlung	A	A1	D	L	CHIAVI INCLUSE Keys included Schlüssel inbegriffen	
MZK0530120	ER20	1:1	6000	40Nm	X	85.16	-	-	-	CHUB36	CHSTER20
MZK0530125	ER25	1:1	6000	40Nm	X	86.16	-	-	-	CHUB36	CHSTER25
MZK0530516	Ø16x17	1:1	6000	40Nm	X	-	65	16	17	CHUB36	CH_VTCROCE_M08
MZK0530522	Ø22x19	1:1	6000	40Nm	X	-	66	22	19	CHUB36	CH_VTCROCE_M10
MZK0530519	Ø3/4"x3/4"	1:1	6000	40Nm	X	-	65	3/4"	3/4"	CHUB36	CH_VTCROCE_M08

MAZAK
 SQT 15-18M/MS/MY/MSY 12 STAZIONI - SQT200-250M/MS/MY/MSY 12 STAZIONI - QT NEXUS 200-250M/MS/MY/MSY 12 STAZIONI
 QT NEXUS 20011-25011 M/MS/MY/MSY 12 STAZIONI - SUPER QUADREX 200-250M - IVS200/300M

MODULO MOTORIZZATO ORIENTABILE ±90° CON NONIO DIGITALE
 ±90° adjustable angle driven tool with digital display
 Angetriebenes Werkzeug schwenkbar ±90° mit digital display

Subject to change without notice.

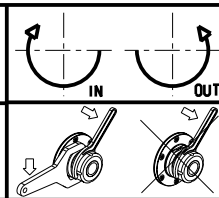

M.T. srl
 Via Casino Albini 480
 Tel. 0541/956034-957884
 Fax 0541/956341
 47842 S. GIOVANNI IN M. (RN)
 e-mail: mtma@tmarchetti.com
 http://www.mtmarchetti.com

PAGINA MZK333-1-01

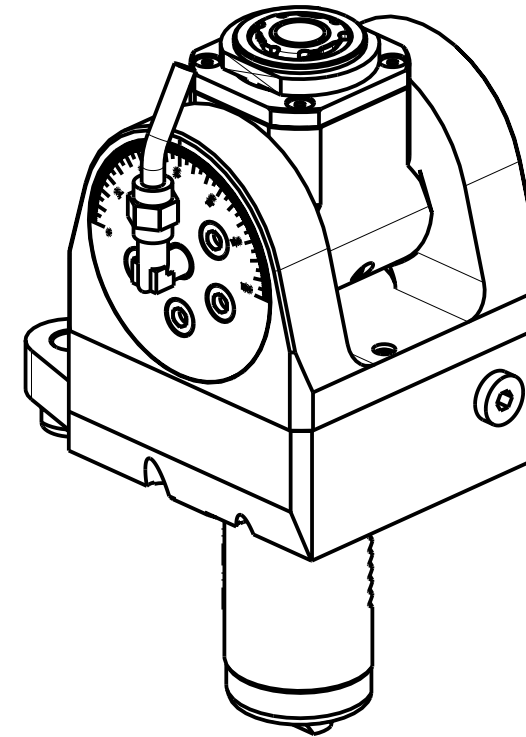
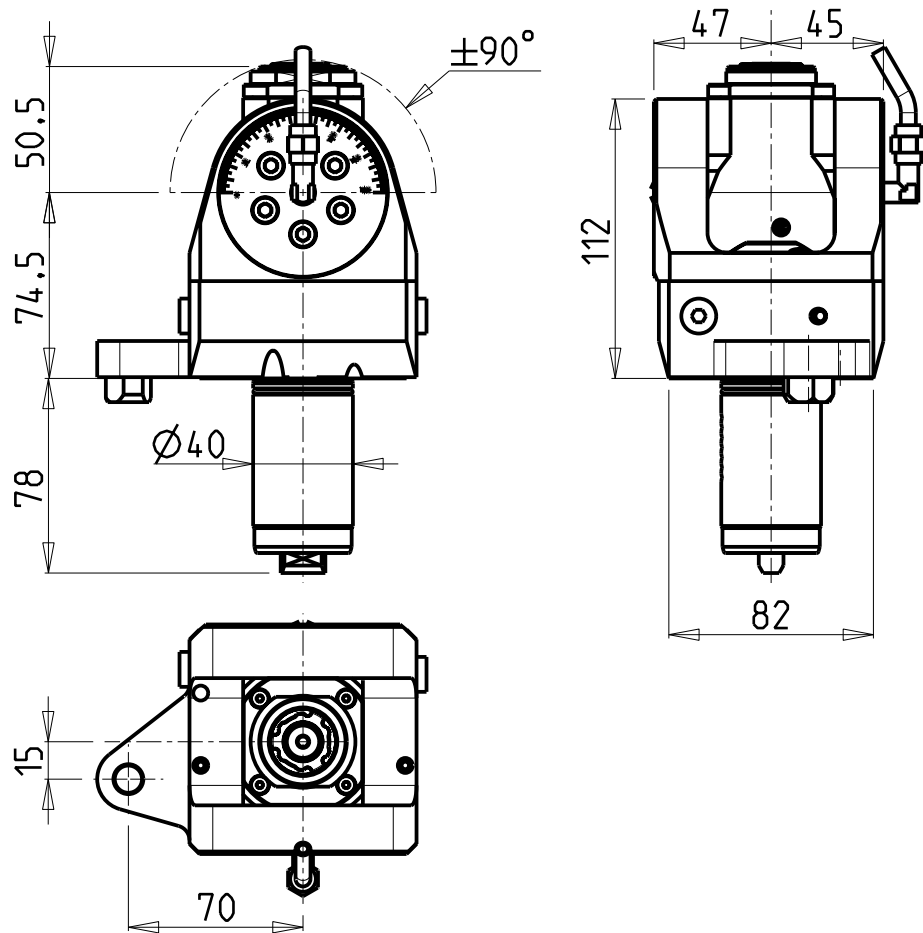

Cod. MT	Mandrino Spindle Spindel	I	RPM	Coppia Max Max Torque Max Drehmoment	Lubrificazione int. Coolant through Innenkuehlung	Lubrificazione est. Ext. coolant Aussenkuehlung	CHIAVI INCLUSE Keys included Schluessel inbegriffen		
MZK0250120	ER A 20	1:1	6000	30Nm	-	X	CHUB36	CHUB22	CHTAER20ZC
MZK0250220	ER A 20	1:1	6000	30Nm	P=70bar	X	CHUB36	CHUB22	CHTAER20ZC

MAZAK
 SQT 15-18M/MS/MY/MSY 12 STAZIONI - SQT200-250M/MS/MY/MSY 12 STAZIONI - QT NEXUS 200-250M/MS/MY/MSY 12 STAZIONI
 QT NEXUS 20011-25011 M/MS/MY/MSY 12 STAZIONI - SUPER QUADREX 200-250M - IVS200/300M

MODULO MOTORIZZATO ORIENTABILE ±90°
 ±90° adjustable angle driven tool
 Angetriebenes Werkzeug schwenkbar ±90°

Subject to change without notice.

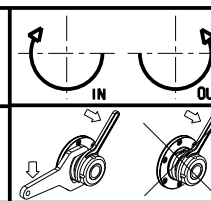

M.T. srl
 Via Casino Albini 480
 Tel. 0541/956034-957884
 Fax 0541/956341
 47842 S. GIOVANNI IN M. (RN)
 e-mail: mtma@mtmarchetti.com
 http://www.mtmarchetti.com



PAGINA MZK335-1-00

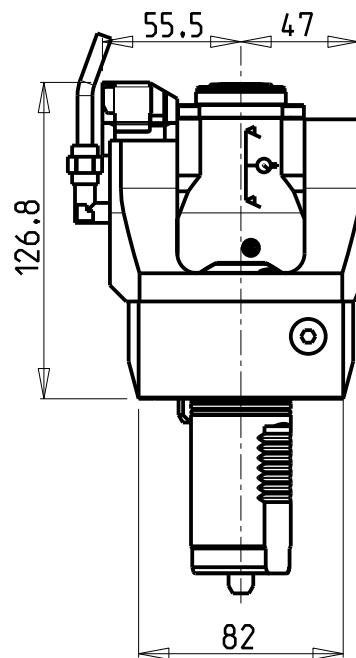
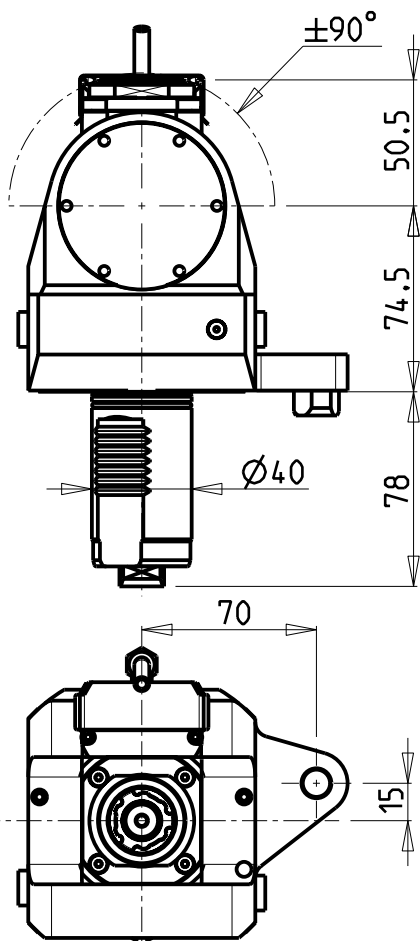

ATTENZIONE - ATTENTION - ACHTUNG

- Per lo smontaggio degli utensili utilizzare sempre la chiave di contrasto come indicato nel manuale d'uso.
- For disassembly of the tools use always the contrast key as mentioned in the user instructions.
- Fuer das Abmontieren der Werkzeuge immer den Gegenschlüssel benutzen wie in der Bedienungsanleitung erwaeht.

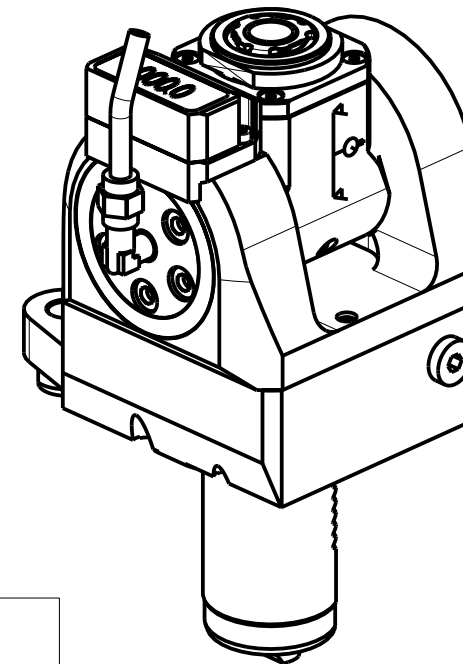

Cod. MT	Mandrino Spindle Spindel	I	RPM	Coppia Max Max Torque Max Drehmoment	Lubrificazione int. Coolant through Innenkuehlung	Lubrificazione est. Ext. coolant Aussenkuehlung	CHIAVI INCLUSE Keys included Schlüssel inbegriffen		
MZK0255120	ER A 20	1:1	6000	30Nm	-	X	CHUB36	CHUB22	CHTAER20ZC
MZK0255220	ER A 20	1:1	6000	30Nm	P=70bar	X	CHUB36	CHUB22	CHTAER20ZC

MAZAK
 SQT 15-18M/MS/MY/MSY 12 STAZIONI - SQT200-250M/MS/MY/MSY 12 STAZIONI - QT NEXUS 200-250M/MS/MY/MSY 12 STAZIONI
 QT NEXUS 20011-25011 M/MS/MY/MSY 12 STAZIONI - SUPER QUADREX 200-250M - IVS200/300M

MODULO MOTORIZZATO ORIENTABILE ±90° CON NONIO DIGITALE
 ±90° adjustable angle driven tool with digital display
 Angetriebenes Werkzeug schwenkbar ±90° mit digital display

Subject to change without notice.

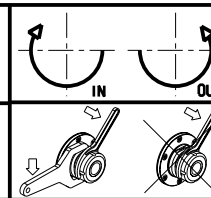

M.T. srl
 Via Casino Albini 480
 Tel. 0541/956034-957884
 Fax 0541/956341
 47842 S. GIOVANNI IN M. (RN)
 e-mail: mtma@mtmarchetti.com
 http://www.mtmarchetti.com



PAGINA MZK335-1-01

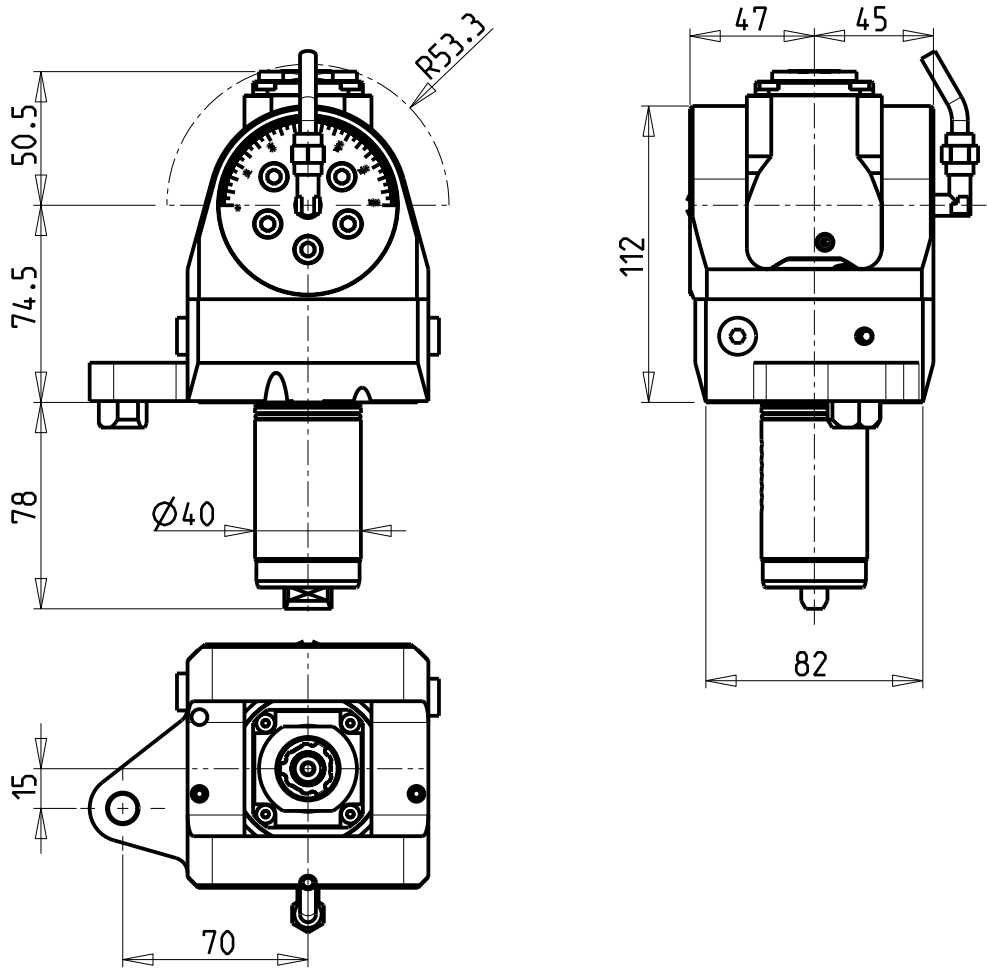

ATTENZIONE - ATTENTION - ACHTUNG

- Per lo smontaggio degli utensili utilizzare sempre la chiave di contrasto come indicato nel manuale d'uso.
- For disassembly of the tools use always the contrast key as mentioned in the user instructions.
- Fuer das Abmontieren der Werkzeuge immer den Gegenschlüssel benutzen wie in der Bedienungsanleitung erwäehnt.

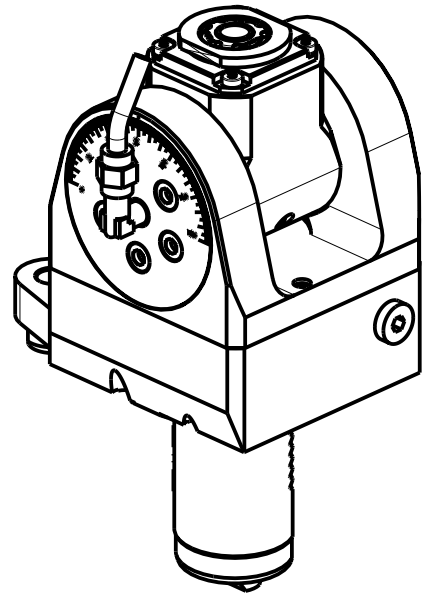

Cod. MT	Mandrino Spindle Spindel	I	RPM	Coppia Max Max Torque Max Drehmoment	Lubrificazione int. Coolant through Innenkuehlung	Lubrificazione est. Ext. coolant Aussenkuehlung	CHIAVI INCLUSE Keys included Schluesssel inbegriffen		
MZK0250316	ERA16	1:2	12000	8Nm	-	X	CHUB19_SP3	CHUB32	CHTAER16ZC
MZK0250416	ERA16	1:2	12000	8Nm	P=70bar	X	CHUB19_SP3	CHUB32	CHTAER16ZC

MAZAK
 SQT 15-18M/MS/MY/MSY 12 STAZIONI - SQT200-250M/MS/MY/MSY 12 STAZIONI - QT NEXUS 200-250M/MS/MY/MSY 12 STAZIONI
 QT NEXUS 20011-25011 M/MS/MY/MSY 12 STAZIONI - SUPER QUADREX 200-250M - IVS200/300M

MODULO MOTORIZZATO ORIENTABILE +/-90° MOLTIPLICATO I=1:2
 +/-90° adjustable angle driven tool geared-up I=1:2
 Angetriebenes Werkzeug schwenkbar +/-90° uebersetzt I=1:2

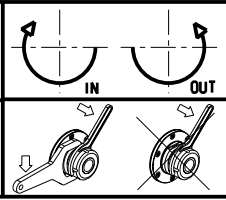

M.T. srl
 Via Casino Albini 480
 Tel. 0541/956034-957884
 Fax 0541/956341
 47842 S. GIOVANNI IN M. (RN)
 e-mail: mtma@mtmarchetti.com
 http://www.mtmarchetti.com



PAGINA MZK336-1-00

Subject to change without notice.

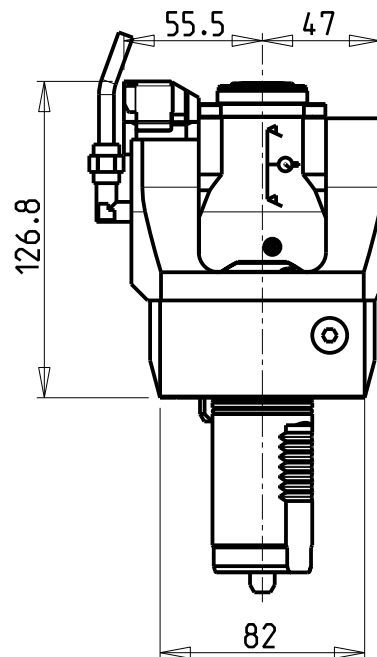
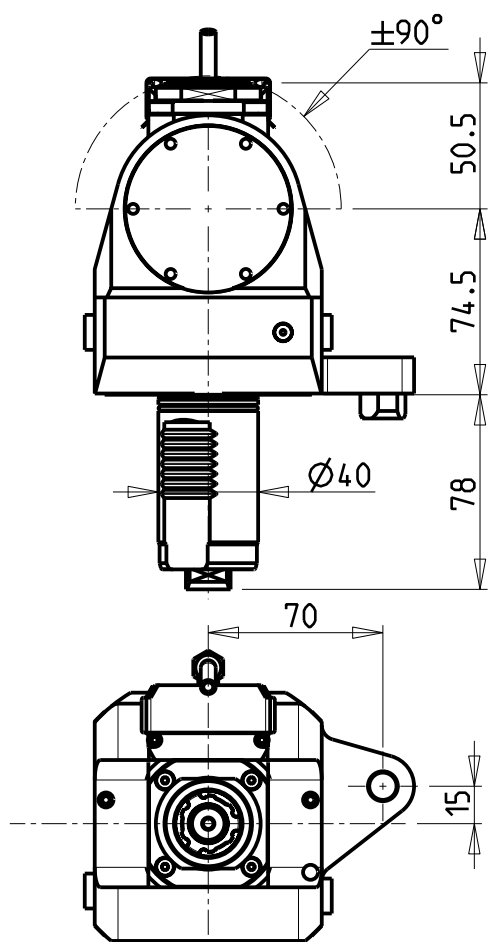

ATTENZIONE - ATTENTION - ACHTUNG

- Per lo smontaggio degli utensili utilizzare sempre la chiave di contrasto come indicato nel manuale d'uso.
- For disassembly of the tools use always the contrast key as mentioned in the user instructions.
- Fuer das Abmontieren der Werkzeuge immer den Gegenschlüssel benutzen wie in der Bedienungsanleitung erwäehnt.

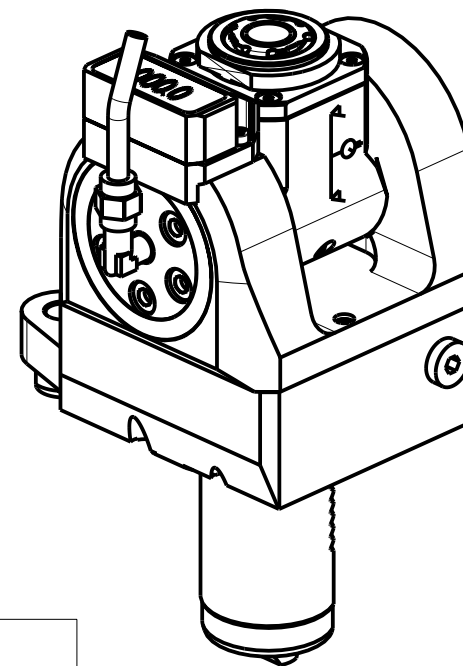

Cod. MT	Mandrino Spindle Spindel	I	RPM	Coppia Max Max Torque Max Drehmoment	Lubrificazione int. Coolant through Innenkuehlung	Lubrificazione est. Ext. coolant Aussenkuehlung	CHIAVI INCLUSE Keys included Schluesssel inbegriffen		
MZK0255316	ERA16	1:2	12000	8Nm	-	X	CHUB19_SP3	CHUB32	CHTAER16ZC
MZK0255416	ERA16	1:2	12000	8Nm	P=70bar	X	CHUB19_SP3	CHUB32	CHTAER16ZC

MAZAK
 SQT 15-18M/MS/MY/MSY 12 STAZIONI - SQT200-250M/MS/MY/MSY 12 STAZIONI - QT NEXUS 200-250M/MS/MY/MSY 12 STAZIONI
 QT NEXUS 20011-25011 M/MS/MY/MSY 12 STAZIONI - SUPER QUADREX 200-250M - IVS200/300M

MODULO MOTORIZZATO ORIENTABILE ±90° MOLTIPLICATO I=1:2 CON NONIO DIGITALE
 +/-90° adjustable angle driven tool geared-up I=1:2 with digital display
 Angetriebenes Werkzeug schwenkbar +/-90° uebersetzt I=1:2 mit digital display

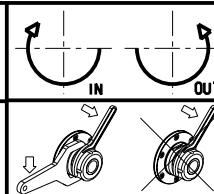

M.T. srl
 Via Casino Albini 480
 Tel. 0541/956034-957884
 Fax 0541/956341
 47842 S. GIOVANNI IN M. (RN)
 e-mail: mtma@mtmarchetti.com
 http://www.mtmarchetti.com



PAGINA MZK336-1-01

Subject to change without notice.

09/2022

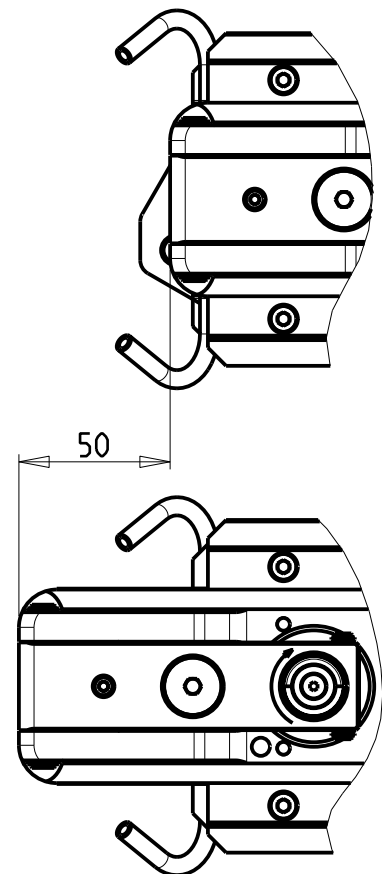
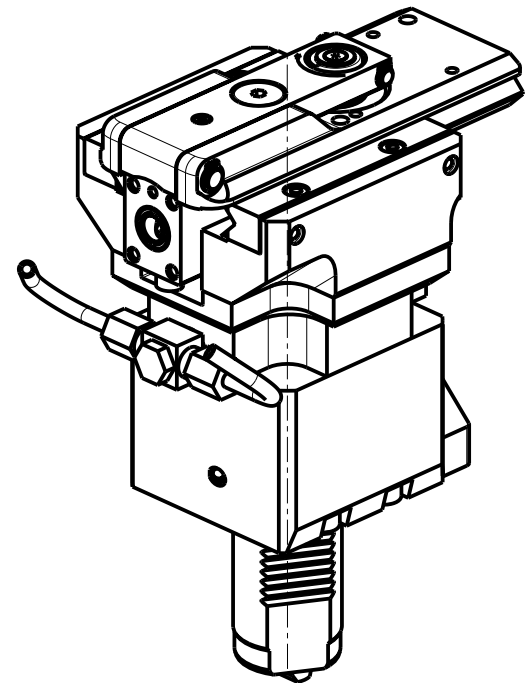
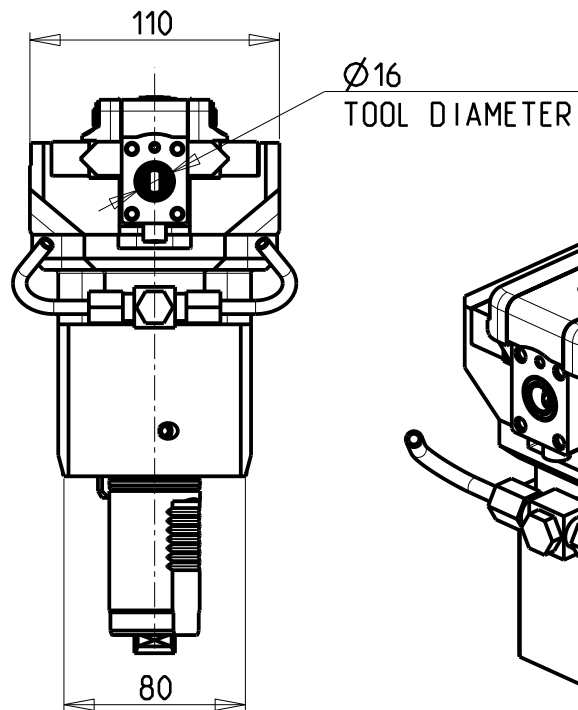
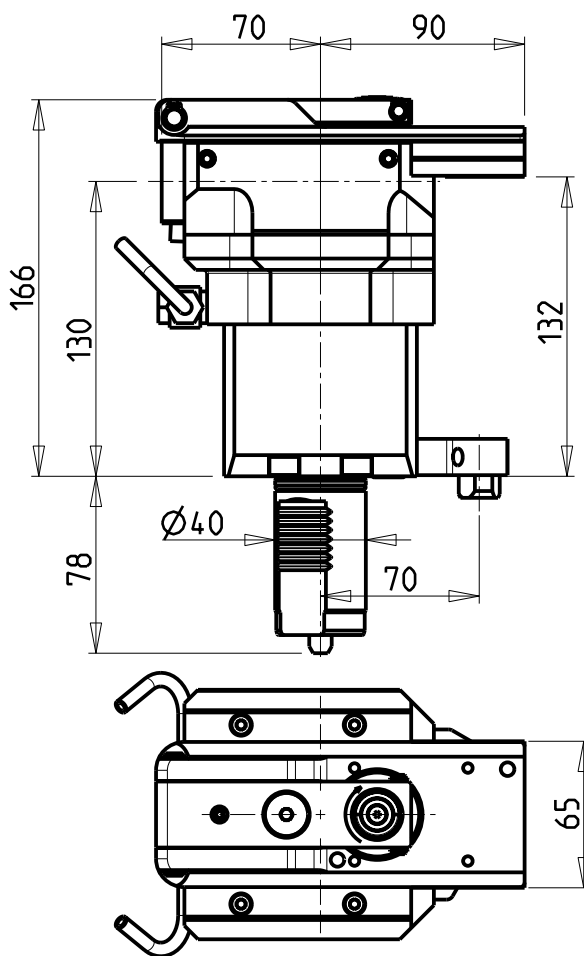

DOTAZIONI - SUPPLIED WITH - AUSSTATTUNG

N°1 Boccola di riduz. Ø16-Ø12 e N°1 Boccola di riduz. Ø16-Ø10
 N°1 Reduction bush Ø16-Ø12 and N°1 Reduction bush Ø16-Ø10
 N°1 Reduzierbuchsen Ø16-Ø12 und N°1 Reduzierbuchsen Ø16-Ø10

PER UTENSILI STOZZATORI VEDI PAG. TBL400-1-00
 FOR DRIVEN SLOTTING TOOL CUTTING-TOOLS SEE PAGE TBL400-1-00
 FÜR NUTENSTOSS-WERKZEUG SCHNEIDWERKZEUGE SIEHE SEITE TBL400-1-00

Cod. MT	I	RPM MAX	Lubr. esterna Ext. coolant Aussenkuehlung
MZK0440100	4:1	2000	X

MAZAK
 SQT 15-18M/MS/MY/MSY 12 STAZIONI - SQT200-250M/MS/MY/MSY 12 STAZIONI - QT NEXUS 200-250M/MS/MY/MSY 12 STAZIONI
 QT NEXUS 20011-25011 M/MS/MY/MSY 12 STAZIONI - SUPER QUADREX 200-250M

MODULO MOTORIZZATO STOZZATORE CORSA 50mm H=130mm
 Slotting driven tool 50mm stroke H=130mm
 Keilnutenstossmaschine 50mm Hub H=130mm

Subject to change without notice.

M.T. srl
 Via Casino Albini 480
 Tel. 0541/956034-957884
 Fax 0541/956341
 47842 S. GIOVANNI IN M. (RN)
 e-mail: mtma@tmarchetti.com
 http://www.tmmarchetti.com



PAGINA MZK360-1-00

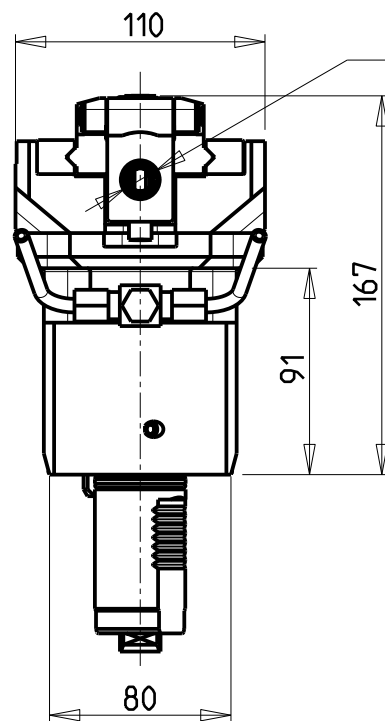
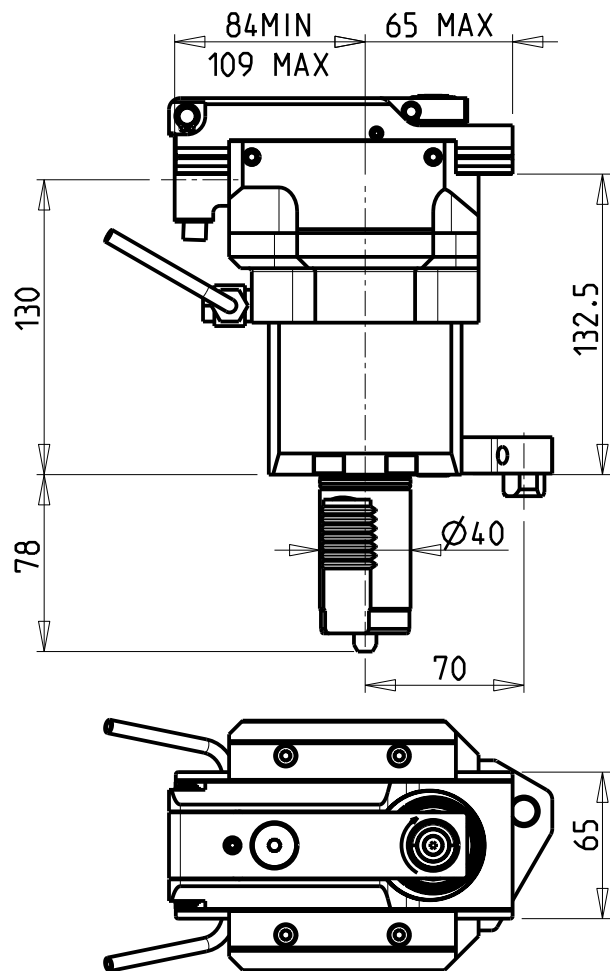

Ø16
TOOL DIAMETER

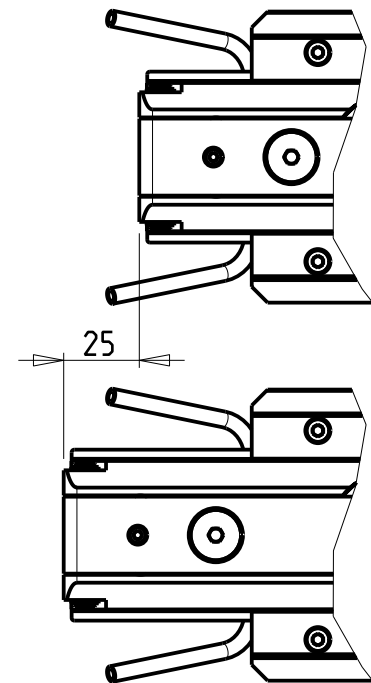
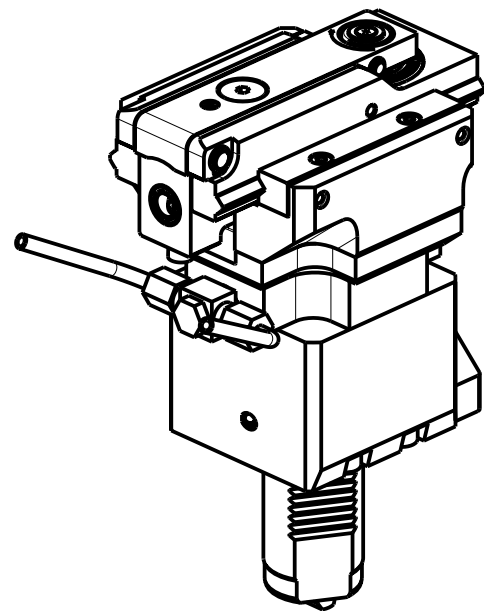

DOTAZIONI - SUPPLIED WITH - AUSSTATTUNG

N°1 Boccola di riduz. Ø16-Ø12 e N°1 Boccola di riduz. Ø16-Ø10
 N°1 Reduction bush Ø16-Ø12 and N°1 Reduction bush Ø16-Ø10
 N°1 Reduzierbuchsen Ø16-Ø12 und N°1 Reduzierbuchsen Ø16-Ø10

PER UTENSILI STOZZATORI VEDI PAG. TBL400-1-00
 FOR DRIVEN SLOTTING TOOL CUTTING-TOOLS SEE PAGE TBL400-1-00
 FÜR NUTENSTOSS-WERKZEUG SCHNEIDWERKZEUGE SIEHE SEITE TBL400-1-00

Cod. MT	I	RPM MAX	Lubr. esterna Ext. coolant Aussenkuehlung
MZK0440200	4:1	2400	X

MAZAK
 SQT 15-18M/MS/MY/MSY 12 STAZIONI - SQT200-250M/MS/MY/MSY 12 STAZIONI - QT NEXUS 200-250M/MS/MY/MSY 12 STAZIONI
 QT NEXUS 20011-25011 M/MS/MY/MSY 12 STAZIONI - SUPER QUADREX 200-250M
 MODULO MOTORIZZATO STOZZATORE CORSA 25mm H=130mm
 Slotting driven tool 25mm stroke H=130mm
 Keilnutenstossmaschine 25mm Hub H=130mm

M.T. srl
 Via Casino Albini 480
 Tel. 0541/956034-957884
 Fax 0541/956341
 47842 S. GIOVANNI IN M. (RN)
 e-mail: mtma@mtmarchetti.com
 http://www.mtmarchetti.com



PAGINA MZK360-1-01

Subject to change without notice.

09/2022

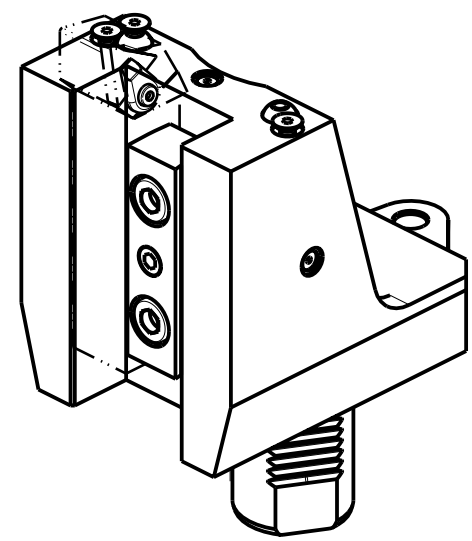
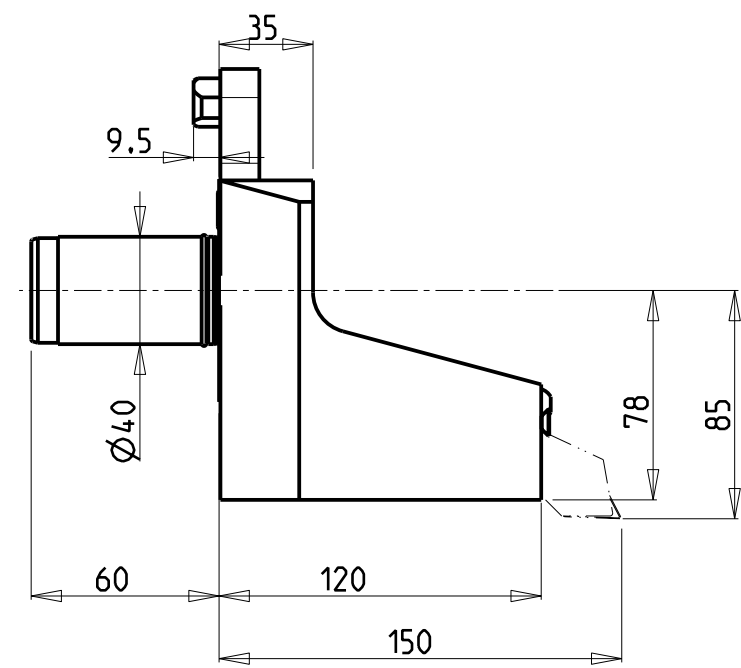
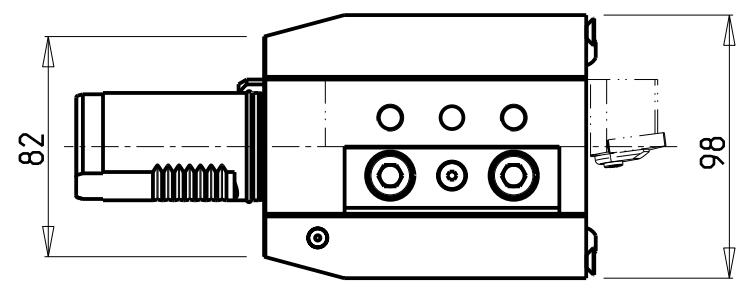
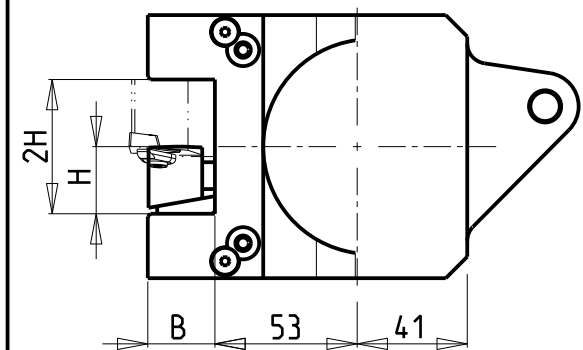

Cod. MT	N°Utensili N°Tools N°Werkzeuge	Misure Dimensions Masse	B	H
MZK0032500	1	mm	25	25
MZK0032540	1	inch	1"	1"

MAZAK
 SQT 15-18M/MS/MY/MSY 12 STAZIONI - SQT200-250M/MS/MY/MSY 12 STAZIONI - QT NEXUS 200-250M/MS/MY/MSY 12 STAZIONI
 QT NEXUS 20011-25011 M/MS/MY/MSY 12 STAZIONI - SUPER QUADREX 200-250M

PORTAUTENSILE RADIALE SINGOLO QD=25mm / QD=1"
 Radial single static tool QD=25mm / QD=1"
 Radial Single-Werkzeughalter QD=25mm / QD=1"

Subject to change without notice.

M.T. srl
 Via Casino Albini 480
 Tel. 0541/956034-957884
 Fax 0541/956341
 47842 S. GIOVANNI IN M. (RN)
 e-mail: mtma@mtmarchetti.com
 http://www.mtmarchetti.com



PAGINA MZK423-1-00

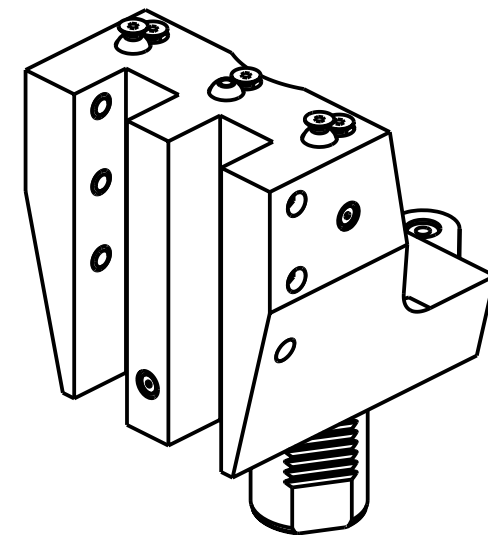
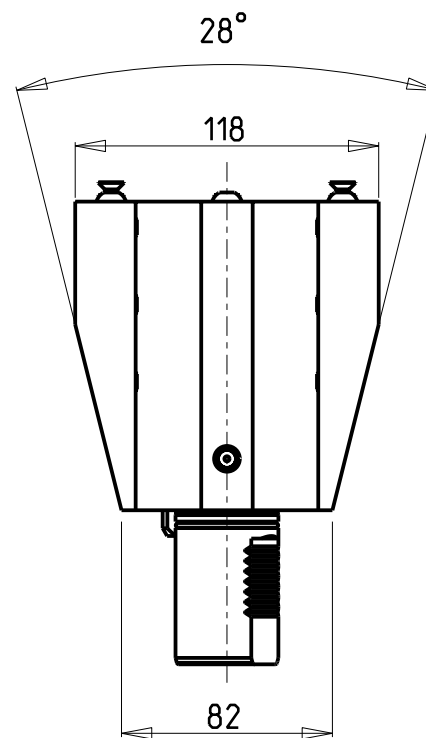
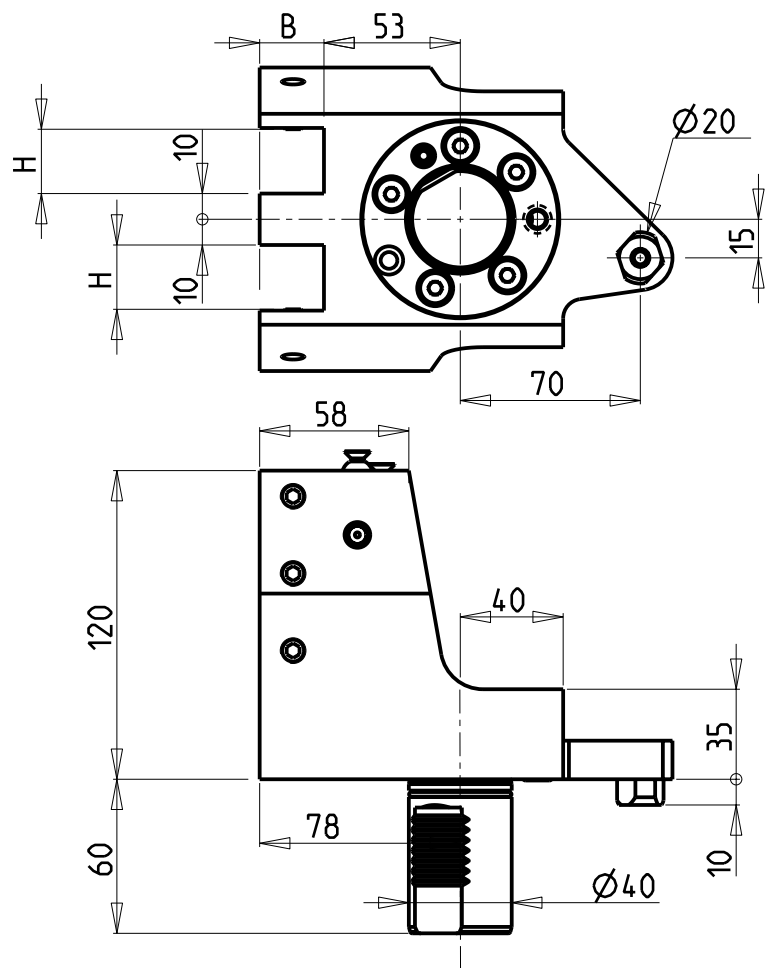

Cod. MT	Lubr.esterna Ext. coolant Aussenkuehlung	Misure Dimensions Masse	H	B
MZK1092500	X	mm	25	25

MAZAK
 SQT 15-18M/MS/MY/MSY 12 STAZIONI - SQT200-250M/MS/MY/MSY 12 STAZIONI - QT NEXUS 200-250M/MS/MY/MSY 12 STAZIONI
 QT NEXUS 200II-250II M/MS/MY/MSY 12 STAZIONI

PORTAUTENSILE RADIALE SOVRAPPOSTO QD=25mm
 Radial single side twin static tool QD=25mm
 Radial Werkzeughalter ueberlagert QD=25mm

M.T. srl
 Via Casino Albini 480
 Tel. 0541/956034-957884
 Fax 0541/956341
 47842 S. GIOVANNI IN M. (RN)
 e-mail: mtma@mtmarchetti.com
 http://www.mtmarchetti.com



PAGINA MZK442-1-00

Subject to change without notice.

09/2022

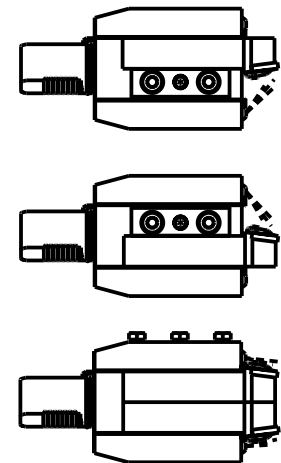
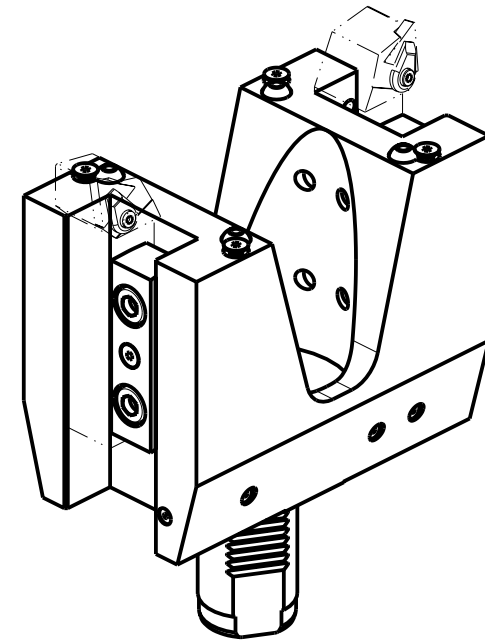
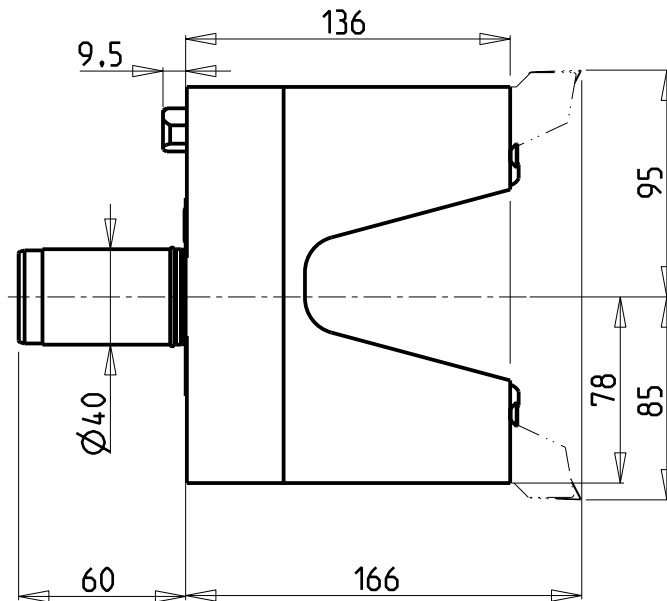
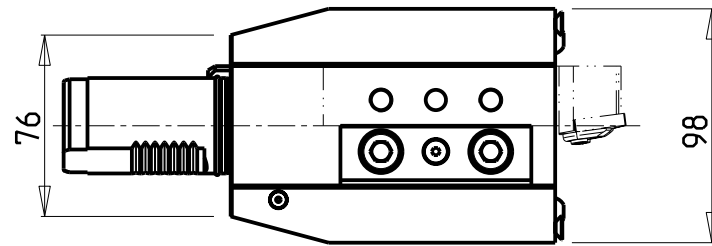
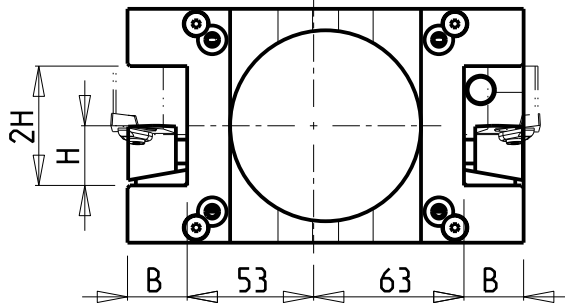

Cod. MT	N°Utensili N°Tools N°Werkzeuge	Misure Dimensions Masse	B	H
MZK0042500	2	mm	25	25
MZK0042540	2	inch	1"	1"

MAZAK
 SQT 15-18M/MS/MY/MSY 12 STAZIONI - SQT200-250M/MS/MY/MSY 12 STAZIONI - QT NEXUS 200-250M/MS/MY/MSY 12 STAZIONI
 QT NEXUS 20011-25011 M/MS/MY/MSY 12 STAZIONI - SUPER QUADREX 200-250M

PORTAUTENSILE RADIALE DOPPIO QD=25mm / QD=1"
 Radial double static tool QD=25mm / QD=1"
 Radial Doppel-Werkzeughalter QD=25mm / QD=1"

Subject to change without notice.

M.T. srl
 Via Casino Albini 480
 Tel. 0541/956034-957884
 Fax 0541/956341
 47842 S. GIOVANNI IN M. (RN)
 e-mail: mtma@mtmarchetti.com
 http://www.mtmarchetti.com



PAGINA MZK453-1-00

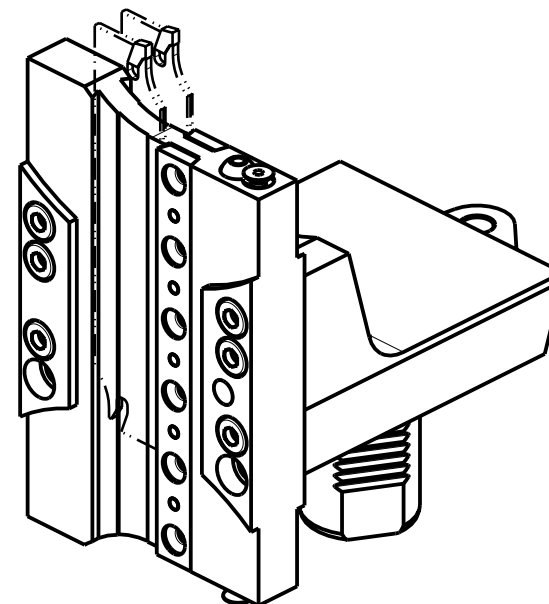
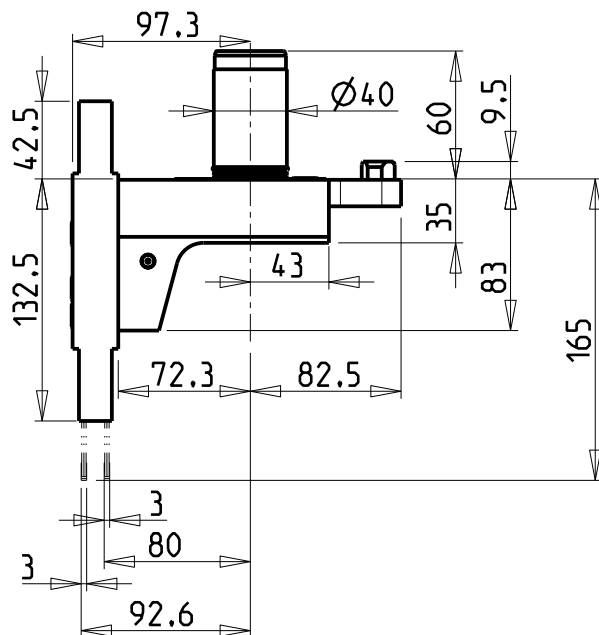
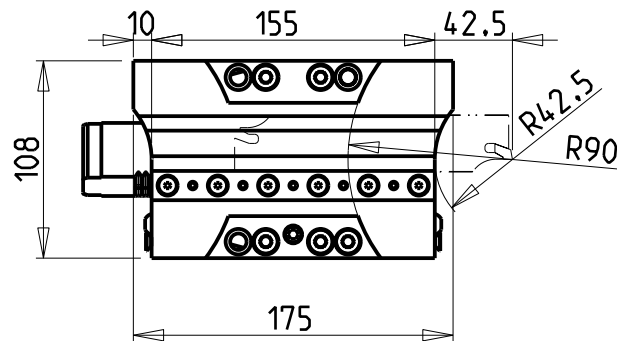
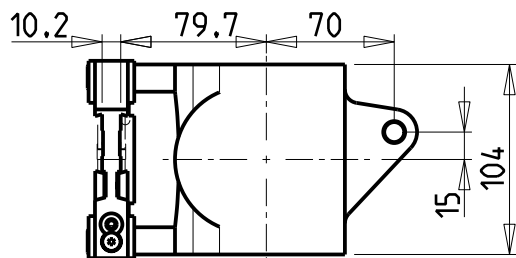

POSSIBILITA' DI LAVORO M3/M4
 OPTION OF M3/M4 WORKING
 ARBEITSMÖGLICHKEIT M3/M4

DOTAZIONI - SUPPLIED WITH - AUSSTATTUNG

N°1 - LAMA - BLADE - KLINGE ISCAR H=32 Sp. 3/4mm
 (KENNAMETAL OPTIONAL)

N°10 - INSERTI - INSERTS - EINLAGEN

N°1 - CHIAVE A T PER MONTAGGIO INSERTI
 - T-WRENCH FOR INSERT SET UP
 - T-SCHLUESSEL FUER EINSATZSTUECK-MONTAGE

Cod. MT
 N°Utensili
 N° Tools
 N° Werkzeuge

MZK0060132 1

MAZAK
 SQT 15-18M/MS/MY/MSY 12 STAZIONI - SQT200-250M/MS/MY/MSY 12 STAZIONI - QT NEXUS 200-250M/MS/MY/MSY 12 STAZIONI
 QT NEXUS 20011-25011 M/MS/MY/MSY 12 STAZIONI - SUPER QUADREX 200-250M

PORTAUTENSILE PER LAMA DOPPIO
 Radial double blade holder
 Radial Doppel-Abstechhalter

Subject to change without notice.

M.T. srl

Via Casino Albini 480
 Tel. 0541/956034-957884
 Fax 0541/956341
 47842 S. GIOVANNI IN M. (RN)
 e-mail: mtma@mtmarchetti.com
 http://www.mtmarchetti.com



PAGINA MZK520-1-00

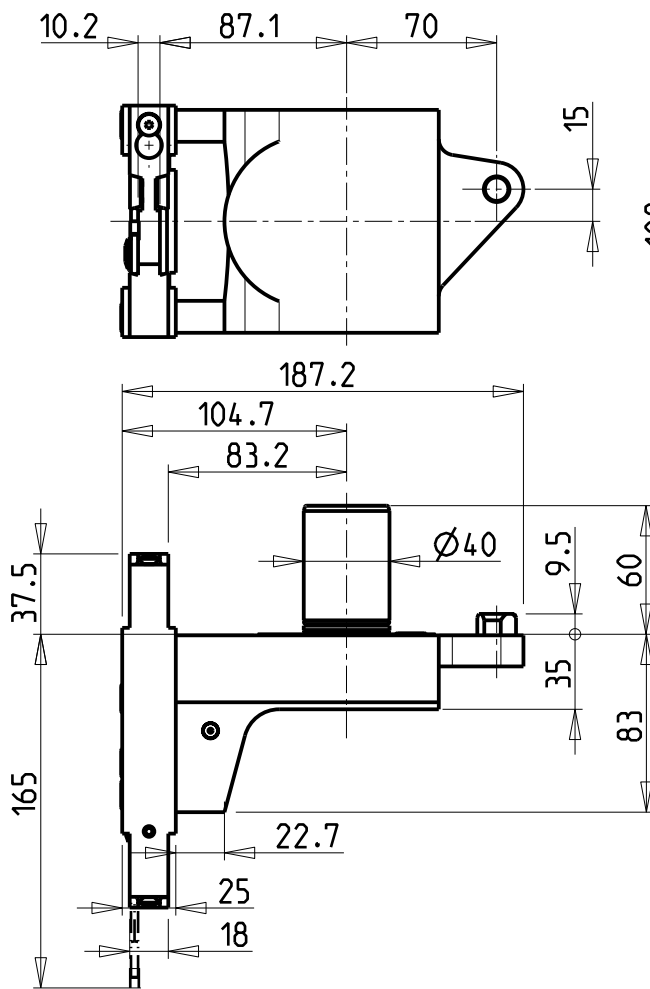

POSSIBILITA' DI LAVORO M3/M4
 OPTION OF M3/M4 WORKING
 ARBEITSMÖGLICHKEIT M3/M4

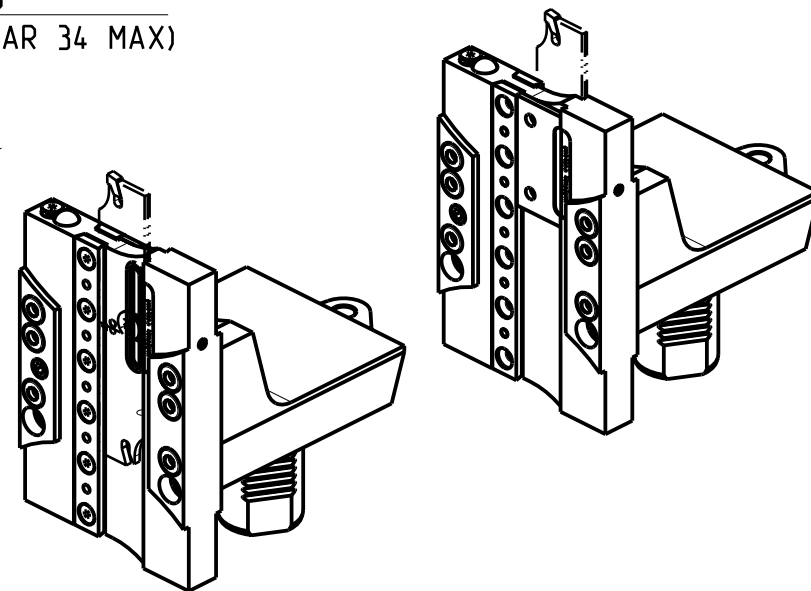

KIT LAME NON INCLUSI (OPZIONALI)
BLADES NOT SUPPLIED WITH (OPTIONAL)
KLINGEN NICHT INBEGRIFFEN (OPTIONAL)

- LAMA-BLADE-KLINGE SANDVIK H=32 sp.3 cod. QD_NN2G60C 25A
 +INSERTI-INSERTS-EINLAGEN cod. QD_NG_0300_0002_CM_1145 (10 pz.)
- LAMA-BLADE-KLINGE SANDVIK H=32 sp.4 cod. QD_NN2H60C 25A
 +INSERTI-INSERTS-EINLAGEN cod. QD_NH_0400_0002_CM_1145 (10 pz.)
- LAMA-BLADE-KLINGE ISCAR H=32 sp.3 cod. SGFH_32K_3
 +INSERTI-INSERTS-EINLAGEN cod. 6011365 (10pz.)
- LAMA-BLADE-KLINGE ISCAR H=32 sp.4 cod. SGFH_32K_4
 +INSERTI-INSERTS-EINLAGEN cod. 6011366 (10pz.)
- LAMA-BLADE-KLINGE WALTER H=32 sp.3 cod. G2042.32N-3T45SX-P
 +INSERTI-INSERTS-EINLAGEN cod. SX-3E300N02-CE4 WSM33S (10pz.) + CHIAVE-KEY cod. FS1494
- LAMA-BLADE-KLINGE WALTER H=32 sp.4 cod. G2042.32N-4T50SX-P
 +INSERTI-INSERTS-EINLAGEN cod. SX-4E400N02-CE4 WSM33S (10pz.) + CHIAVE-KEY cod. FS1494

Cod. MT	N°Utensili N°Tools N°Werkzeuge	Lubr.esterna Ext. coolant Aussenkuehlung	Lubr.interna Coolant through Innenkuehlung
MZK0570132	1	X	P=70bar

MAZAK
 SQT 15-18M/MS/MY/MSY 12 STAZIONI - SQT200-250M/MS/MY/MSY 12 STAZIONI - QT NEXUS 200-250M/MS/MY/MSY 12 STAZIONI
 QT NEXUS 20011-25011 M/MS/MY/MSY 12 STAZIONI - SUPER QUADREX 200-250M

PORTAUTENSILE PER LAMA DOPPIO CON LUBRIFICAZIONE INTERNA
 Radial double blade holder with internal coolant
 Radial Doppel-Abstechhalter mit Innenkuehlung

M.T. srl
 Via Casino Albini 480
 Tel. 0541/956034-957884
 Fax 0541/956341
 47842 S. GIOVANNI IN M. (RN)
 e-mail: mtma@mtmarchetti.com
 http://www.mtmarchetti.com



PAGINA MZK520-1-04

Subject to change without notice.

09/2022

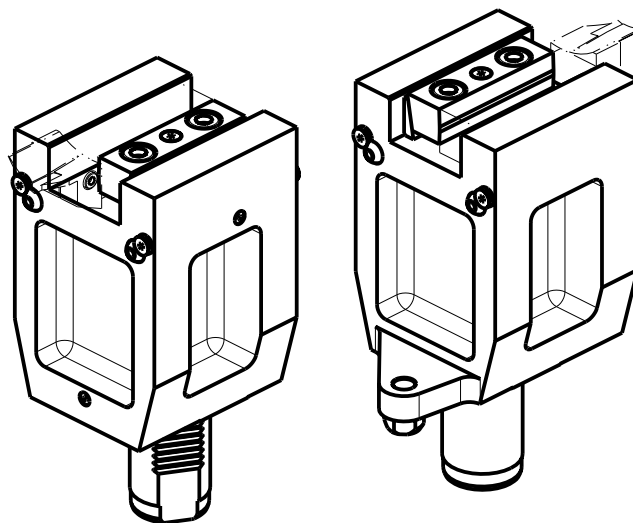
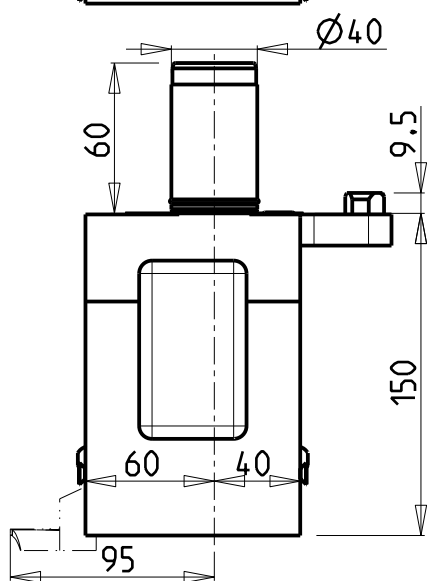
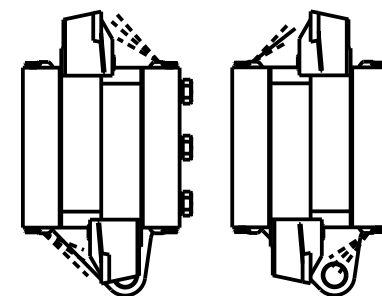
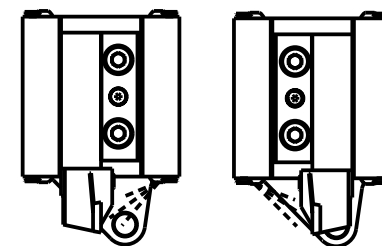
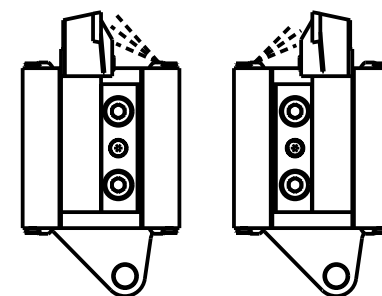
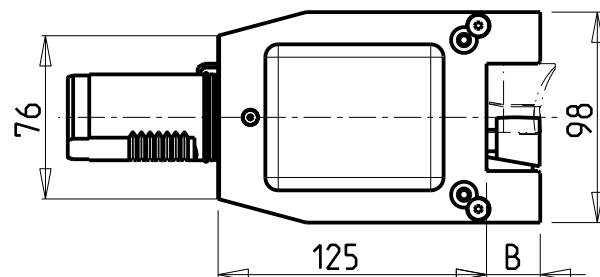
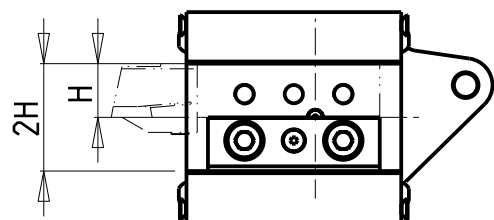

Cod. MT	N°Utensili N° Tools N° Werkzeuge	Misure Dimensions Masse	B	H
MZK0052500	1	mm	25	25
MZK0052540	1	inch	1"	1"

MAZAK
 SQT 15-18M/MS/MY/MSY 12 STAZIONI - SQT200-250M/MS/MY/MSY 12 STAZIONI - QT NEXUS 200-250M/MS/MY/MSY 12 STAZIONI
 QT NEXUS 20011-25011 M/MS/MY/MSY 12 STAZIONI - SUPER QUADREX 200-250M
 PORTAUTENSILE ASSIALE SINGOLO QD=25mm / QD=1"
 Axial single static tool QD=25mm / QD=1"
 Axial Single-Werkzeughalter QD=25mm / QD=1"

M.T. srl
 Via Casino Albini 480
 Tel. 0541/956034-957884
 Fax 0541/956341
 47842 S. GIOVANNI IN M. (RN)
 e-mail: mtma@mtmarchetti.com
 http://www.mtmarchetti.com



PAGINA MZK552-1-00

Subject to change without notice.

09/2022

KIT ADDUZIONE INTERNA (OPZIONALE)
 KIT FOR INTERNAL COOLANT (OPTIONAL)
 KIT FUER INTERNE KUEHLMITTELZUFUHR (OPTIONAL)
 $\varnothing 40$ cod. KIT1003003
 $\varnothing 1 \frac{1}{2}$ " cod. KIT1003004

SOLO GUARNIZIONE (OPZIONALE)
 ONLY SEAL (OPTIONAL)
 NUR DICHTUNG (OPTIONAL)
 cod. 0520013

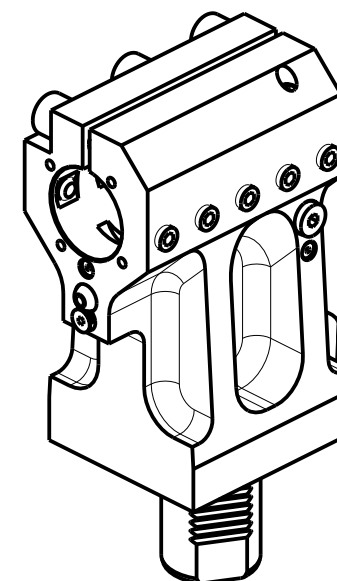
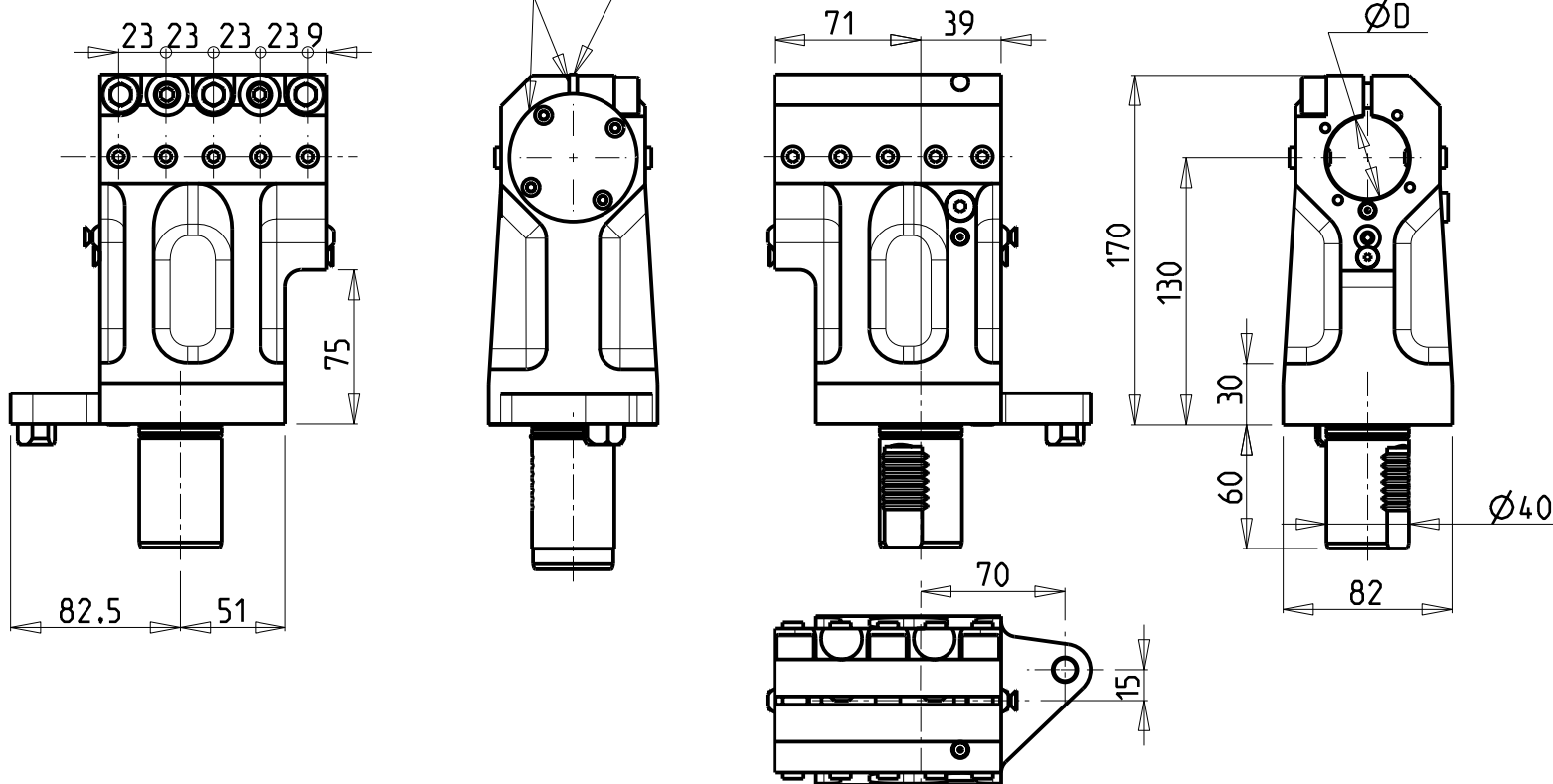

Cod. MT	N°Utensili N° Tools N° Werkzeuge	Lubrificazione int. opzionale Coolant through optional Innenkuehlung Optional	Lubrificazione est. Ext. coolant Aussenkuehlung	Misure Dimensions Masse	D	H
MZK0074000	1	X	X	mm	40	130
MZK0073810	1	X	X	inch	1 1/2"	130

PER BOCCOLE DI RIDUZIONE VEDI PAG. TBL150-1-00
 FOR REDUCING BUSHINGS SEE PAGE TBL150-1-00
 FUR REDUZIERBUCHSE SIEHE SEITE TBL150-1-00

MAZAK
 SQT 15-18M/MS/MY/MSY 12 STAZIONI - SQT200-250M/MS/MY/MSY 12 STAZIONI - QT NEXUS 200-250M/MS/MY/MSY 12 STAZIONI
 QT NEXUS 20011-25011 M/MS/MY/MSY 12 STAZIONI - SUPER QUADREX 200-250M
 PORTAUTENSILE ASSIALE PER BARENO $\varnothing 40$ mm / $\varnothing 1 \frac{1}{2}$ " H=130mm
 Axial single boring bar holder $\varnothing 40$ mm / $\varnothing 1 \frac{1}{2}$ " H=130mm
 Axial Bohrhalter $\varnothing 40$ mm / $\varnothing 1 \frac{1}{2}$ " H=130mm

M.T. srl
 Via Casino Albini 480
 Tel. 0541/956034-957884
 Fax 0541/956341
 47842 S. GIOVANNI IN M. (RN)
 e-mail: mtma@tmarchetti.com
 http://www.tmmarchetti.com



PAGINA MZK630-1-20

Subject to change without notice.

09/2022

KIT ADDUZIONE INTERNA (OPZIONALE)
 KIT FOR INTERNAL COOLANT (OPTIONAL)
 KIT FUER INTERNE KUEHLMITTELZUFUHR (OPTIONAL)
 Ø40 cod. KIT1000003
 Ø1 1/2" cod. KIT1000004

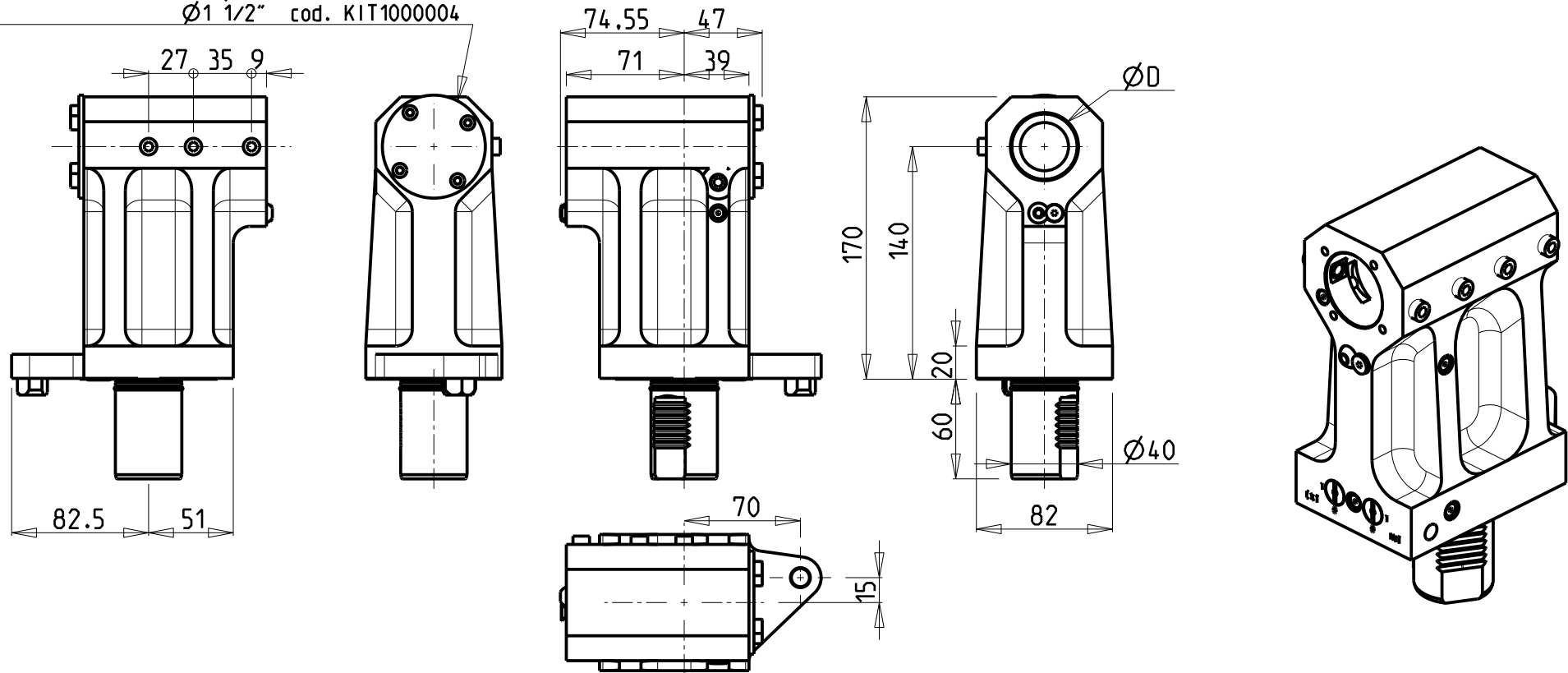

PER BOCCOLE DI RIDUZIONE VEDI PAG. TBL150-1-00
 FOR REDUCING BUSHINGS SEE PAGE TBL150-1-00
 FÜR REDUZIERBUCHSE SIEHE SEITE TBL150-1-00

Cod. MT	N°Utensili N°Tools N°Werkzeuge	Lubrificazione int. opzionale Coolant through optional Innenkühlung Optional	Lubrificazione est. Ext. coolant "Aussenkühlung"	Misure Dimensions Masse	D	H
MZK0084000	1	X	X	mm	40	140
MZK0083810	1	X	X	inch	1 1/2"	140

MAZAK
 SQT 15-18M/MS/MY/MSY 12 STAZIONI - SQT200-250M/MS/MY/MSY 12 STAZIONI - QT NEXUS 200-250M/MS/MY/MSY 12 STAZIONI
 QT NEXUS 20011-25011 M/MS/MY/MSY 12 STAZIONI - SUPER QUADREX 200-250M

PORTAUTENSILE ASSIALE PER BARENO Ø40mm / Ø1 1/2" H=140mm
 Axial single boring bar holder Ø40mm / Ø1 1/2" H=140mm
 Axial Bohrhälter Ø40mm / Ø1 1/2" H=140mm

Subject to change without notice.

M.T. srl
 Via Casino Albini 480
 Tel. 0541/956034-957884
 Fax 0541/956341
 47842 S. GIOVANNI IN M. (RN)
 e-mail: mtma@mtmarchetti.com
 http://www.mtmarchetti.com



PAGINA MZK640-1-10

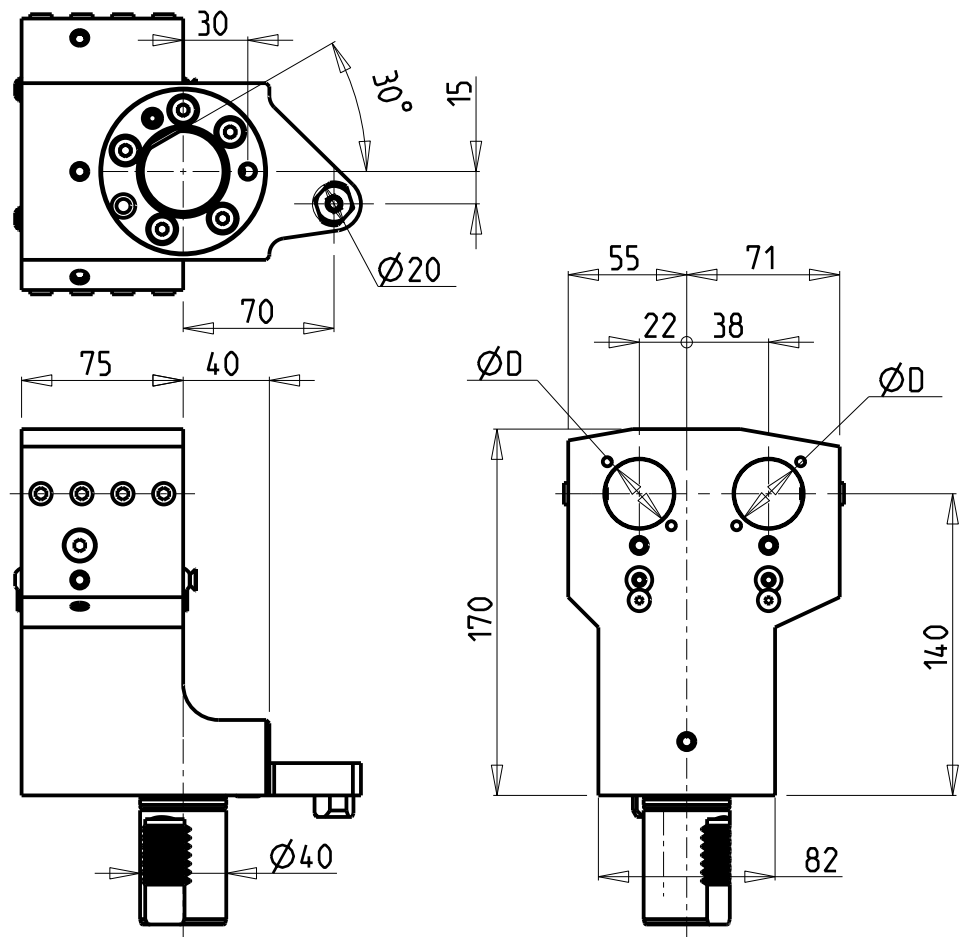

KIT ADDUZIONE INTERNA (OPZIONALE)
 KIT FOR INTERNAL COOLANT (OPTIONAL)
 KIT FUER INTERNE KUEHLMITTELZUFUHR (OPTIONAL)
 Ø32 cod. KIT1000001

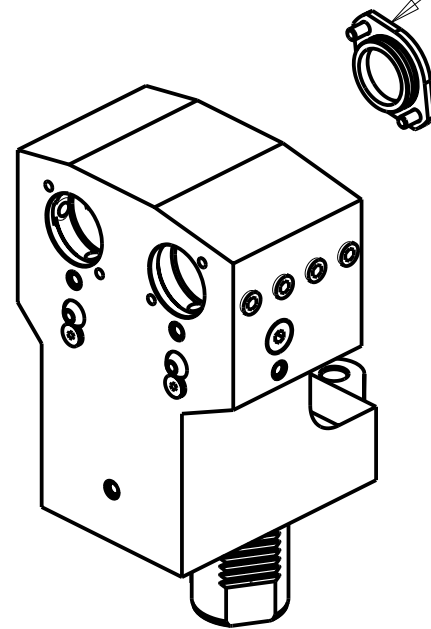

Cod. MT	N°Utensili N°Tools N°Werkzeuge	Lubrificazione int. opzionale Coolant through optional Innenkuehlung Optional	Lubrificazione est. Ext. coolant Aussenkuehlung	Misure Dimensions Masse	D
MZK1073200	2	X	X	mm	32

MAZAK
 MOD: SQT15-18M/MS/MY/MSY - SQT200-250M/MS/MY/MSY 12 STAZ.
 QT NEXUS 200-250M/MS/MY/MSY 12 STAZ. - QT NEXUS 20011-25011M/MS/MY/MSY 12 STAZ.
 PORTAUTENSILE ASSIALE PER BARENO 2 POSIZIONI IN Y Ø32mm
 Axial double boring bar holder 2 positions in Y Ø32mm
 Axial Bohrhalter 2 Positionen in Y Ø32mm

M.T. srl
 Via Casino Albini 480
 Tel. 0541/956034-957884
 Fax 0541/956341
 47842 S. GIOVANNI IN M. (RN)
 e-mail: mtma@mtmarchetti.com
 http://www.mtmarchetti.com



PAGINA MZK866-1-40

Subject to change without notice.

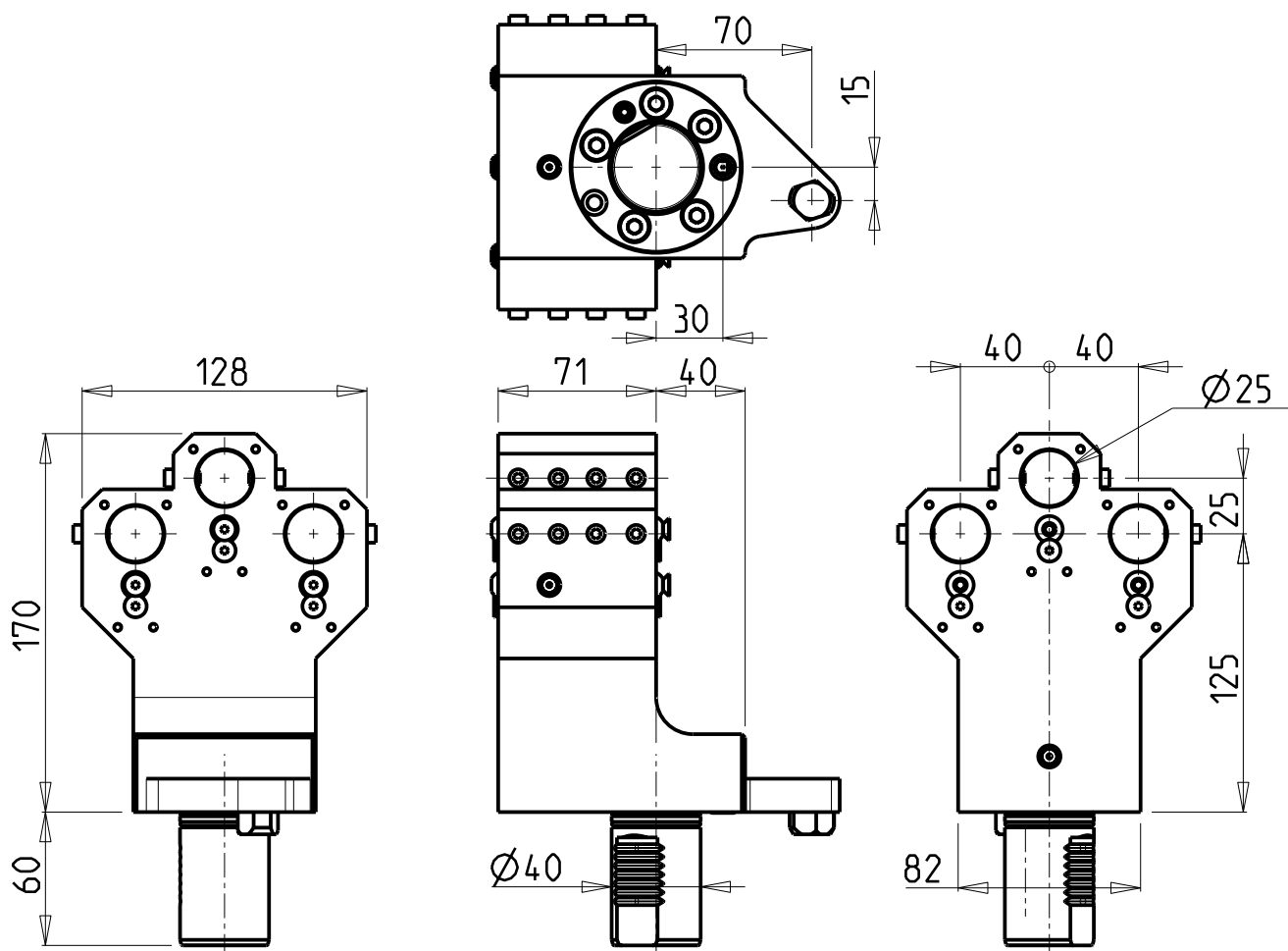

KIT ADDUZIONE INTERNA (OPZIONALE)
 KIT FOR INTERNAL COOLANT (OPTIONAL)
 KIT FUER INTERNE KUEHLMITTELZUFUHR (OPTIONAL)
 cod. KIT1000024

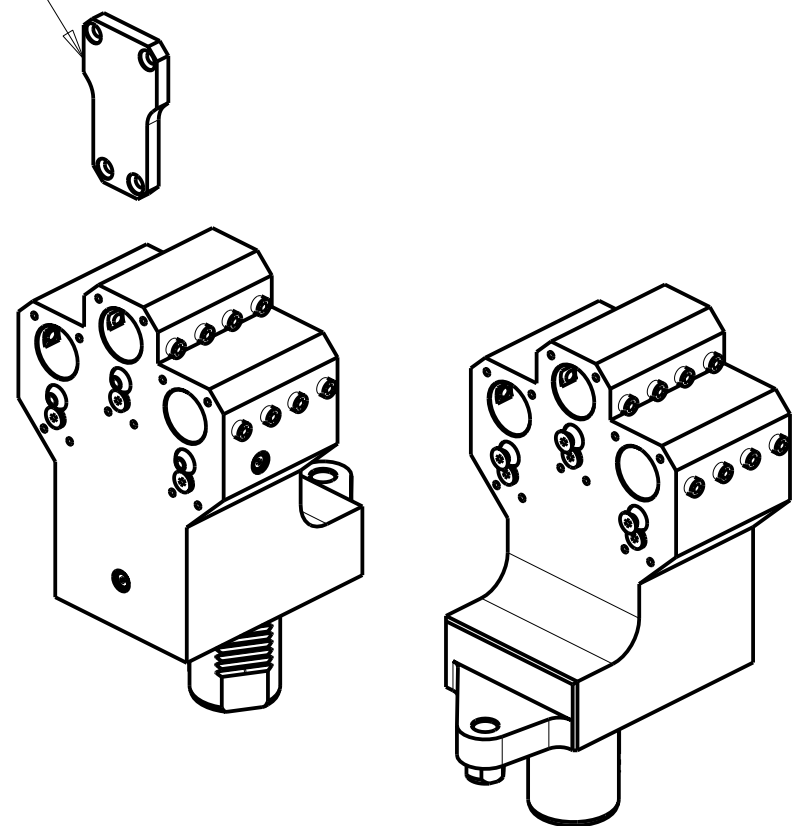

Cod. MT	N°Utensili N°Tools N°Werkzeuge	Lubrificazione int. Coolant through Innenkuehlung	Lubrificazione est. Ext. coolant Aussenkuehlung
MZK0222500	3+3	X	X

PER BOCCOLE DI RIDUZIONE VEDI PAG. TBL150-1-00
 FOR REDUCING BUSHINGS SEE PAGE TBL150-1-00
 FÜR REDUZIERBUCHSE SIEHE SEITE TBL150-1-00

MAZAK
 SQT 15-18M/MS/MY/MSY 12 STAZIONI - SQT200-250M/MS/MY/MSY 12 STAZIONI - SUPER QUADREX 200-250M
 PORTAUTENSILE ASSIALE PER BARENO 3+3 POSIZIONI Ø25mm
 Axial 3+3 position boring bar holder Ø25mm
 Axial Bohrhalter 3+3 Positionen Ø25mm

M.T. srl
 Via Casino Albini 480
 Tel. 0541/956034-957884
 Fax 0541/956341
 47842 S. GIOVANNI IN M. (RN)
 e-mail: mtma@mtmarchetti.com
 http://www.mtmarchetti.com



PAGINA MZK912-1-00

Subject to change without notice.

09/2022

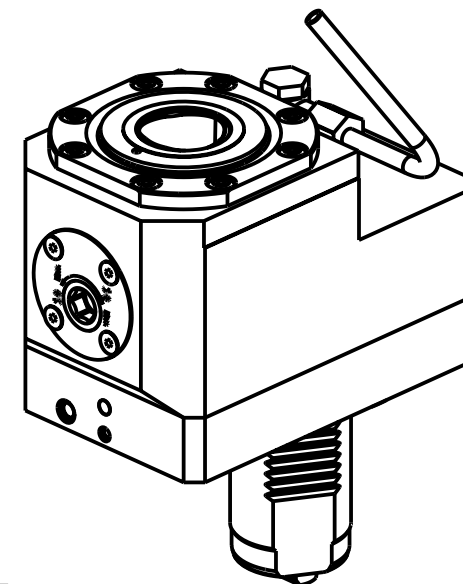
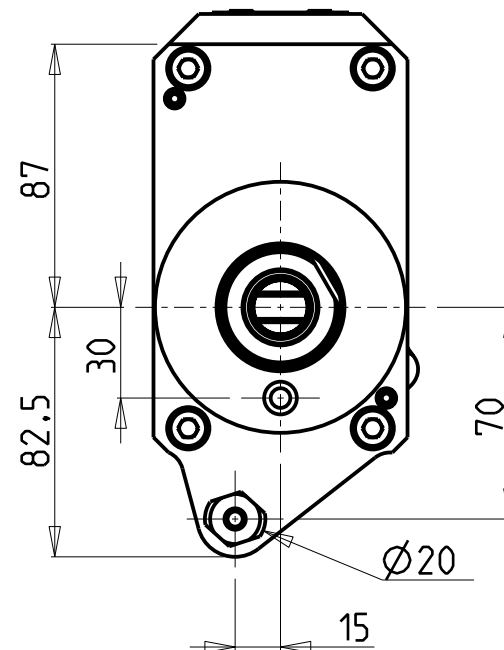
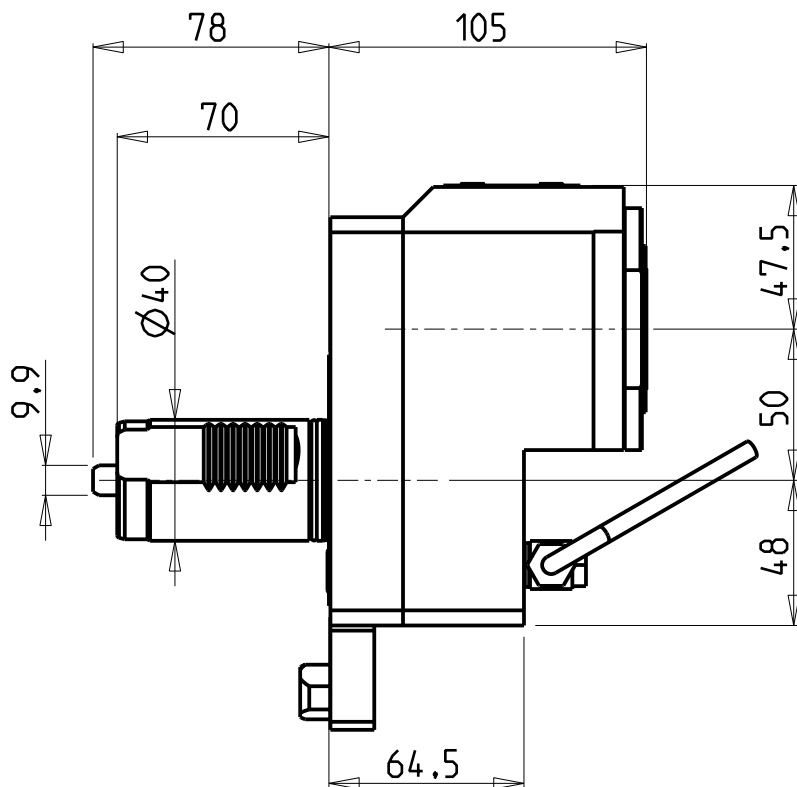
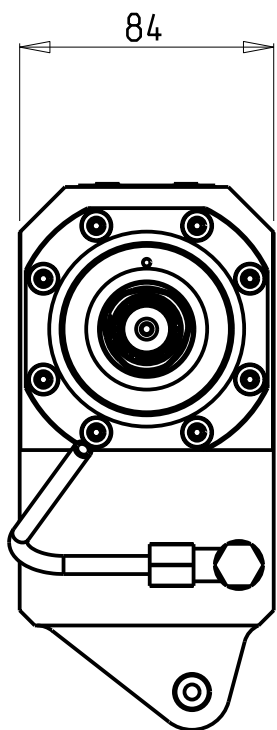

Cod. MT	TAGLIA Size Masse	I	RPM	Coppia Max Max Torque Max Drehmoment	Lubr.interna Coolant through Innenkuehlung	Lubr.esterna Ext. coolant Aussenkuehlung
MZK1210140	C4	1:1	6000	70Nm	-	X
MZK1210240	C4	1:1	6000	70Nm	P=70bar	X

MAZAK
 SQT 15-18M/MS/MY/MSY 12 STAZIONI - SQT200-250M/MS/MY/MSY 12 STAZIONI - QT NEXUS 200-250M/MS/MY/MSY 12 STAZIONI
 QT NEXUS 20011-25011 M/MS/MY/MSY 12 STAZIONI - SUPER QUADREX 200-250M - IVS200/300M

MODULO MOTORIZZATO RADIALE DISASSATO IN Z 50mm MT CAPTO
 Radial driven tool re-directed in Z by 50mm MT CAPTO
 Radial angetriebenes Werkzeug achsversetzt in Z um 50mm MT CAPTO

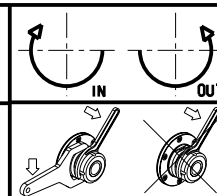

M.T. srl
 Via Casino Albini 480
 Tel. 0541/956034-957884
 Fax 0541/956341
 47842 S. GIOVANNI IN M. (RN)
 e-mail: mtma@mtmarchetti.com
 http://www.mtmarchetti.com



PAGINA MZK030-A-40

Subject to change without notice.

09/2022

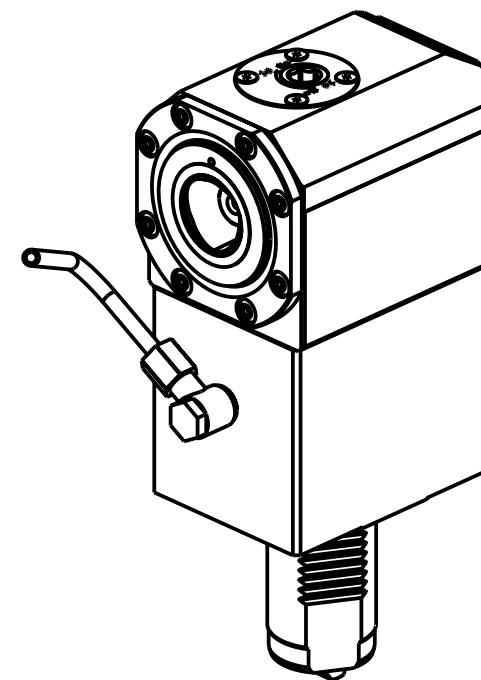
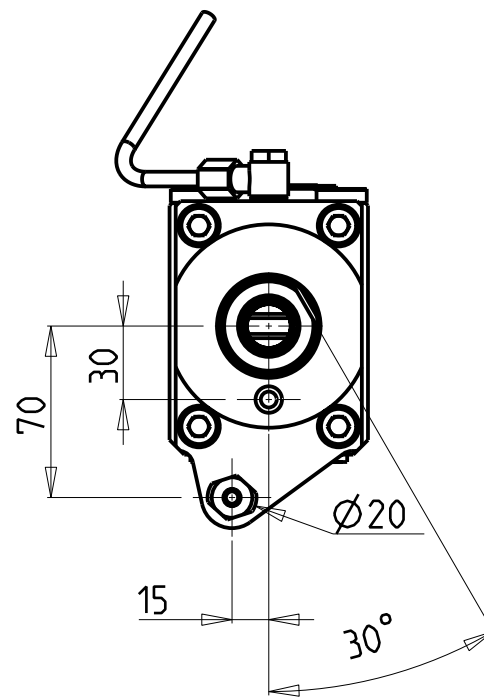
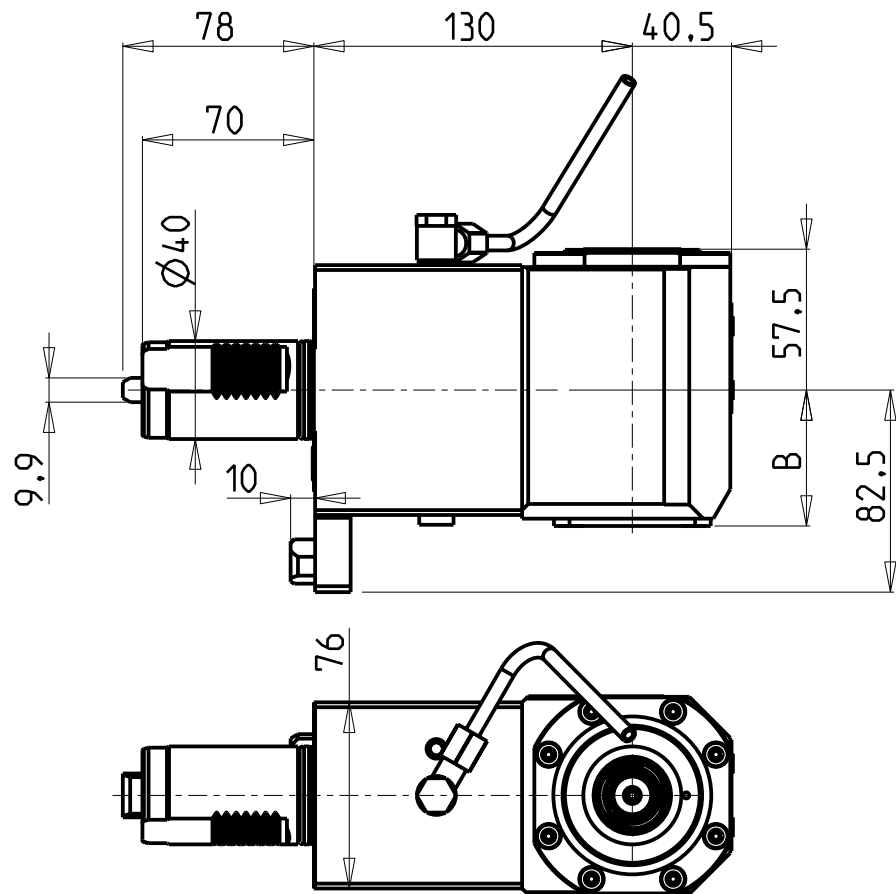

Cod. MT	TAGLIA Size Masse	I	RPM	Coppia Max Max Torque Max Drehmoment	Lubr.interna Coolant through Innenkuehlung	Lubr.esterna Ext. coolant Aussenkuehlung	B
MZK1200140	C4	1:1	6000	70Nm	-	X	55.5
MZK1200240	C4	1:1	6000	70Nm	P=70bar	X	68

MAZAK

SQT 15-18M/MS/MY/MSY 12 STAZIONI - SQT200-250M/MS/MY/MSY 12 STAZIONI - QT NEXUS 200-250M/MS/MY/MSY 12 STAZIONI
 QT NEXUS 20011-25011 M/MS/MY/MSY 12 STAZIONI - SUPER QUADREX 200-250M - IVS200/300M

MODULO MOTORIZZATO ASSIALE MT CAPTO

Axial driven tool MT CAPTO

Axial angetriebenes Werkzeug MT CAPTO

Subject to change without notice.

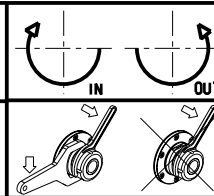

M.T. srl

Via Casino Albini 480
 Tel. 0541/956034-957884
 Fax 0541/956341

47842 S. GIOVANNI IN M. (RN)
 e-mail: mtma@mtmarchetti.com
 http://www.mtmarchetti.com



PAGINA MZK150-A-45

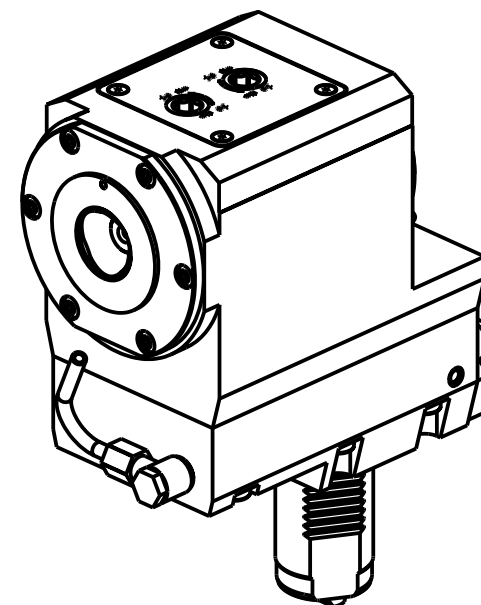
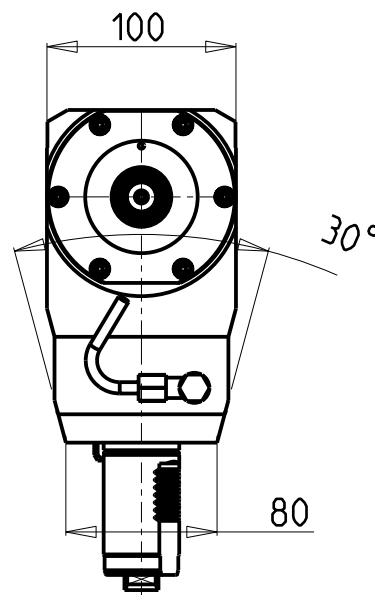
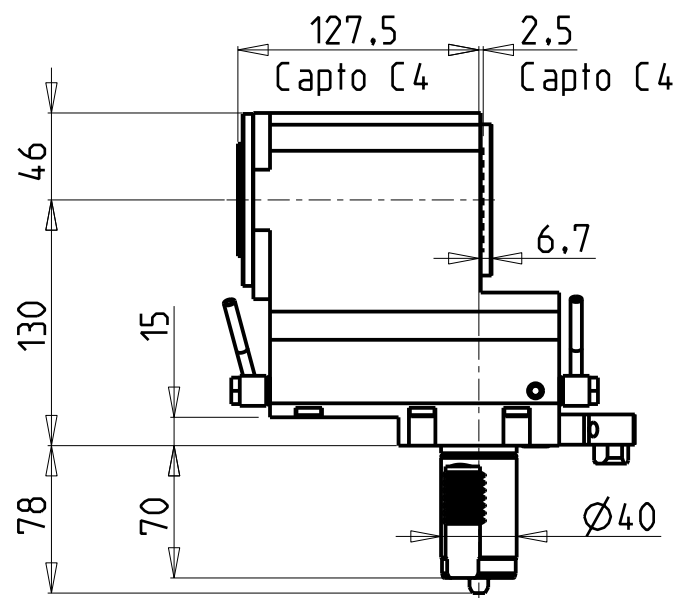
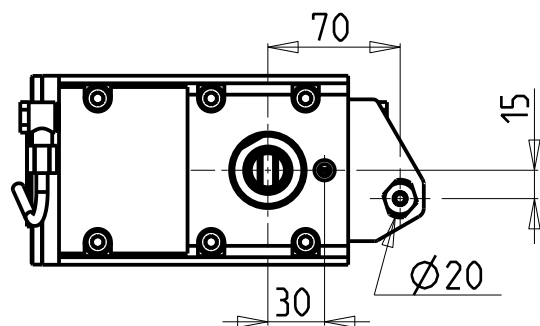

ATTENZIONE - ATTENTION - ACHTUNG

- Per lo smontaggio degli utensili utilizzare sempre la chiave di contrasto come indicato nel manuale d'uso.
- For disassembly of the tools use always the contrast key as mentioned in the user instructions.
- Fuer das Abmontieren der Werkzeuge immer den Gegenschlüssel benutzen wie in der Bedienungsanleitung erwaeht.

Cod. MT	TAGLIA Size Masse	I	RPM	Coppia Max Max Torque Max Drehmoment	Lubrificazione est. Ext. coolant Aussenkuehlung
MZK1190240	C4+C4	1:1	6000	70Nm	X

MAZAK
 SQT 15-18M/MS/MY/MSY 12 STAZIONI - SQT200-250M/MS/MY/MSY 12 STAZIONI - QT NEXUS 200-250M/MS/MY/MSY 12 STAZIONI
 QT NEXUS 20011-25011 M/MS/MY/MSY 12 STAZIONI - SUPER QUADREX 200-250M

MODULO MOTORIZZATO ASSIALE ARRETRATO BISPORGENTE MT CAPTO
 Axial opposite face rear-set driven tool MT CAPTO
 Axial angetriebenes Werkzeug zurueckversetzt halb vorspringend MT CAPTO

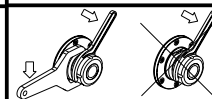

M.T. srl
 Via Casino Albini 480
 Tel. 0541/956034-957884
 Fax 0541/956341
 47842 S. GIOVANNI IN M. (RN)
 e-mail: mtma@mtmarchetti.com
 http://www.mtmarchetti.com



PAGINA MZK243-A-40

Subject to change without notice.

09/2022

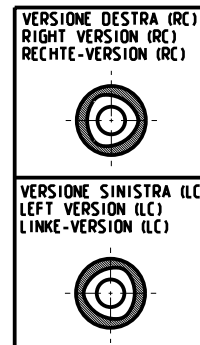
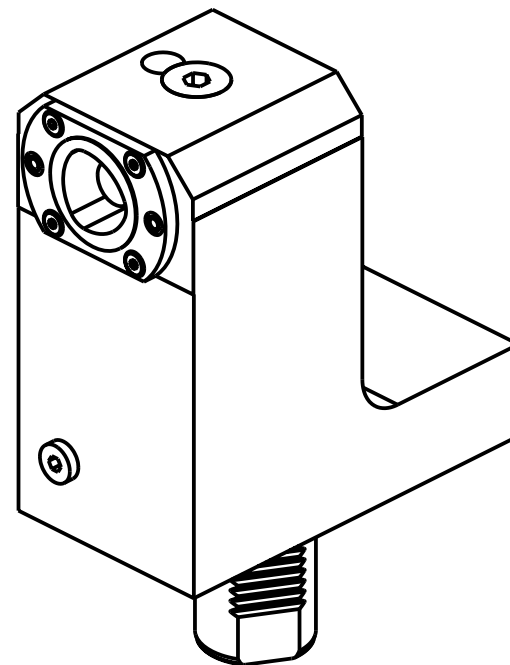
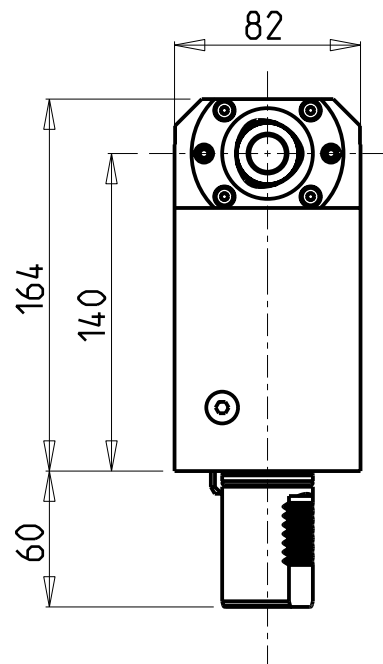
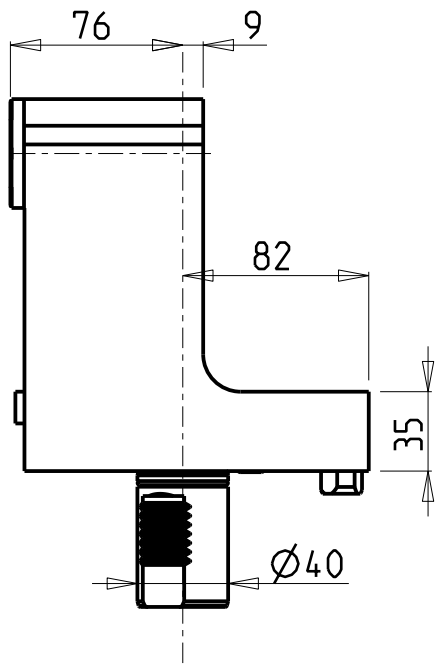
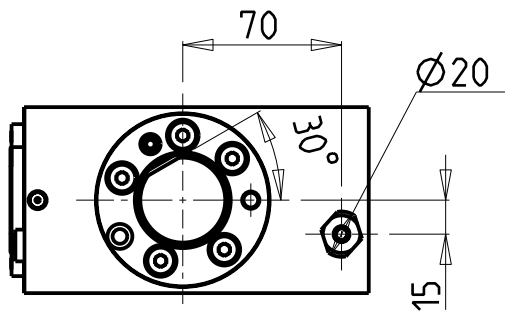

PER ORDINARE LA VERSIONE SX
 AGGIUNGERE "LC" AL CODICE IN TABELLA.
 ES: MZK1114010 DIVENTA MZK1114010LC

TO ORDER LEFT VERSION
 ADD A "LC" IN THE CODE-CHARTS.
 EXAMPLE: MZK1114010 BECOMES MZK1114010LC

UM DIE LINKE-VERSION ZU BESTELLEN, BEI DER
 ARTIKELBEZEICHNUNG "LC" HINZUFUEGEN.
 BEISPIEL: MZK1114010 WIRD DANN MZK1114010LC

Cod. MT	N°Utensili N°Tools N°Werkzeuge	Lubrificazione int. Coolant through Innenkuehlung	TAGLIA Size Masse
MZK1114010	1	X	C4

MAZAK
 SQT 15-18M/MS/MY/MSY 12 STAZIONI - SQT200-250M/MS/MY/MSY 12 STAZIONI - QT NEXUS 200-250M/MS/MY/MSY 12 STAZIONI
 QT NEXUS 20011-25011 M/MS/MY/MSY 12 STAZIONI - SUPER QUADREX 200-250M - 1VS200/300M

PORTAUTENSILE ASSIALE SINGOLO MT CAPTO
 Axial single static tool holder MT CAPTO
 Axial Single-Werkzeughalter MT CAPTO

Subject to change without notice.

M.T. srl
 Via Casino Albini 480
 Tel. 0541/956034-957884
 Fax 0541/956341
 47842 S. GIOVANNI IN M. (RN)
 e-mail: mtma@mtmarchetti.com
 http://www.mtmarchetti.com



PAGINA MZK550-A-40