

UPDATE
2016-2017

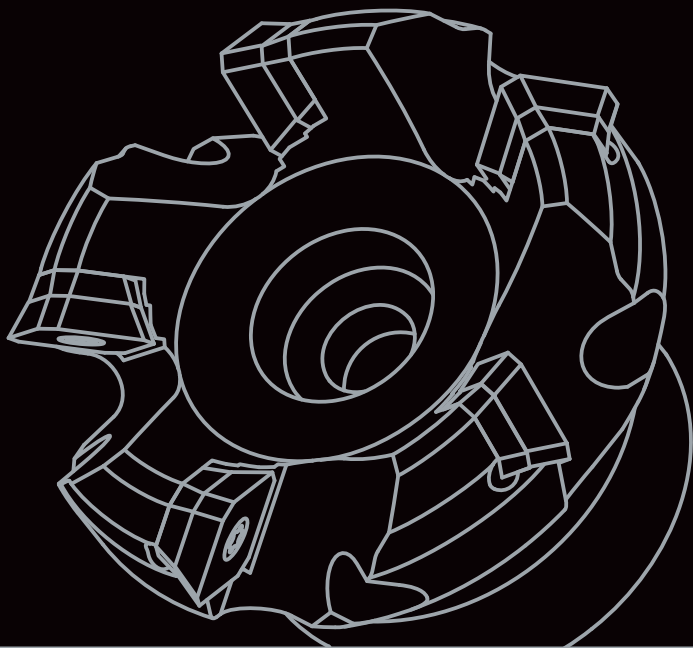

MIKOTOLS



Index

Turning	
POSITIVE	3
JC8005	11
Threading	
TPM	13
Drilling	
DRS	21
Milling	
DOUBLEHEX	31
DOUBLE4FACE	35
DOUBLE3GON	43
HF4PLUS	49
ADVANCED MILLING	53
ROUNDPLUS	59
OKTOPLUS	69
4FACEPLUS	75
SEET12 (ISO)	81
REKPLUS	85
APKT (ISO)	93

POSITIVE INSERTS SERIES

Think positive with Nikko!

ISO

P

M

K

N

S

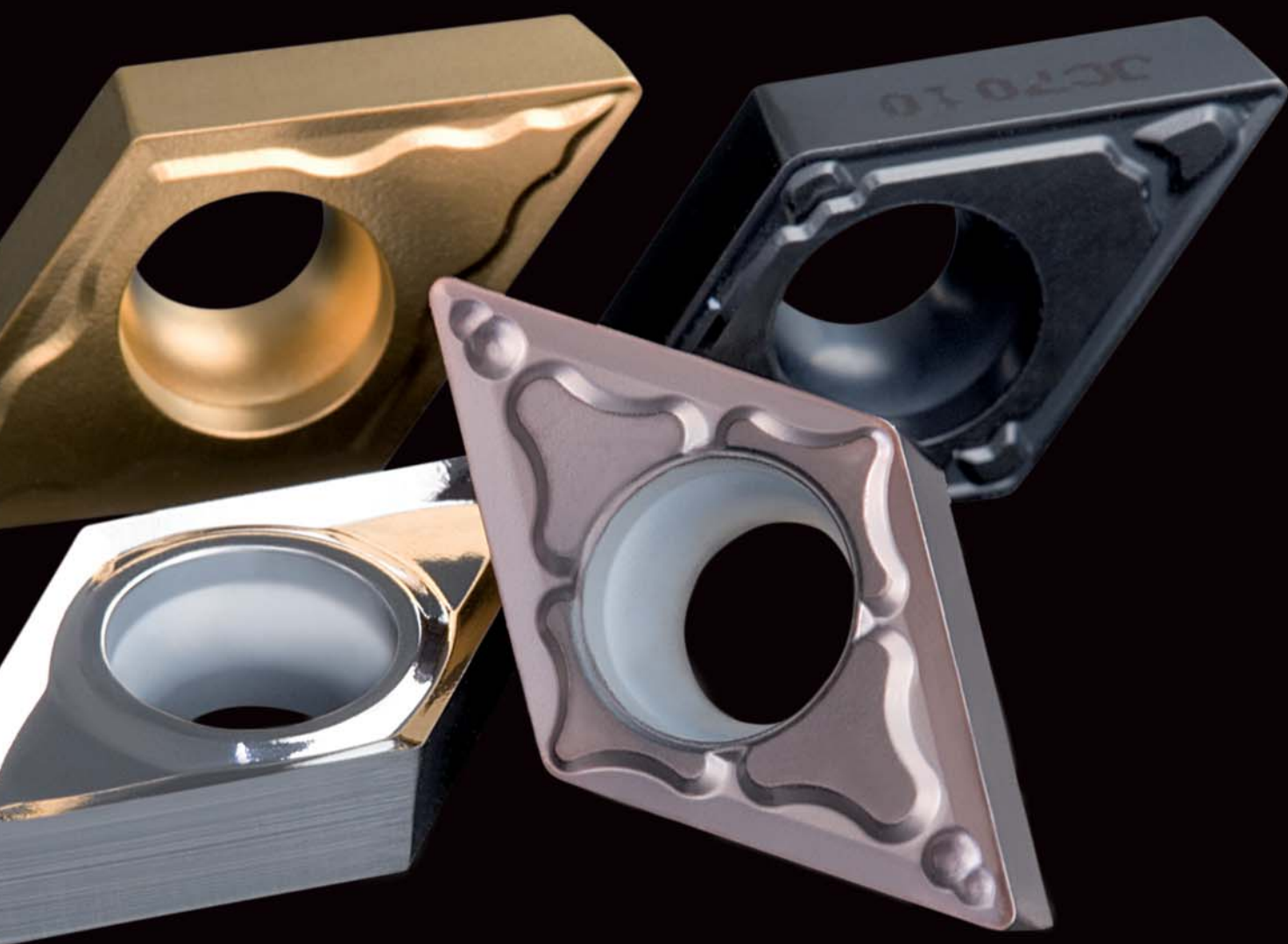

nikkoTOOLS

P M S

New PFU CHIPBREAKER

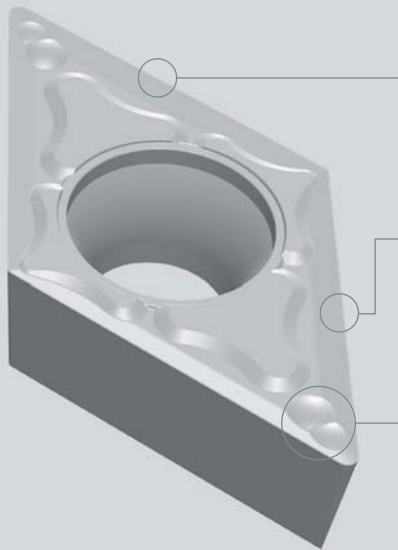

*** SHARP CUTTING EDGE**
Low cutting force and excellent surface finishing

🇮🇹 TAGLIENTE VIVO
Azione di taglio dolce ed ottima finitura superficiale

*** DOUBLE RAKE ANGLE**
Good balance between strength and sharpness of the cutting edge

🇮🇹 DOPPIO ANGOLO DI SPOGLIA
Buona combinazione tra taglienza e robustezza del filo tagliente

*** SPECIAL DOUBLE DOTS GEOMETRY**
Excellent chip control with low depth of cut

🇮🇹 GEOMETRIA A DOPPIO RILIEVO
Ottimo controllo truciolo a basse profondità di passata

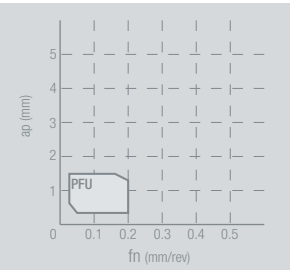

P M K

PMU CHIPBREAKER

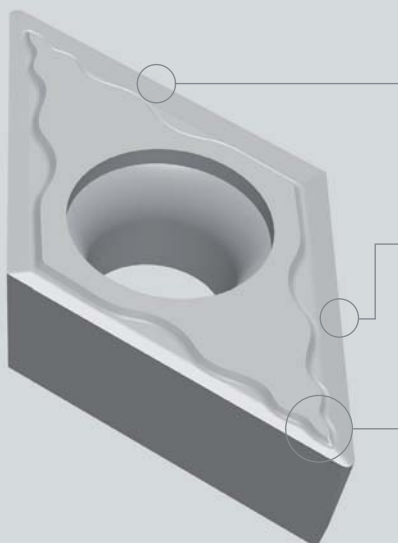

*** UNIVERSAL CHIPBREAKER**
First choice for general purpose

🇮🇹 TAGLIENTE UNIVERSALE
Prima scelta per impiego generico

*** DOUBLE RAKE ANGLE**
Good balance between strength and sharpness of the cutting edge

🇮🇹 DOPPIO ANGOLO DI SPOGLIA
Buona combinazione tra taglienza e robustezza del filo tagliente

*** WAVE GEOMETRY**
Excellent chip control even in case of variable depth of cut

🇮🇹 GEOMETRIA ONDULATA
Ottimo controllo truciolo anche con asportazioni variabili

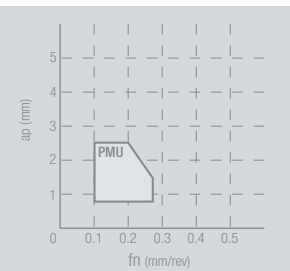

P **K**

New PRU CHIPBREAKER

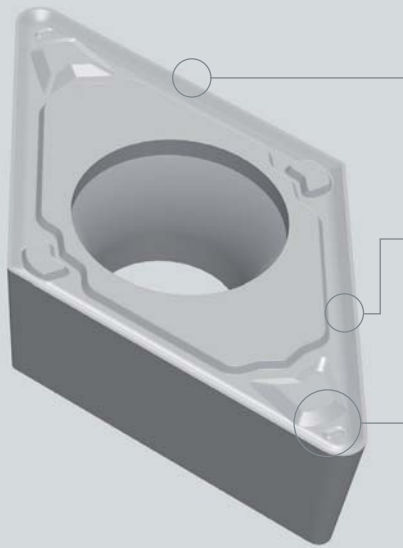

*** REINFORCED CUTTING EDGE**
First choice for difficult operations and interrupted cut

🇮🇹 TAGLIENTE RINFORZATO
Consigliato per lavorazioni gravose e taglio interrotto

*** WIDE AND SHALLOW GROOVES**
Low cutting force even at high deep of cut

🇮🇹 GOLE AMPIE E POCO PROFONDE
Basse forze di taglio anche ad elevate asportazioni

*** SPECIAL 3D GEOMETRY ON RADIUS ZONE**
Variable groove depth to reduce vibration

🇮🇹 GEOMETRIA 3D NELLA ZONA DEL RAGGIO
Gola con profondità variabile per ridurre le vibrazioni

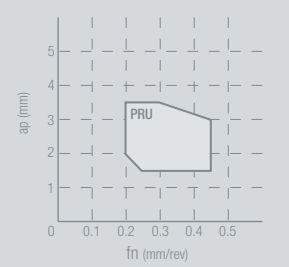

N

PMN CHIPBREAKER

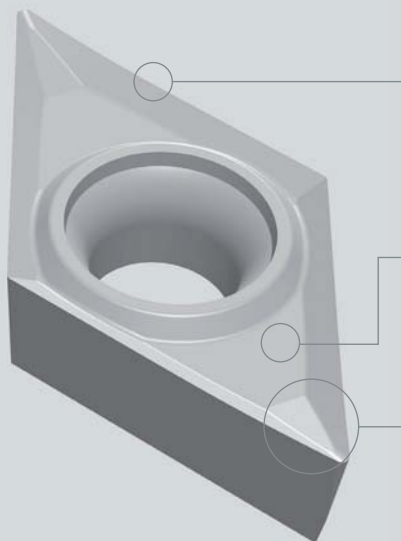

*** SHARP EDGE**
Excellent surface finishing without burrs

🇮🇹 TAGLIENTE AFFILATO E RETTIFICATO
Ottima finitura superficiale e riduzione delle bave

*** POLISHED SURFACE**
To reduce built-up edge

🇮🇹 SUPERFICIE LUCIDATA
Riduce la formazione del tagliante di riporto





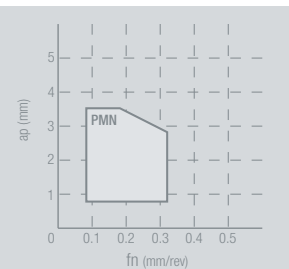

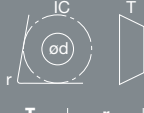

*** WIDE GROOVE**
Excellent chip evacuation at high cutting speed

🇮🇹 GOLA AMPIA
Ottimo deflusso del truciolo ad elevate velocità di taglio



POSITIVE INSERTS SERIES

INSERTS

DESCRIPTION					HT			HC					HW		
	IC	T	r	Ød	JU4015	JP5015	JP5025	JC7010	JC7020	JC8015	JC8025	JC9025	JU6010	JU6020	
PFU 	CCMT 060202-PFU	6.35	2.38	0.2	2.8	●	●	●			●	●	●		
	060204-PFU	6.35	2.38	0.4	2.8	●	●	●			●	●	●		
	CCMT 09T302-PFU	9.525	3.97	0.2	4.4	●	●	●			●	●	●		
	09T304-PFU	9.525	3.97	0.4	4.4	●	●	●			●	●	●		
PMU 	CCMT 060202-PMU	6.35	2.38	0.2	2.8	●		■	○		○	●	●		
	060204-PMU	6.35	2.38	0.4	2.8	●		●	○		●	●	●		
	060208-PMU	6.35	2.38	0.8	2.8	●		■	●		●	●	●		
	CCMT 09T302-PMU	9.525	3.97	0.2	4.4	●		■	○		●	●	●		
	09T304-PMU	9.525	3.97	0.4	4.4	●		●	●		●	●	●		
	09T308-PMU	9.525	3.97	0.8	4.4	●		●	●		●	●	●		
	CCMT 120404-PMU	12.7	4.76	0.4	5.5			■	●		●	●	●		
	120408-PMU	12.7	4.76	0.8	5.5			●	●		●	●	●		
PRU 	CCMT 09T304-PRU	9.525	3.97	0.4	4.4				●		●				
	09T308-PRU	9.525	3.97	0.8	4.4				●		●				
	CCMT 120408-PRU	12.7	4.76	0.8	5.5				●		●				
	120412-PRU	12.7	4.76	1.2	5.5				●		●				
PMN 	CCGX 060202-PMN	6.35	2.38	0.2	2.8								●		
	060204-PMN	6.35	2.38	0.4	2.8								●	●	
	060208-PMN	6.35	2.38	0.8	2.8								○	●	
	CCGX 09T302-PMN	9.525	3.97	0.2	4.4								●		
	09T304-PMN	9.525	3.97	0.4	4.4								●		
	09T308-PMN	9.525	3.97	0.8	4.4								○	●	
	CCGX 120402-PMN	12.7	4.76	0.2	5.5								●		
	120404-PMN	12.7	4.76	0.4	5.5								●	●	
PFU 	DCMT 070202-PFU	6.35	2.38	0.2	2.8	●	●	●			●	●	●		
	070204-PFU	6.35	2.38	0.4	2.8	●	●	●			●	●	●		
	DCMT 11T302-PFU	9.525	3.97	0.2	4.4	●	●	●			●	●	●		
	11T304-PFU	9.525	3.97	0.4	4.4	●	●	●			●	●	●		
PMU 	DCMT 070202-PMU	6.35	2.38	0.2	2.8	●			○		●	●	○		
	070204-PMU	6.35	2.38	0.4	2.8	●		●	●		●	●	●		
	070208-PMU	6.35	2.38	0.8	2.8	●		●	●		○	●	●		
	DCMT 11T302-PMU	9.525	3.97	0.2	4.4	●		■	○		●	●	●		
	11T304-PMU	9.525	3.97	0.4	4.4	●		●	●	○	●	●	●		
	11T308-PMU	9.525	3.97	0.8	4.4	●		●	●	○	●	●	●		
	DCMT 150404-PMU	12.7	4.76	0.4	5.6				○		●	●			
	150408-PMU	12.7	4.76	0.8	5.6				○		●	●	●		
PRU 	DCMT 11T304-PRU	9.525	3.97	0.4	4.4				●		●				
	11T308-PRU	9.525	3.97	0.8	4.4				●		●				

● stock standard; ○ non stock standard; ■ stock exhaustion

 finishing
  medium
  roughing

HC: coated carbide

HW: uncoated carbide

HT: Cermet

JP: PVD coating

JC: CVD coating

JU: uncoated

INSERTS

DESCRIPTION					HT			HC					HW		
	IC	T	r	Ød	JU4015	JP5015	JP5025	JC7010	JC7020	JC8015	JC8025	JC9025	JU6010	JU6020	
 PMN	DCGX 070202-PMN	6.35	2.38	0.2	2.8								●		
	070204-PMN	6.35	2.38	0.4	2.8								○	●	
	070208-PMN	6.35	2.38	0.8	2.8								○	●	
	DCGX 11T302-PMN	9.525	3.97	0.2	4.4									●	
	11T304-PMN	9.525	3.97	0.4	4.4									●	●
	11T308-PMN	9.525	3.97	0.8	4.4									○	●
 PMU	SCMT 09T304-PMU	9.525	3.97	0.4	4.4	●			●		●	●			
	09T308-PMU	9.525	3.97	0.8	4.4	●			●	●	●	●			
	SCMT 120404-PMU	12.7	4.76	0.4	5.5					●	●	●			
	120408-PMU	12.7	4.76	0.8	5.5					●	●	●			
 PRU	SCMT 09T308-PRU	9.525	3.97	0.8	4.4				●		●				
	SCMT 120408-PRU	12.7	4.76	0.8	5.5				●		●				
 PMN	SCGX 09T304-PMN	9.525	3.97	0.4	4.4								○	●	
	09T308-PMN	9.525	3.97	0.8	4.4								○	●	
	SCGX 120404-PMN	12.7	4.76	0.4	5.5								○	●	
	120408-PMN	12.7	4.76	0.8	5.5								○	●	
 PFU	TCMT 110202-PFU	6.35	2.38	0.2	2.8	●	●	●			●	●			
	110204-PFU	6.35	2.38	0.4	2.8	●	●	●			●	●			
 PMU	TCMT 090204-PMU	5.56	2.38	0.4	2.5	●		■	●		●	●			
	TCMT 110202-PMU	6.35	2.38	0.2	2.8	●		■	○		○	●			
	110204-PMU	6.35	2.38	0.4	2.8	●		■	●		●	●			
	110208-PMU	6.35	2.38	0.8	2.8	●		■	●		●	●			
	TCMT 16T304-PMU	9.525	3.97	0.4	4.4	●		●	●		●	●			
	16T308-PMU	9.525	3.97	0.8	4.4	●		●	●		●	●			
	16T312-PMU	9.525	3.97	1.2	4.4				○	○	○	●			
	TCMT 220408-PMU	12.7	4.76	0.8	5.6				○			●			
 PRU	TCMT 16T304-PRU	9.525	3.97	0.4	4.4				●		●				
	16T308-PRU	9.525	3.97	0.8	4.4				●		●				
 PMN	TCGX 090204-PMN	5.56	2.38	0.4	2.5								○	●	
	TCGX 110202-PMN	6.35	2.38	0.2	2.8								●		
	110204-PMN	6.35	2.38	0.4	2.8								○	●	
	110208-PMN	6.35	2.38	0.8	2.8								○	●	
	TCGX 16T302-PMN	9.525	3.97	0.2	4.4								●		
	16T304-PMN	9.525	3.97	0.4	4.4								○	●	
	16T308-PMN	9.525	3.97	0.8	4.4								○	●	
 PFU	VBMT 110304-PFU	6.35	3.18	0.4	2.8	●	●	●							
	VBMT 160404-PFU	9.525	4.76	0.4	4.4	●	●	●			●	●			
	160408-PFU	9.525	4.76	0.8	4.4	●	●	●			●	●			

● stock standard; ○ non stock standard; ■ stock exhaustion

finishing
 medium
 roughing

HC: coated carbide
 HW: uncoated carbide
 HT: Cermet

JP: PVD coating
 JC: CVD coating
 JU: uncoated

POSITIVE INSERTS SERIES

INSERTS

DESCRIPTION					HT		HC					HW		
	IC	T	r	Ød	JU4015	JP5015	JP5025	JC7010	JC7020	JC8015	JC8025	JC9025	JU6010	JU6020
 VBMT 160404-PMU	9.525	4.76	0.4	4.4	●		●	●		●	●	●		
	9.525	4.76	0.8	4.4	●		●	●		●	●	●		
 VBMT 160408-PRU	9.525	4.76	0.8	4.4				●						
 VCMT 110304-PMU	6.35	3.18	0.4	2.8	●		■	●		●	●	●		
	9.525	4.76	0.4	4.4	●		■	●		●	●	●		
	9.525	4.76	0.8	4.4	●		■	●		●	●	●		
 VCMT 160404-PRU	9.525	4.76	0.4	4.4				●						
	9.525	4.76	0.8	4.4				●						
 VCGX 110302-PMN	6.35	3.18	0.2	2.8									●	
	6.35	3.18	0.4	2.8									○	●
	6.35	3.18	0.8	2.8									●	●
	9.525	4.76	0.2	4.4									○	
	9.525	4.76	0.4	4.4									●	●
	9.525	4.76	0.8	4.4									○	●
	9.525	4.76	1.2	4.4										●
	12.7	5.56	3.0	5.6									●	●
 WCMT 12T304-PMU	9.525	3.97	0.4	4.4	●			●		●	●	●		
	9.525	3.97	0.8	4.4	●			●		●	●	●		

● stock standard; ○ non stock standard; ■ stock exhaustion



HC: coated carbide

HW: uncoated carbide

HT: Cermet

JP: PVD coating

JC: CVD coating

JU: uncoated

CHIPBREAKERS APPLICATION CHART

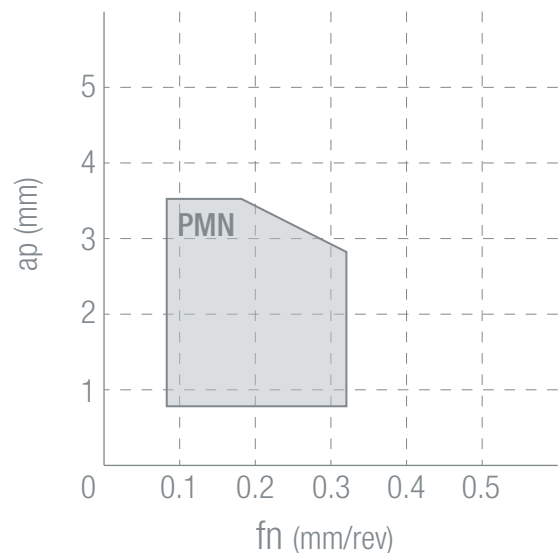
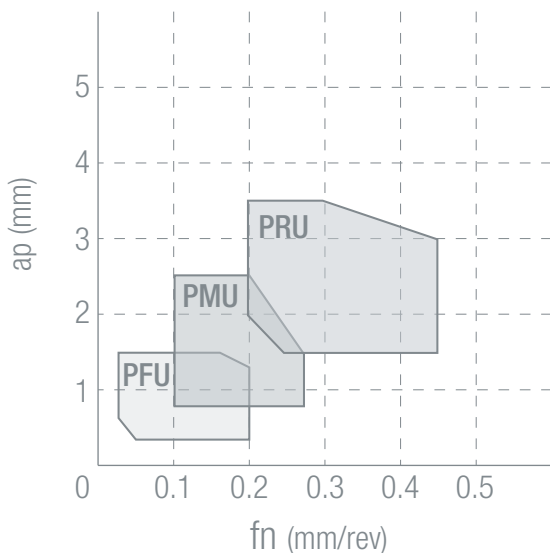



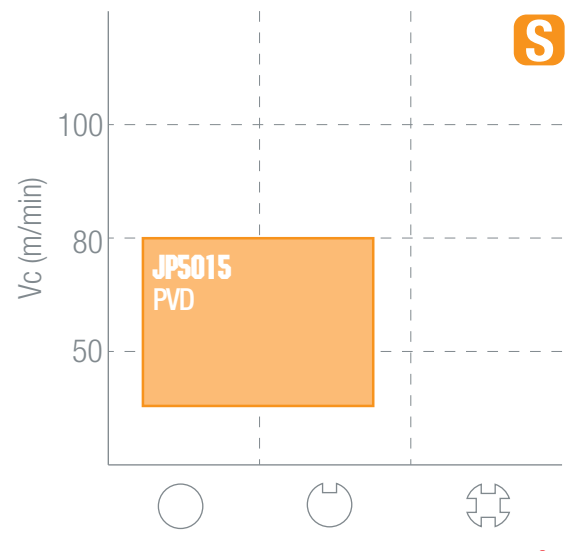
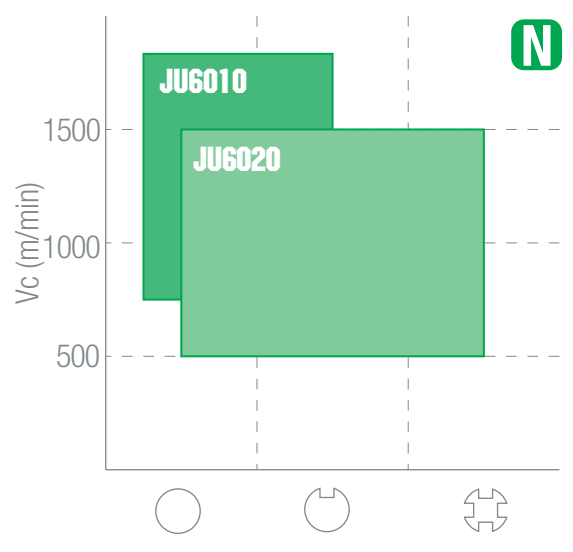
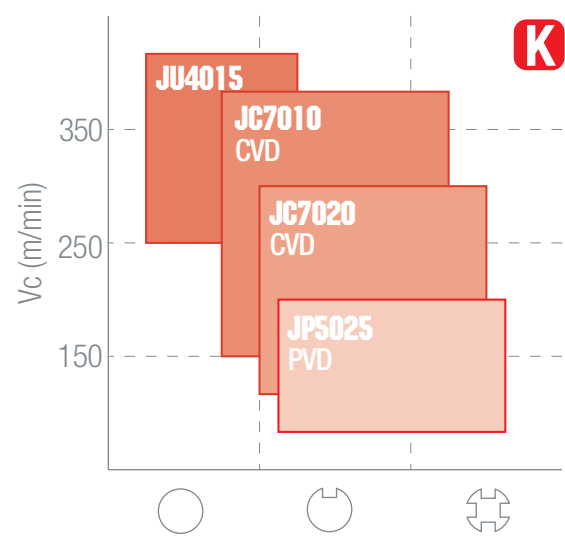
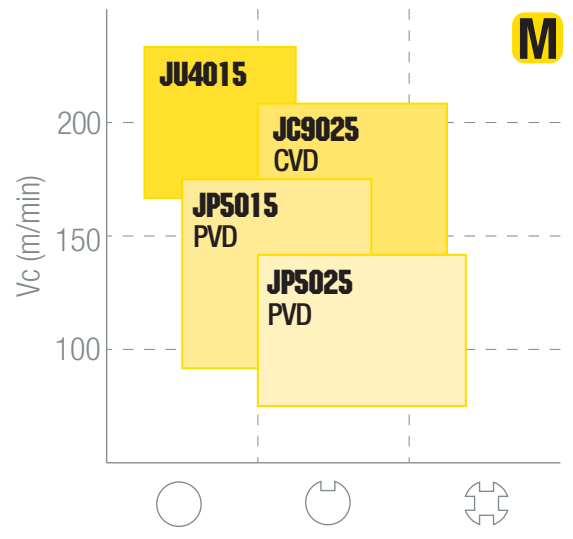
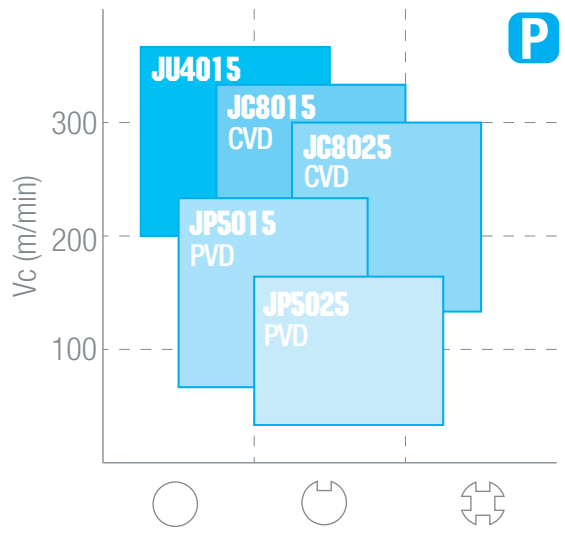

GRADES APPLICATION CHART

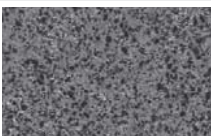
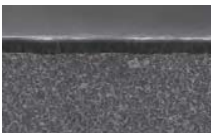
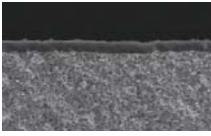

POSITIVE INSERTS SERIES

GRADES

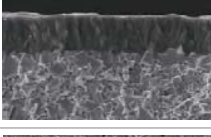
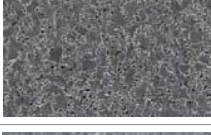
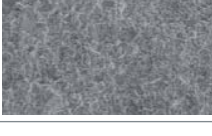
GRADE	ISO RANGE	MICROSTRUCTURE	DESCRIPTION
JU4015 UNCOATED CERMET	P M K		<ul style="list-style-type: none"> ✦ Uncoated cermet grade with good wear resistance. Finishing and semi-finishing on ISO P, M and K. Special post sintering treatment to improve cutting edge reliability. Excellent surface roughness. 🇮🇹 Grado cermet non rivestito con ottima resistenza all'usura per finitura e semi-finitura su materiali ISO P, M e K. Lo speciale trattamento dei taglienti consente di ottenere ottime rugosità superficiali.
JP5015 CARBIDE PVD	P M S		<ul style="list-style-type: none"> ✦ Sub micrograin carbide with PVD coating. New TiAlN coating family to improve wear and heat resistance for finishing and semi finishing on ISO P, M and S. 🇮🇹 Metallo duro sub-micrograna con rivestimento PVD a base TiAlN di nuova generazione con ottima resistenza all'usura ed al calore. Consigliato per lavorazioni di finitura e semi-finitura su materiali ISO P, M e S.
JP5025 CARBIDE PVD	P M K		<ul style="list-style-type: none"> ✦ Extremely tough sub micrograne carbide with TiAlN base PVD. General purpose on ISO P, M and K at moderate cutting speed. 🇮🇹 Metallo duro sub-micrograna estremamente tenace con rivestimento PVD a base TiAlN. Consigliato per lavorazioni generiche e velocità di taglio moderate su materiali ISO P, M e K.
JC7010 CARBIDE CVD	K		<ul style="list-style-type: none"> ✦ Micro grain carbide with thick MT-CVD (TiCN+Al₂O₃) coating. Special surface treatment to improve reliability. Grey and nodular cast iron machining on continuous and interrupted cut. 🇮🇹 Metallo duro micrograna con rivestimento MT-CVD (TiCN+Al₂O₃) di elevato spessore e speciale trattamento superficiale. Indicato per lavorazioni ISO K sia in condizioni di taglio continuo che interrotto.
JC7020 CARBIDE CVD	K		<ul style="list-style-type: none"> ✦ Micro grain carbide with high toughness and thick MT-CVD (TiCN+Al₂O₃) coating. First choice for cast iron difficult machining. 🇮🇹 Metallo duro micrograna ad elevata tenacità con rivestimento MT-CVD (TiCN+Al₂O₃) di elevato spessore. Consigliato per lavorazioni particolarmente gravose di ghisa grigia e sferoidale (ISO K).
JC8015 CARBIDE CVD	P		<ul style="list-style-type: none"> ✦ Carbide grade with high wear resistance MT-CVD (TiCN+Al₂O₃+TiN). High cutting speed and stable machining for free cutting steel and alloy steel. 🇮🇹 Metallo duro estremamente resistente all'usura con rivestimento MT-CVD (TiCN+Al₂O₃+TiN). Applicabile su acciaio al carbonio ed acciaio legato (ISO P) in condizioni stabili e velocità di taglio elevate.
JC8025 CARBIDE CVD	P		<ul style="list-style-type: none"> ✦ Carbide substrate with good toughness. MT-CVD (TiCN+Al₂O₃+TiN) coating. Suitable for general purpose on ISO P even on interrupted cut. 🇮🇹 Substrato di metallo duro con ottima tenacità abbinato ad un rivestimento MT-CVD (TiCN+Al₂O₃+TiN). Consigliato per uso generico su materiali ISO P anche in condizioni di taglio interrotto.
JC9025 CARBIDE CVD	M		<ul style="list-style-type: none"> ✦ Tough carbide substrate with thin MT-CVD (TiCN+TiN) coating. Medium roughing application on stainless steel (ISO M) even on light interrupted cut. 🇮🇹 Substrato di metallo duro tenace con sottile rivestimento MT-CVD (TiCN+TiN) e speciale trattamento di spazzolatura. Consigliato per semi-sgrossatura di acciaio inossidabile.
JU6010 UNCOATED CARBIDE	N		<ul style="list-style-type: none"> ✦ Hard micrograin carbide for an outstanding wear resistance. First choice for non-ferrous material (ISO N). High cutting speed and stable machining. 🇮🇹 Metallo duro micrograna ad elevata durezza per garantire un'eccezionale resistenza all'usura. Consigliato per lavorazione di materiali non ferrosi (ISO N) ad elevata velocità e condizioni stabili.
JU6020 UNCOATED CARBIDE	N		<ul style="list-style-type: none"> ✦ Fine grain carbide for non-ferrous material (ISO N). From finishing to roughing even in light interrupted cut. 🇮🇹 Metallo duro a grana fine per lavorazione generica di materiali non ferrosi (ISO N) dalla finitura alla sgrossatura anche in condizioni di taglio leggermente interrotto.

JC8005 SERIES

Simply the best for high speed turning of steel.

ISO



P

- carbide P05
- CVD coating





nikkoTOOLS

JC8005 SERIES

DESCRIPTION			JC8005
NUP		CNMG 120404-NUP	●
		120408-NUP	●
		120412-NUP	●
		120416-NUP	●
NUP		DNMG 150604-NUP	●
		150608-NUP	●
		150612-NUP	●
NUP		SNMG 120408-NUP	
		120412-NUP	

● stock standard

DESCRIPTION			JC8005
NUP		TNMG 160404-NUP	●
		160408-NUP	●
		160412-NUP	●
NUP		VNMG 160404-NUP	
		160408-NUP	
NUP		WNMG 080404-NUP	●
		080408-NUP	●
		080412-NUP	●
		080416-NUP	●

● stock standard

GRADE APPLICATION CHART

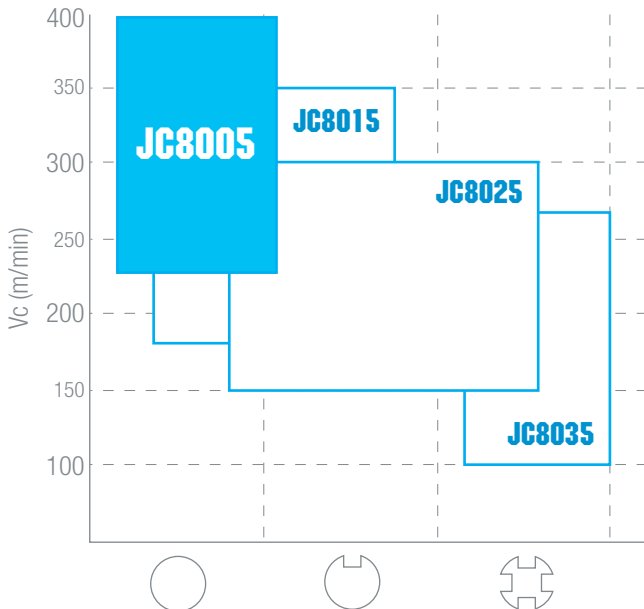

CHIPBREAKER APPLICATION CHART

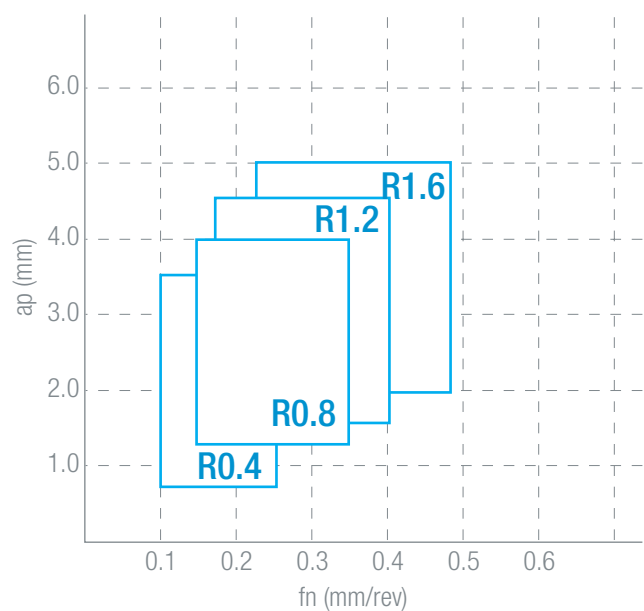

TPM THREADING SERIES

Universal geometry for perfect chip control.

ISO



- METRIC
- WHITWORTH
- UN
- NPT
- BSPT

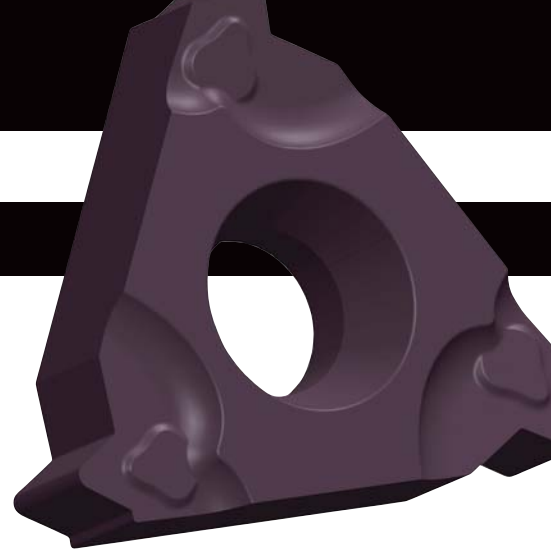

TPM THREADING SERIES

Universal geometry for perfect chip control.



- Thanks to an innovating moulding process (Threading Precision Moulding), the new TPM geometry meets the accuracy standards of more expensive ground inserts.
- The chipbreaker has been optimized in order to ensure a perfect chip control on a wide range of materials.
- Thread standard and pitch are clearly marked on each insert.



- Grazie ad un'accurata procedura di stampaggio, la nuova geometria sinterizzata TPM (Threading Precision Moulding) è in grado di garantire taglienza e precisione paragonabili alle più costose tipologie rettificate.
- La perfetta conformazione del rompitruciolo assicura un controllo ottimale su una grande varietà di materiali.
- Tipologia di filettatura e passo sono chiaramente indicati su ogni inserto.



- Dank eines innovativen Formverfahren (Threading Precision Moulding), erfüllt die TPM Geometrie Genauigkeitsstandards teurer Wendeschneidplatten.
- Der Spanbrecher wurde optimiert, um eine perfekte Kontrolle über die Späne auf einer breiten Palette von Materialien zu gewährleisten.
- Gewindestandards und Steigungen sind auf jedem Einsatz markiert.



- Grace à un innovant procédé de moulage, la nouvelle géométrie TPM (Threading Precision Moulding) garantit une précision de coupe équivalente à celle des plaquettes affûtées, à un prix nettement plus bas.
- La forme idéale du brise-copeaux maîtrise parfaitement les copeaux dans une grande variété de matières.
- Le filet et le pas sont marqués sur chaque plaquette.







- Gracias a un proceso de moldeo preciso, la nueva geometría TPM sinterizada (Threading Precision Moulding) asegura afilado y precisión comparables a las más cara tipologia rectificada.
- La conformación ideal del rompevirutas asegura un óptimo control y una amplia variedad de materiales.
- El tipo de rosca y de paso están claramente marcados en cada placa.



- Благодаря передовой технологии изготовления (Threading Precision Moulding), новая TPM геометрия в состоянии обеспечить точность сравнимую с пластинами изготовленных путём шлифования.
- Усовершенствованный стружколом обеспечивает высокий уровень контроля стружки для широкой гаммы материалов.
- Тип и шаг резьбы указаны на каждой пластине.





INSERTS

		16ER (FULL PROFILE EXTERNAL)						METRIC							
TPM		DESCRIPTION					No. OF PASSES	HC							
				IC	T	r		Ød	JP5125						
		16ER 100ISO-TPM	1.00	9.525	3.47	0.14	4.0	5÷8	●						
		125ISO-TPM	1.25	9.525	3.47	0.18	4.0	6÷9	●						
		150ISO-TPM	1.50	9.525	3.47	0.22	4.0	6÷9	●						
		175ISO-TPM	1.75	9.525	3.47	0.25	4.0	8÷11	●						
		200ISO-TPM	2.00	9.525	3.47	0.29	4.0	8÷11	●						
		250ISO-TPM	2.50	9.525	3.47	0.36	4.0	10÷13	●						
		300ISO-TPM	3.00	9.525	3.47	0.43	4.0	12÷15	●						

● stock standard

HC: coated carbide

JP: PVD coating

		11/16IR (FULL PROFILE INTERNAL)						METRIC							
TPM		DESCRIPTION					No. OF PASSES	HC							
				IC	T	r		Ød	JP5125						
		11IR 100ISO-TPM	1.00	6.35	3.18	0.07	3.0	5÷8	●						
		125ISO-TPM	1.25	6.35	3.18	0.09	3.0	6÷9	★						
		150ISO-TPM	1.50	6.35	3.18	0.11	3.0	6÷9	●						
		175ISO-TPM	1.75	6.35	3.18	0.13	3.0	8÷11	★						
		200ISO-TPM	2.00	6.35	3.18	0.15	3.0	8÷11	●						
		16IR 100ISO-TPM	1.00	9.525	3.47	0.07	4.0	5÷8	●						
		125ISO-TPM	1.25	9.525	3.47	0.09	4.0	6÷9	●						
		150ISO-TPM	1.50	9.525	3.47	0.11	4.0	6÷9	●						
		175ISO-TPM	1.75	9.525	3.47	0.13	4.0	8÷11	●						
		200ISO-TPM	2.00	9.525	3.47	0.15	4.0	8÷11	●						
		250ISO-TPM	2.50	9.525	3.47	0.18	4.0	10÷13	●						
		300ISO-TPM	3.00	9.525	3.47	0.22	4.0	12÷15	●						

● stock standard; ★ upcoming introduction

HC: coated carbide

JP: PVD coating

TPM THREADING SERIES

INSERTS

DESCRIPTION								No. OF PASSES	HC						
		TPI	IC	T	r	Ød	JP5125								
TPM		16ER 19W-TPM	19	9.525	3.47	0.17	4.0	6÷9	●						
		14W-TPM	14	9.525	3.47	0.24	4.0	8÷11	●						
		11W-TPM	11	9.525	3.47	0.30	4.0	9÷12	●						

● stock standard

HC: coated carbide

JP: PVD coating

DESCRIPTION								No. OF PASSES	HC						
		TPI	IC	T	r	Ød	JP5125								
TPM		16IR 19W-TPM	19	9.525	3.47	0.17	4.0	6÷9	●						
		14W-TPM	14	9.525	3.47	0.24	4.0	8÷11	●						
		11W-TPM	11	9.525	3.47	0.30	4.0	9÷12	●						

● stock standard



HC: coated carbide

JP: PVD coating



BOX 5 PCS.

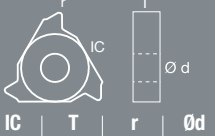

INSERTS

DESCRIPTION							No. OF PASSES	HC							
			IC	T	r	Ød		JP5125							
TPM		16ER 24UN-TPM	24 TPI	9.525	3.47	0.13	4.0	5÷8	●						
		20UN-TPM	20 TPI	9.525	3.47	0.16	4.0	6÷9	●						
		18UN-TPM	18 TPI	9.525	3.47	0.18	4.0	6÷9	●						
		16UN-TPM	16 TPI	9.525	3.47	0.22	4.0	7÷10	●						
		14UN-TPM	14 TPI	9.525	3.47	0.22	4.0	8÷11	●						
		12UN-TPM	12 TPI	9.525	3.47	0.26	4.0	8÷11	●						
		08UN-TPM	8 TPI	9.525	3.47	0.38	4.0	12÷15	●						

● stock standard

HC: coated carbide

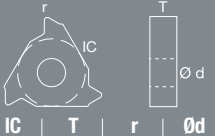
JP: PVD coating

DESCRIPTION							No. OF PASSES	HC							
			IC	T	r	Ød		JP5125							
TPM		16IR 24UN-TPM	24 TPI	9.525	3.47	0.07	4.0	5÷8	●						
		20UN-TPM	20 TPI	9.525	3.47	0.09	4.0	6÷9	●						
		18UN-TPM	18 TPI	9.525	3.47	0.10	4.0	6÷9	●						
		16UN-TPM	16 TPI	9.525	3.47	0.13	4.0	7÷10	●						
		14UN-TPM	14 TPI	9.525	3.47	0.14	4.0	8÷11	●						
		12UN-TPM	12 TPI	9.525	3.47	0.15	4.0	8÷11	●						
		08UN-TPM	8 TPI	9.525	3.47	0.25	4.0	12÷15	●						

● stock standard

HC: coated carbide

JP: PVD coating



BOX 5 PCS.

TPM THREADING SERIES

INSERTS

DESCRIPTION								No. OF PASSES	HC						
		TPI	IC	T	r	Ød	JP5125								
TPM		16ER 18NPT-TPM	18	9.525	3.47	0.06	4.0	8÷11	●						
		14NPT-TPM	14	9.525	3.47	0.07	4.0	10÷13	●						
		11.5NPT-TPM	11.5	9.525	3.47	0.07	4.0	12÷15	●						

● stock standard

HC: coated carbide

JP: PVD coating

DESCRIPTION								No. OF PASSES	HC						
		TPI	IC	T	r	Ød	JP5125								
TPM		16IR 18NPT-TPM	18	9.525	3.47	0.06	4.0	8÷11	●						
		14NPT-TPM	14	9.525	3.47	0.08	4.0	10÷13	●						
		11.5NPT-TPM	11.5	9.525	3.47	0.09	4.0	12÷15	●						

● stock standard

HC: coated carbide

JP: PVD coating





BOX 5 PCS.

INSERTS

16ER (FULL PROFILE EXTERNAL) TAPERED PIPE (BSPT)



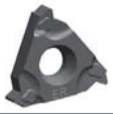

TPM	DESCRIPTION						No. OF PASSES	HC						
			IC	T	r	Ød		JP5125						
	16ER 28BSPT-TPM	28 TPI	9.525	3.47	0.10	4.0	5÷8	●						
	16ER 19BSPT-TPM	19 TPI	9.525	3.47	0.16	4.0	6÷9	●						
	16ER 14BSPT-TPM	14 TPI	9.525	3.47	0.24	4.0	9÷12	●						
	16ER 11BSPT-TPM	11 TPI	9.525	3.47	0.30	4.0	12÷15	●						

● stock standard HC: coated carbide JP: PVD coating

16IR (FULL PROFILE INTERNAL) TAPERED PIPE (BSPT)



TPM	DESCRIPTION						No. OF PASSES	HC					
			IC	T	r	Ød		JP5125					
	16IR 28BSPT-TPM	28 TPI	9.525	3.47	0.10	4.0	5÷8	●					
	16IR 19BSPT-TPM	19 TPI	9.525	3.47	0.16	4.0	6÷9	●					
	16IR 14BSPT-TPM	14 TPI	9.525	3.47	0.24	4.0	9÷12	●					
	16IR 11BSPT-TPM	11 TPI	9.525	3.47	0.30	4.0	12÷15	●					

● stock standard HC: coated carbide JP: PVD coating



BOX 5 PCS.

TPM THREADING SERIES

GRADE APPLICATION CHART

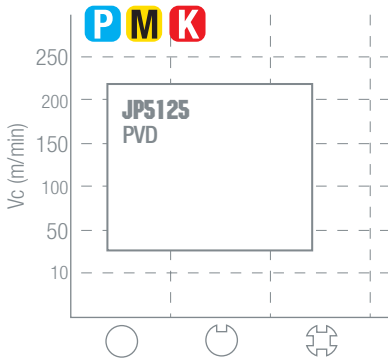

CUTTING SPEED (Vc m/min)

Gr.	MATERIAL			JP5125
P1	Free cutting steel and structural steel	Rm < 500 N/mm ²	(9SMn28 / 1.0715 / AVP)	160 ÷ 200
P2	Carbon steel and low alloy steel	Rm 500-700 N/mm ²	(C40 / 1.0511)	140 ÷ 180
P3	Medium alloy steel and heat treated steel	Rm 600-800 N/mm ²	(42CrMo4 / 1.7225)	100 ÷ 160
P4	High alloy steel	Rm 800-1000 N/mm ²	(100Cr6 / 1.3505)	80 ÷ 140
P5	Tool steel	Rm 900-1200 N/mm ²	(X210Cr12 / 1.2080 / K100)	80 ÷ 120
P6	High tensile strength steel	Rm 1200-1600 N/mm ²	(X2NiCrMo18.9.5 / 1.6358 / W720)	50 ÷ 80
M1	Ferritic stainless steel	Rm 400-700 N/mm ²	(X40Cr13 / 1.4034 / AISI420)	100 ÷ 140
M2	Austenitic stainless steel (good machinability)	Rm 500-750 N/mm ²	(X5CrNi18.10 / 1.4301 / AISI304)	80 ÷ 120
M3	Austenitic stainless steel (medium machinability)	Rm 550-850 N/mm ²	(X2CrNiMo18.12 / 1.4435 / AISI316L)	80 ÷ 100
M4	Martensitic stainless steel	Rm 650-950 N/mm ²	(X2CrNiMoN25.7.4 / 1.4410 / Super Duplex)	60 ÷ 80
M5	PH stainless steel	Rm 800-1250 N/mm ²	(X5CrNiNb16.4 / 1.4542 / 17-4PH)	40 ÷ 60
K1	Grey cast iron	HB 150-250	(GG-25 / 0.6025)	100 ÷ 140
K2	Nodular cast iron	HB 150-350	(GGG-50 / 0.7050)	80 ÷ 100
K3	Austenitic cast iron	HB 120-260	(GGL-NiCr20.2 / 0.6660)	60 ÷ 80
K4	ADI cast iron	HB 250-500	(GJS-1000-5 / ADI 1000)	40 ÷ 60

DRS DRILLING SYSTEM

High-performance solution for universal use.

ISO

P

M

K

N

S

- 2xD
- 3xD
- 4xD

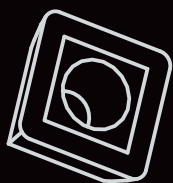

4 edges

nixkoTOOLS

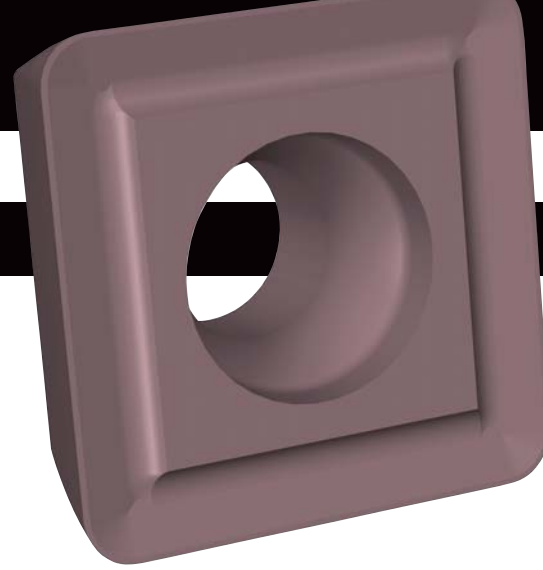

DRS DRILLING SYSTEM

High-performance solution for universal use.



- High-performance drilling system featuring 4-edged SPMX inserts, for enhanced versatility and massive cost reduction.
- Cutting geometry optimized to efficiently machine ISO P, M and K material classes, allowing high process stability and reduced cutting forces.
- JP5625 micrograin carbide for universal application, JP9635 for ISO M and ISO S specific applications, JU6520 combined to lapped and ground AL geometry for non ferrous materials ISO N.



- Sistema di foratura ad alte prestazioni estremamente versatile ed economico grazie all'inserto a 4 taglienti SPMX.
- Geometria ottimizzata per impiego generico su materiali ISO P, M e K in grado di garantire eccezionale stabilità e ridotti sforzi di taglio.
- JP5625 metallo duro micrograna per impiego universale, JP9635 per applicazioni specifiche su ISO M ed ISO S, JU6520 combinato con la geometria rettificata e lappata AL per materiali non ferrosi ISO N.



- Hochleistungs-Bohrsystem mit 4 schneidigen SPMX Wendeschneidplatten für verbesserte Vielseitigkeit und massiven Kostenreduktion.
- Optimierte Geometrie für den allgemeinen Gebrauch von Materialien ISO P, M und K, so dass eine hohe Prozessstabilität und reduzierte Schnittkraft ermöglicht wird.
- JP5625 Feinstkornhartmetall für den universellen Einsatz, JP9635 für spezifische Anwendungen von ISO M und ISO S, JU6520 mit angepasster geschliffener Geometrie AL für Nicht Eisen Materialien ISO N.



- Système de perçage haute-performance, extrêmement flexible et économique, grâce aux plaquettes à 4 arêtes SPMX.
- Géométrie de coupe optimisée pour utilisation sur matières ISO P, M et K, qui assure une excellente stabilité et un réduit effort de coupe.
- JP5625 carbure micro-grain pour utilisation universelle, JP9635 pour matières ISO M et ISO S, JU6520 avec géométrie rectifiée et polie AL pour matières ISO N.



- Sistema de taladrado extremadamente versátil, de alto rendimiento y económico gracias a la placa con 4 filos de corte SPMX.
- Geometría optimizada para el uso general en materiales ISO P, M y K que garantiza una estabilidad excepcional y la reducción de los esfuerzos de corte.
- JP5625 metal duro micrograno para uso universal, JP9635 para aplicaciones específicas en ISO M e ISO S, JU6520 combinado con la geometría rectificada y lappada AL para materiales no ferrosos ISO.



- Высокопроизводительная система сверления с 4мя режущими кромками с пластинами SPMX, обеспечивает существенное сокращение затрат.
- Режущая геометрия оптимизирована для обработки материалов групп ISO P, M и K и обеспечивает высокую стабильность обработки и малые режущие усилия.
- JP5625 мелкозернистый твердый сплав для общего применения, JP9635 предназначен для ISO M и ISO S, JU6520 комбинация формы полученной шлифованием и полировкой предназначен для Al других цветных металлов ISO N.

INSERTS

DESCRIPTION						HC		HW							
		IC	T	r	Ød	JP5625	JP9635	JU6520							
GP		SPMX 050204-GP	5.00	2.38	0.4	2.50	●	●							
		060204-GP	6.00	2.38	0.4	2.80	●	●							
		07T308-GP	7.94	3.97	0.8	2.80	●	●							
		090408-GP	9.80	4.30	0.8	4.10	●	●							
		110408-GP	11.50	4.76	0.8	4.40	●	●							
		140512-GP	14.30	5.20	1.2	5.50	●	●							
AL		SPGX 050204-AL	5.00	2.38	0.4	2.50			★						
		060204-AL	6.00	2.38	0.4	2.80			★						
		07T308-AL	7.94	3.97	0.8	2.80			★						
		090408-AL	9.80	4.30	0.8	4.10			★						
		110408-AL	11.50	4.76	0.8	4.40			★						
		140512-AL	14.30	5.20	1.2	5.50			★						

● stock standard; ★ upcoming introduction

HC: coated carbide JP: PVD coating
 HW: uncoated carbide JU: uncoated

APPLICATION CHART

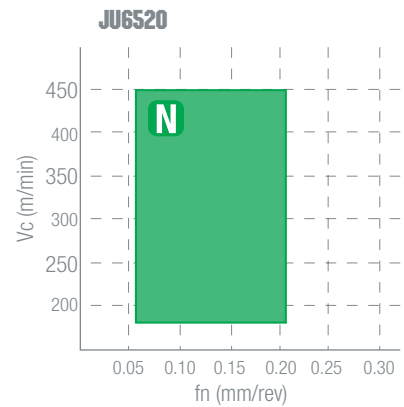
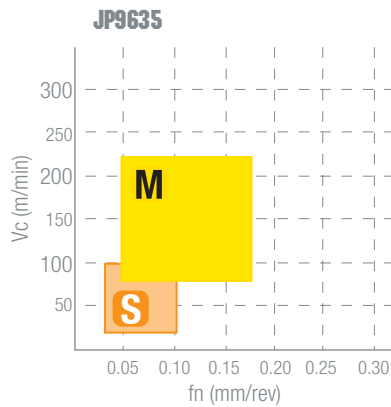
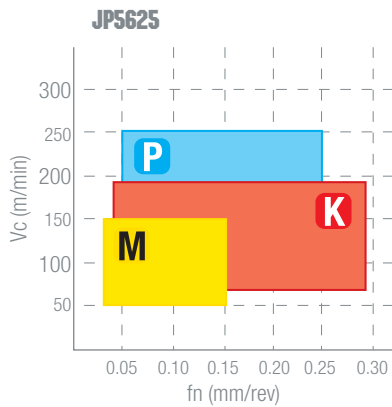

DRS DRILLING SYSTEM

HOLDERS 2XD

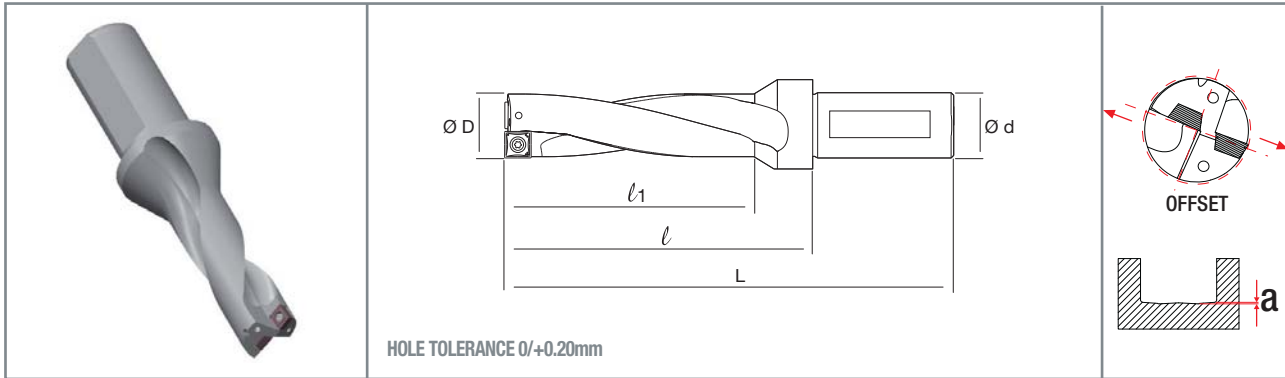

SP□□	DESCRIPTION	STOCK	DIMENSIONS					NT-DRS	NT-FTB	TORQUE Nm	MAX RADIAL OFFSET mm	a mm
			ØD	Ød	L	l	l1					
SPMX0502 SPGX0502	NT-DRS-2D D12.50-S20-05	○	12.5	20	94	44	26	NT-ST059	NT-FTB06	0.50	0.50	0.4
	D13.00-S20-05	●	13	20	94	44	26	NT-ST059	NT-FTB06	0.50	0.50	0.4
	D13.50-S20-05	○	13.5	20	96	46	28	NT-ST059	NT-FTB06	0.50	0.50	0.4
	D14.00-S20-05	●	14	20	96	46	28	NT-ST059	NT-FTB06	0.50	0.50	0.4
	D14.50-S20-05	○	14.5	20	99	49	30	NT-ST059	NT-FTB06	0.50	0.50	0.4
	D15.00-S20-05	●	15	20	99	49	30	NT-ST059	NT-FTB06	0.50	0.50	0.4
SPMX0602 SPGX0602	NT-DRS-2D D15.50-S25-06	○	15.5	25	108	52	32	NT-ST061	NT-FTB06	0.50	0.50	0.5
	D16.00-S25-06	●	16	25	108	52	32	NT-ST061	NT-FTB06	0.50	0.50	0.5
	D16.50-S25-06	○	16.5	25	110	54	34	NT-ST061	NT-FTB06	0.50	0.50	0.5
	D17.00-S25-06	●	17	25	110	54	34	NT-ST061	NT-FTB06	0.50	0.50	0.5
	D17.50-S25-06	○	17.5	25	113	57	36	NT-ST061	NT-FTB06	0.50	0.50	0.5
	D18.00-S25-06	●	18	25	113	57	36	NT-ST061	NT-FTB06	0.50	0.50	0.5
	D18.50-S25-06	○	18.5	25	115	59	38	NT-ST061	NT-FTB06	0.50	0.50	0.5
	D19.00-S25-06	●	19	25	115	59	38	NT-ST061	NT-FTB06	0.50	0.50	0.5
	D19.50-S25-06	○	19.5	25	119	63	40	NT-ST061	NT-FTB06	0.50	0.50	0.5
	D20.00-S25-06	●	20	25	119	63	40	NT-ST061	NT-FTB06	0.50	0.50	0.5
	D20.50-S25-06	○	20.5	25	121	65	42	NT-ST061	NT-FTB06	0.50	0.50	0.5
	D21.00-S25-06	●	21	25	121	65	42	NT-ST061	NT-FTB06	0.50	0.25	0.5
D21.50-S25-06	○	21.5	25	123	67	44	NT-ST061	NT-FTB06	0.50	0.25	0.5	
SPMX07T3 SPGX07T3	NT-DRS-2D D22.00-S25-07	●	22	25	123	67	44	NT-ST062	NT-FTB07	0.80	0.50	0.5
	D22.50-S32-07	○	22.5	32	131	71	46	NT-ST062	NT-FTB07	0.80	0.50	0.5
	D23.00-S32-07	●	23	32	131	71	46	NT-ST062	NT-FTB07	0.80	0.50	0.5
	D23.50-S32-07	○	23.5	32	134	74	48	NT-ST062	NT-FTB07	0.80	0.50	0.5
	D24.00-S32-07	●	24	32	134	74	48	NT-ST062	NT-FTB07	0.80	0.50	0.5
	D24.50-S32-07	○	24.5	32	137	77	50	NT-ST062	NT-FTB07	0.80	0.50	0.5
	D25.00-S32-07	●	25	32	137	77	50	NT-ST062	NT-FTB07	0.80	0.50	0.5
	D25.50-S32-07	○	25.5	32	139	79	52	NT-ST062	NT-FTB07	0.80	0.50	0.6
	D26.00-S32-07	●	26	32	139	79	52	NT-ST062	NT-FTB07	0.80	0.25	0.6
	D26.50-S32-07	○	26.5	32	141	81	54	NT-ST062	NT-FTB07	0.80	0.25	0.6
	D27.00-S32-07	●	27	32	141	81	54	NT-ST062	NT-FTB07	0.80	0.25	0.6
D27.50-S32-07	○	27.5	32	144	84	56	NT-ST062	NT-FTB07	0.80	0.25	0.6	
SPMX0904 SPGX0904	NT-DRS-2D D28.00-S32-09	●	28	32	144	84	56	NT-ST063	NT-FTB15	3.50	0.50	0.8
	D28.50-S32-09	○	28.5	32	146	86	58	NT-ST063	NT-FTB15	3.50	0.50	0.8
	D29.00-S32-09	●	29	32	146	86	58	NT-ST063	NT-FTB15	3.50	0.50	0.8
	D29.50-S32-09	○	29.5	32	151	91	60	NT-ST063	NT-FTB15	3.50	0.50	0.8
	D30.00-S32-09	●	30	32	151	91	60	NT-ST063	NT-FTB15	3.50	0.50	0.8
	D31.00-S32-09	●	31	32	154	94	62	NT-ST063	NT-FTB15	3.50	0.25	0.8
	D32.00-S32-09	●	32	32	156	96	64	NT-ST063	NT-FTB15	3.50	0.25	0.8
	D33.00-S32-09	●	33	32	159	99	66	NT-ST063	NT-FTB15	3.50	0.25	0.8

● stock standard; ○ non stock standard

HOLDERS 2XD

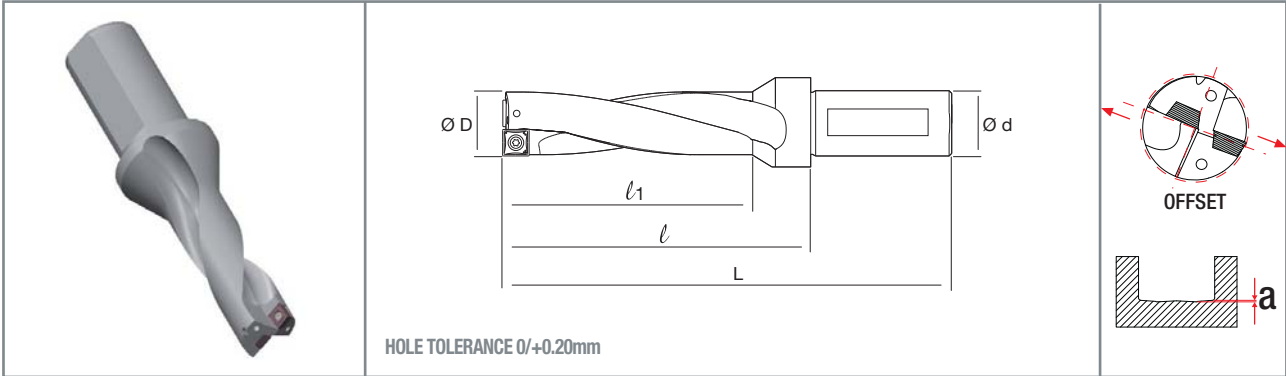

SP□□	DESCRIPTION	STOCK	DIMENSIONS								TORQUE Nm	MAX RADIAL OFFSET mm	a mm
			ØD	Ød	L	l	l1						
SPMX1104 SPGX1104	NT-DRS-2D D34.00-S40-11	●	34	40	171	101	68	NT-ST064	NT-FTB15	3.50	0.50	0.9	
	D35.00-S40-11	●	35	40	174	104	70	NT-ST064	NT-FTB15	3.50	0.50	0.9	
	D36.00-S40-11	●	36	40	177	107	72	NT-ST064	NT-FTB15	3.50	0.50	0.9	
	D37.00-S40-11	●	37	40	180	110	74	NT-ST064	NT-FTB15	3.50	0.50	0.9	
	D38.00-S40-11	●	38	40	183	113	76	NT-ST064	NT-FTB15	3.50	0.50	0.9	
	D39.00-S40-11	●	39	40	185	115	78	NT-ST064	NT-FTB15	3.50	0.50	0.9	
	D40.00-S40-11	●	40	40	188	118	80	NT-ST064	NT-FTB15	3.50	0.25	0.9	
	D41.00-S40-11	●	41	40	191	121	82	NT-ST064	NT-FTB15	3.50	0.25	0.9	
SPMX1405 SPGX1405	NT-DRS-2D D42.00-S40-14	●	42	40	193	123	84	NT-ST066	NT-FTB20	4.50	0.50	1.0	
	D43.00-S40-14	●	43	40	196	126	86	NT-ST066	NT-FTB20	4.50	0.50	1.0	
	D44.00-S40-14	●	44	40	198	128	88	NT-ST066	NT-FTB20	4.50	0.50	1.0	
	D45.00-S40-14	●	45	40	202	132	90	NT-ST066	NT-FTB20	4.50	0.50	1.0	
	D46.00-S40-14	●	46	40	205	135	92	NT-ST066	NT-FTB20	4.50	0.50	1.0	
	D47.00-S40-14	●	47	40	207	137	94	NT-ST066	NT-FTB20	4.50	0.50	1.0	
	D48.00-S40-14	●	48	40	210	140	96	NT-ST066	NT-FTB20	4.50	0.25	1.0	
	D49.00-S40-14	●	49	40	212	142	98	NT-ST066	NT-FTB20	4.50	0.25	1.0	
D50.00-S40-14	●	50	40	215	145	100	NT-ST066	NT-FTB20	4.50	0.25	1.0		

● stock standard

DRS DRILLING SYSTEM

HOLDERS 3XD

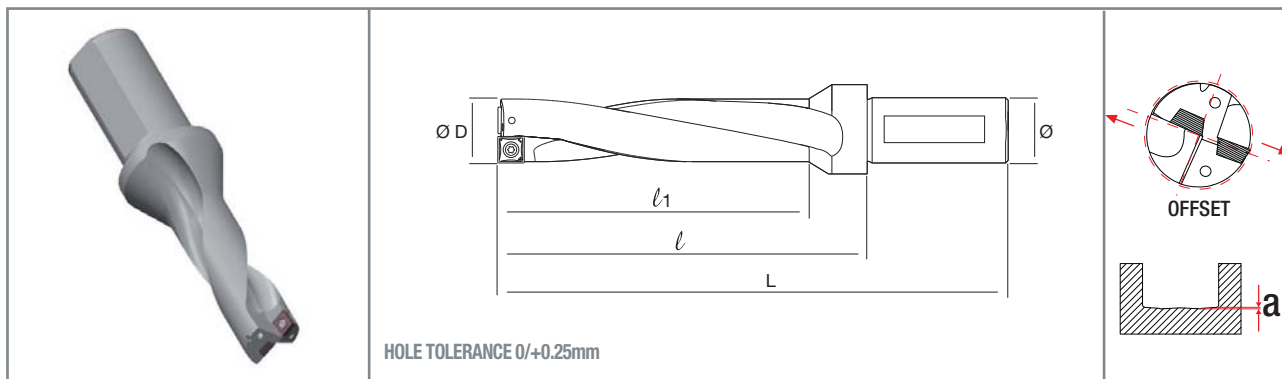

SP□□	DESCRIPTION	STOCK	DIMENSIONS						TORQUE Nm	MAX RADIAL OFFSET mm	a mm	
			ØD	Ød	L	l	l ₁					
SPMX0502 SPGX0502	NT-DRS-3D D12.50-S20-05	●	12.5	20	107	57	39	NT-ST059	NT-FTB06	0.50	0.50	0.4
	D13.00-S20-05	●	13	20	107	57	39	NT-ST059	NT-FTB06	0.50	0.50	0.4
	D13.50-S20-05	●	13.5	20	110	60	42	NT-ST059	NT-FTB06	0.50	0.50	0.4
	D14.00-S20-05	●	14	20	110	60	42	NT-ST059	NT-FTB06	0.50	0.50	0.4
	D14.50-S20-05	●	14.5	20	114	64	45	NT-ST059	NT-FTB06	0.50	0.50	0.4
	D15.00-S20-05	●	15	20	114	64	45	NT-ST059	NT-FTB06	0.50	0.50	0.4
SPMX0602 SPGX0602	NT-DRS-3D D15.50-S25-06	●	15.5	25	124	68	48	NT-ST061	NT-FTB06	0.50	0.50	0.5
	D16.00-S25-06	●	16	25	124	68	48	NT-ST061	NT-FTB06	0.50	0.50	0.5
	D16.50-S25-06	●	16.5	25	127	71	51	NT-ST061	NT-FTB06	0.50	0.50	0.5
	D17.00-S25-06	●	17	25	127	71	51	NT-ST061	NT-FTB06	0.50	0.50	0.5
	D17.50-S25-06	●	17.5	25	131	75	54	NT-ST061	NT-FTB06	0.50	0.50	0.5
	D18.00-S25-06	●	18	25	131	75	54	NT-ST061	NT-FTB06	0.50	0.50	0.5
	D18.50-S25-06	●	18.5	25	134	78	57	NT-ST061	NT-FTB06	0.50	0.50	0.5
	D19.00-S25-06	●	19	25	134	78	57	NT-ST061	NT-FTB06	0.50	0.50	0.5
	D19.50-S25-06	●	19.5	25	139	83	60	NT-ST061	NT-FTB06	0.50	0.50	0.5
	D20.00-S25-06	●	20	25	139	83	60	NT-ST061	NT-FTB06	0.50	0.50	0.5
	D20.50-S25-06	●	20.5	25	142	86	63	NT-ST061	NT-FTB06	0.50	0.50	0.5
	D21.00-S25-06	●	21	25	142	86	63	NT-ST061	NT-FTB06	0.50	0.25	0.5
D21.50-S25-06	●	21.5	25	145	89	66	NT-ST061	NT-FTB06	0.50	0.25	0.5	
SPMX07T3 SPGX07T3	NT-DRS-3D D22.00-S25-07	●	22	25	145	89	66	NT-ST062	NT-FTB07	0.80	0.50	0.5
	D22.50-S32-07	●	22.5	32	154	94	69	NT-ST062	NT-FTB07	0.80	0.50	0.5
	D23.00-S32-07	●	23	32	154	94	69	NT-ST062	NT-FTB07	0.80	0.50	0.5
	D23.50-S32-07	●	23.5	32	158	98	72	NT-ST062	NT-FTB07	0.80	0.50	0.5
	D24.00-S32-07	●	24	32	158	98	72	NT-ST062	NT-FTB07	0.80	0.50	0.5
	D24.50-S32-07	●	24.5	32	162	102	75	NT-ST062	NT-FTB07	0.80	0.50	0.5
	D25.00-S32-07	●	25	32	162	102	75	NT-ST062	NT-FTB07	0.80	0.50	0.5
	D25.50-S32-07	●	25.5	32	165	105	78	NT-ST062	NT-FTB07	0.80	0.50	0.6
	D26.00-S32-07	●	26	32	165	105	78	NT-ST062	NT-FTB07	0.80	0.25	0.6
	D26.50-S32-07	●	26.5	32	168	108	81	NT-ST062	NT-FTB07	0.80	0.25	0.6
	D27.00-S32-07	●	27	32	168	108	81	NT-ST062	NT-FTB07	0.80	0.25	0.6
D27.50-S32-07	●	27.5	32	172	112	84	NT-ST062	NT-FTB07	0.80	0.25	0.6	
SPMX0904 SPGX0904	NT-DRS-3D D28.00-S32-09	●	28	32	172	112	84	NT-ST063	NT-FTB15	3.50	0.50	0.8
	D28.50-S32-09	●	28.5	32	175	115	87	NT-ST063	NT-FTB15	3.50	0.50	0.8
	D29.00-S32-09	●	29	32	175	115	87	NT-ST063	NT-FTB15	3.50	0.50	0.8
	D29.50-S32-09	●	29.5	32	181	121	90	NT-ST063	NT-FTB15	3.50	0.50	0.8
	D30.00-S32-09	●	30	32	181	121	90	NT-ST063	NT-FTB15	3.50	0.50	0.8
	D31.00-S32-09	●	31	32	185	125	93	NT-ST063	NT-FTB15	3.50	0.25	0.8
	D32.00-S32-09	●	32	32	188	128	96	NT-ST063	NT-FTB15	3.50	0.25	0.8
D33.00-S32-09	●	33	32	192	132	99	NT-ST063	NT-FTB15	3.50	0.25	0.8	

● stock standard

HOLDERS 3XD

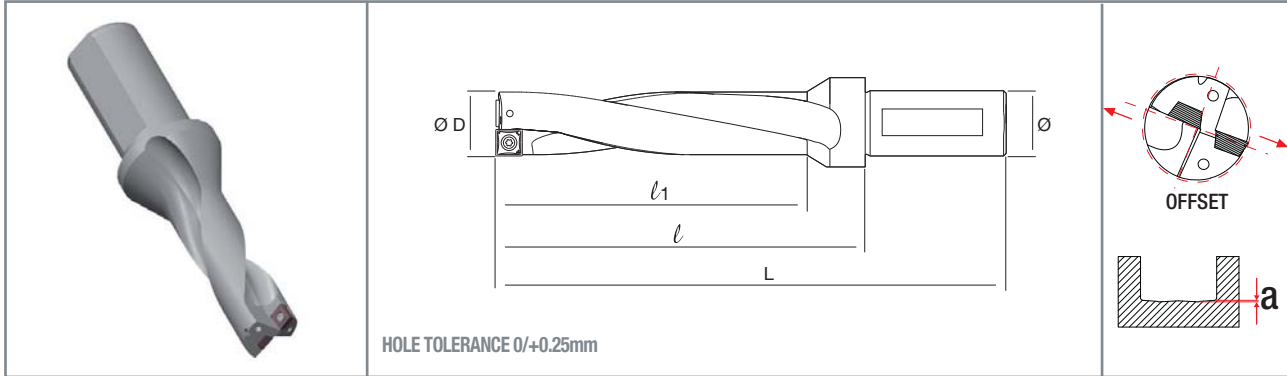

SP□□	DESCRIPTION	STOCK	DIMENSIONS								TORQUE Nm	MAX RADIAL OFFSET mm	a mm
			ØD	Ød	L	l	l1						
SPMX1104 SPGX1104	NT-DRS-3D D34.00-S40-11	●	34	40	205	135	102	NT-ST064	NT-FTB15	3.50	0.50	0.9	
	D35.00-S40-11	●	35	40	209	139	105	NT-ST064	NT-FTB15	3.50	0.50	0.9	
	D36.00-S40-11	●	36	40	213	143	108	NT-ST064	NT-FTB15	3.50	0.50	0.9	
	D37.00-S40-11	●	37	40	217	147	111	NT-ST064	NT-FTB15	3.50	0.50	0.9	
	D38.00-S40-11	●	38	40	221	151	114	NT-ST064	NT-FTB15	3.50	0.50	0.9	
	D39.00-S40-11	●	39	40	224	154	117	NT-ST064	NT-FTB15	3.50	0.50	0.9	
	D40.00-S40-11	●	40	40	228	158	120	NT-ST064	NT-FTB15	3.50	0.25	0.9	
	D41.00-S40-11	●	41	40	232	162	123	NT-ST064	NT-FTB15	3.50	0.25	0.9	
SPMX1405 SPGX1405	NT-DRS-3D D42.00-S40-14	●	42	40	235	165	126	NT-ST066	NT-FTB20	4.50	0.50	1.0	
	D43.00-S40-14	●	43	40	239	169	129	NT-ST066	NT-FTB20	4.50	0.50	1.0	
	D44.00-S40-14	●	44	40	242	172	132	NT-ST066	NT-FTB20	4.50	0.50	1.0	
	D45.00-S40-14	●	45	40	247	177	135	NT-ST066	NT-FTB20	4.50	0.50	1.0	
	D46.00-S40-14	●	46	40	251	181	138	NT-ST066	NT-FTB20	4.50	0.50	1.0	
	D47.00-S40-14	●	47	40	254	184	141	NT-ST066	NT-FTB20	4.50	0.50	1.0	
	D48.00-S40-14	●	48	40	258	188	144	NT-ST066	NT-FTB20	4.50	0.25	1.0	
	D49.00-S40-14	●	49	40	261	191	147	NT-ST066	NT-FTB20	4.50	0.25	1.0	
D50.00-S40-14	●	50	40	265	195	150	NT-ST066	NT-FTB20	4.50	0.25	1.0		

● stock standard

DRS DRILLING SYSTEM

HOLDERS 4XD

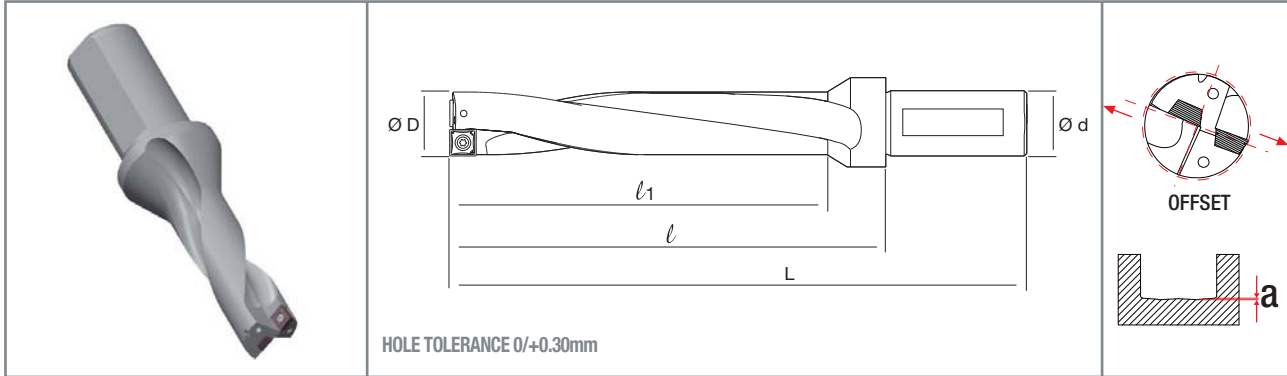

SP□□	DESCRIPTION	STOCK	DIMENSIONS						TORQUE Nm	MAX RADIAL OFFSET mm	a mm		
			ØD	Ød	L	l	l ₁						
SPMX0502 SPGX0502	NT-DRS-4D	D12.50-S20-05	●	12.5	20	120	70	52	NT-ST059	NT-FTB06	0.50	0.50	0.4
		D13.00-S20-05	●	13	20	120	70	52	NT-ST059	NT-FTB06	0.50	0.50	0.4
		D13.50-S20-05	●	13.5	20	124	74	56	NT-ST059	NT-FTB06	0.50	0.50	0.4
		D14.00-S20-05	●	14	20	124	74	56	NT-ST059	NT-FTB06	0.50	0.50	0.4
		D14.50-S20-05	●	14.5	20	129	79	60	NT-ST059	NT-FTB06	0.50	0.50	0.4
		D15.00-S20-05	●	15	20	129	79	60	NT-ST059	NT-FTB06	0.50	0.50	0.4
SPMX0602 SPGX0602	NT-DRS-4D	D15.50-S25-06	●	15.5	25	140	84	64	NT-ST061	NT-FTB06	0.50	0.50	0.5
		D16.00-S25-06	●	16	25	140	84	64	NT-ST061	NT-FTB06	0.50	0.50	0.5
		D16.50-S25-06	●	16.5	25	144	88	68	NT-ST061	NT-FTB06	0.50	0.50	0.5
		D17.00-S25-06	●	17	25	144	88	68	NT-ST061	NT-FTB06	0.50	0.50	0.5
		D17.50-S25-06	●	17.5	25	149	93	72	NT-ST061	NT-FTB06	0.50	0.50	0.5
		D18.00-S25-06	●	18	25	149	93	72	NT-ST061	NT-FTB06	0.50	0.50	0.5
		D18.50-S25-06	●	18.5	25	153	97	76	NT-ST061	NT-FTB06	0.50	0.50	0.5
		D19.00-S25-06	●	19	25	153	97	76	NT-ST061	NT-FTB06	0.50	0.50	0.5
		D19.50-S25-06	●	19.5	25	159	103	80	NT-ST061	NT-FTB06	0.50	0.50	0.5
		D20.00-S25-06	●	20	25	159	103	80	NT-ST061	NT-FTB06	0.50	0.50	0.5
		D20.50-S25-06	●	20.5	25	163	107	84	NT-ST061	NT-FTB06	0.50	0.50	0.5
		D21.00-S25-06	●	21	25	163	107	84	NT-ST061	NT-FTB06	0.50	0.25	0.5
D21.50-S25-06	●	21.5	25	167	111	88	NT-ST061	NT-FTB06	0.50	0.25	0.5		
SPMX07T3 SPGX07T3	NT-DRS-4D	D22.00-S25-07	●	22	25	167	111	88	NT-ST062	NT-FTB07	0.80	0.50	0.5
		D22.50-S32-07	●	22.5	32	177	117	92	NT-ST062	NT-FTB07	0.80	0.50	0.5
		D23.00-S32-07	●	23	32	177	117	92	NT-ST062	NT-FTB07	0.80	0.50	0.5
		D23.50-S32-07	●	23.5	32	182	122	96	NT-ST062	NT-FTB07	0.80	0.50	0.5
		D24.00-S32-07	●	24	32	182	122	96	NT-ST062	NT-FTB07	0.80	0.50	0.5
		D24.50-S32-07	●	24.5	32	187	127	100	NT-ST062	NT-FTB07	0.80	0.50	0.5
		D25.00-S32-07	●	25	32	187	127	100	NT-ST062	NT-FTB07	0.80	0.50	0.5
		D25.50-S32-07	●	25.5	32	191	131	104	NT-ST062	NT-FTB07	0.80	0.50	0.6
		D26.00-S32-07	●	26	32	191	131	104	NT-ST062	NT-FTB07	0.80	0.25	0.6
		D26.50-S32-07	●	26.5	32	195	135	108	NT-ST062	NT-FTB07	0.80	0.25	0.6
		D27.00-S32-07	●	27	32	195	135	108	NT-ST062	NT-FTB07	0.80	0.25	0.6
		D27.50-S32-07	●	27.5	32	200	140	112	NT-ST062	NT-FTB07	0.80	0.25	0.6
SPMX0904 SPGX0904	NT-DRS-4D	D28.00-S32-09	●	28	32	200	140	112	NT-ST063	NT-FTB15	3.50	0.50	0.8
		D28.50-S32-09	●	28.5	32	204	144	116	NT-ST063	NT-FTB15	3.50	0.50	0.8
		D29.00-S32-09	●	29	32	204	144	116	NT-ST063	NT-FTB15	3.50	0.50	0.8
		D29.50-S32-09	●	29.5	32	211	151	120	NT-ST063	NT-FTB15	3.50	0.50	0.8
		D30.00-S32-09	●	30	32	211	151	120	NT-ST063	NT-FTB15	3.50	0.50	0.8
		D31.00-S32-09	●	31	32	216	156	124	NT-ST063	NT-FTB15	3.50	0.25	0.8
		D32.00-S32-09	●	32	32	220	160	128	NT-ST063	NT-FTB15	3.50	0.25	0.8
D33.00-S32-09	●	33	32	225	165	132	NT-ST063	NT-FTB15	3.50	0.25	0.8		

● stock standard

HOLDERS 4XD

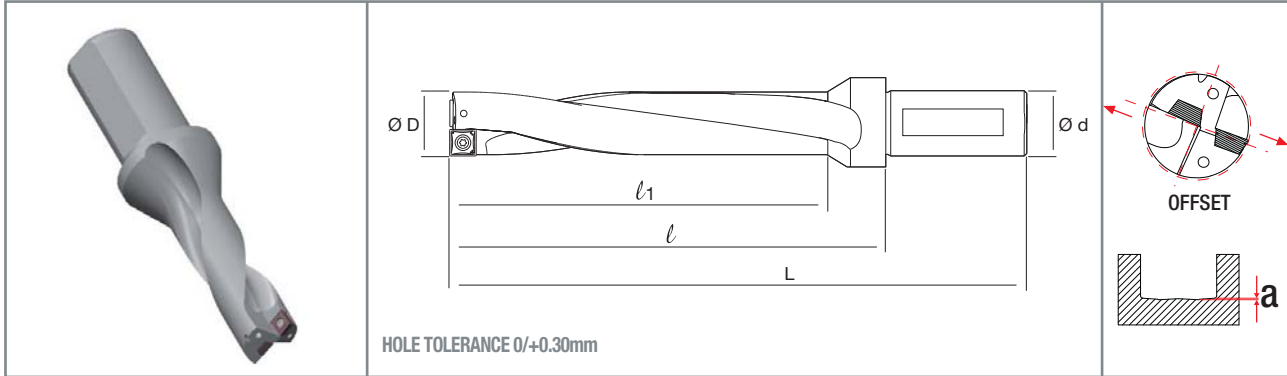

SP□□	DESCRIPTION	STOCK	DIMENSIONS								TORQUE Nm	MAX RADIAL OFFSET mm	a mm
			ØD	Ød	L	l	l ₁						
SPMX1104 SPGX1104	NT-DRS-4D D34.00-S40-11	●	34	40	239	169	136	NT-ST064	NT-FTB15	3.50	0.50	0.9	
	D35.00-S40-11	●	35	40	244	174	140	NT-ST064	NT-FTB15	3.50	0.50	0.9	
	D36.00-S40-11	●	36	40	249	179	144	NT-ST064	NT-FTB15	3.50	0.50	0.9	
	D37.00-S40-11	●	37	40	254	184	148	NT-ST064	NT-FTB15	3.50	0.50	0.9	
	D38.00-S40-11	●	38	40	259	189	152	NT-ST064	NT-FTB15	3.50	0.50	0.9	
	D39.00-S40-11	●	39	40	263	193	156	NT-ST064	NT-FTB15	3.50	0.50	0.9	
	D40.00-S40-11	●	40	40	268	198	160	NT-ST064	NT-FTB15	3.50	0.25	0.9	
	D41.00-S40-11	●	41	40	273	203	164	NT-ST064	NT-FTB15	3.50	0.25	0.9	
SPMX1405 SPGX1405	NT-DRS-4D D42.00-S40-14	●	42	40	277	207	168	NT-ST066	NT-FTB20	4.50	0.50	1.0	
	D43.00-S40-14	●	43	40	282	212	172	NT-ST066	NT-FTB20	4.50	0.50	1.0	
	D44.00-S40-14	●	44	40	286	216	176	NT-ST066	NT-FTB20	4.50	0.50	1.0	
	D45.00-S40-14	●	45	40	292	222	180	NT-ST066	NT-FTB20	4.50	0.50	1.0	
	D46.00-S40-14	●	46	40	297	227	184	NT-ST066	NT-FTB20	4.50	0.50	1.0	
	D47.00-S40-14	●	47	40	301	231	188	NT-ST066	NT-FTB20	4.50	0.50	1.0	
	D48.00-S40-14	●	48	40	306	236	192	NT-ST066	NT-FTB20	4.50	0.25	1.0	
	D49.00-S40-14	●	49	40	310	240	196	NT-ST066	NT-FTB20	4.50	0.25	1.0	
D50.00-S40-14	●	50	40	315	245	200	NT-ST066	NT-FTB20	4.50	0.25	1.0		

● stock standard

DRS DRILLING SYSTEM

CUTTING SPEED (Vc m/min)

Gr.	MATERIAL		
P1	Free cutting steel and structural steel	Rm < 500 N/mm ²	(9SMn28 / 1.0715 / AVP)
P2	Carbon steel and low alloy steel	Rm 500-700 N/mm ²	(C40 / 1.0511)
P3	Medium alloy steel and heat treated steel	Rm 600-800 N/mm ²	(42CrMo4 / 1.7225)
P4	High alloy steel	Rm 800-1000 N/mm ²	(100Cr6 / 1.3505)
P5	Tool steel	Rm 900-1200 N/mm ²	(X210Cr12 / 1.2080 / K100)
P6	High tensile strength steel	Rm 1200-1600 N/mm ²	(X2NiCrMo18.9.5 / 1.6358 / W720)
M1	Ferritic stainless steel	Rm 400-700 N/mm ²	(X40Cr13 / 1.4034 / AISI420)
M2	Austenitic stainless steel (good machinability)	Rm 500-750 N/mm ²	(X5CrNi18.10 / 1.4301 / AISI304)
M3	Austenitic stainless steel (medium machinability)	Rm 550-850 N/mm ²	(X2CrNiMo18.12 / 1.4435 / AISI316L)
M4	Martensitic stainless steel	Rm 650-950 N/mm ²	(X2CrNiMoN25.7.4 / 1.4410 / Super Duplex)
M5	PH stainless steel	Rm 800-1250 N/mm ²	(X5CrNiNb16.4 / 1.4542 / 17-4PH)
K1	Grey cast iron	HB 150-250	(GG-25 / 0.6025)
K2	Nodular cast iron	HB 150-350	(GGG-50 / 0.7050)
K3	Austenitic cast iron	HB 120-260	(GGL-NiCr20.2 / 0.6660)
K4	ADI cast iron	HB 250-500	(GJS-1000-5 / ADI 1000)
N1	Aluminium alloys < 12% Si		(AlMgSi0.5 / 3.3206)
N2	Aluminium alloys > 12% Si		(AlSi12 / 3.2582)
N3	Copper alloys		(E-Cu57 / 2.0060)
N4	Brass alloys and bronze alloys		(CuZn20Al2 / 2.0460)
S1	Heat resistant super alloys HRSA (good machinability)	HRC < 25	(NiCr17Mo17FeW / 2.4802 / Hastelloy)
S2	Heat resistant super alloys HRSA (medium machinability)	HRC 25-35	(NiCr20Ti / 2.4630 / Nimonic 80)
S3	Heat resistant super alloys HRSA (low machinability)	HRC 35-45	(NiCr19Fe19NbMo / 2.4668 / Inconel 718)
S4	Low alloy titanium		(Ti99.6 / 3.7055 / Titanium grade 3)
S5	High alloy titanium		(Ti5Al2.5Sn / 3.7115 / Titanium grade 6)

Gr.	Vc m/min			fn mm/rev Ø12.50÷15.00		fn mm/rev Ø15.50÷21.50		fn mm/rev Ø22.00÷33.00		fn mm/rev Ø34.00÷50.00	
	JP5625	JP9635	JU6520	2D, 3D	4D	2D, 3D	4D	2D, 3D	4D	2D, 3D	4D
P1	180 ÷ 250			0.05 ÷ 0.10	0.04 ÷ 0.07	0.06 ÷ 0.12	0.05 ÷ 0.08	0.07 ÷ 0.14	0.06 ÷ 0.11	0.08 ÷ 0.16	0.07 ÷ 0.14
P2	120 ÷ 200			0.07 ÷ 0.14	0.05 ÷ 0.10	0.09 ÷ 0.18	0.06 ÷ 0.13	0.11 ÷ 0.22	0.09 ÷ 0.18	0.12 ÷ 0.25	0.11 ÷ 0.22
P3	100 ÷ 180			0.06 ÷ 0.12	0.04 ÷ 0.08	0.08 ÷ 0.16	0.06 ÷ 0.11	0.10 ÷ 0.20	0.08 ÷ 0.16	0.11 ÷ 0.22	0.10 ÷ 0.20
P4	100 ÷ 150			0.06 ÷ 0.12	0.04 ÷ 0.08	0.08 ÷ 0.16	0.06 ÷ 0.11	0.10 ÷ 0.20	0.08 ÷ 0.16	0.11 ÷ 0.22	0.10 ÷ 0.20
P5	80 ÷ 140			0.05 ÷ 0.10	0.04 ÷ 0.07	0.07 ÷ 0.12	0.05 ÷ 0.08	0.09 ÷ 0.18	0.07 ÷ 0.14	0.10 ÷ 0.20	0.09 ÷ 0.18
P6	80 ÷ 120			0.04 ÷ 0.08	0.03 ÷ 0.06	0.06 ÷ 0.12	0.04 ÷ 0.08	0.08 ÷ 0.16	0.06 ÷ 0.13	0.09 ÷ 0.18	0.08 ÷ 0.16
M1	100 ÷ 150	120 ÷ 220		0.05 ÷ 0.10	0.04 ÷ 0.07	0.06 ÷ 0.12	0.05 ÷ 0.08	0.07 ÷ 0.14	0.06 ÷ 0.12	0.08 ÷ 0.16	0.07 ÷ 0.14
M2	80 ÷ 140	100 ÷ 200		0.05 ÷ 0.08	0.04 ÷ 0.06	0.06 ÷ 0.10	0.04 ÷ 0.08	0.07 ÷ 0.12	0.06 ÷ 0.10	0.08 ÷ 0.14	0.07 ÷ 0.13
M3	80 ÷ 120	120 ÷ 180		0.04 ÷ 0.08	0.03 ÷ 0.06	0.05 ÷ 0.10	0.04 ÷ 0.08	0.06 ÷ 0.12	0.05 ÷ 0.10	0.07 ÷ 0.14	0.06 ÷ 0.13
M4		90 ÷ 150		0.04 ÷ 0.07	0.03 ÷ 0.06	0.04 ÷ 0.08	0.03 ÷ 0.07	0.05 ÷ 0.10	0.04 ÷ 0.08	0.06 ÷ 0.12	0.05 ÷ 0.11
M5		80 ÷ 140		0.04 ÷ 0.07	0.03 ÷ 0.06	0.04 ÷ 0.08	0.03 ÷ 0.07	0.05 ÷ 0.10	0.04 ÷ 0.08	0.06 ÷ 0.12	0.05 ÷ 0.11
K1	120 ÷ 180			0.08 ÷ 0.16	0.06 ÷ 0.11	0.09 ÷ 0.18	0.06 ÷ 0.13	0.12 ÷ 0.25	0.10 ÷ 0.20	0.15 ÷ 0.30	0.13 ÷ 0.27
K2	80 ÷ 160			0.07 ÷ 0.14	0.05 ÷ 0.10	0.08 ÷ 0.16	0.05 ÷ 0.11	0.10 ÷ 0.20	0.08 ÷ 0.16	0.12 ÷ 0.24	0.11 ÷ 0.21
K3	80 ÷ 120			0.06 ÷ 0.12	0.04 ÷ 0.09	0.07 ÷ 0.14	0.05 ÷ 0.10	0.10 ÷ 0.16	0.08 ÷ 0.13	0.12 ÷ 0.20	0.10 ÷ 0.18
K4	60 ÷ 100			0.05 ÷ 0.10	0.04 ÷ 0.07	0.06 ÷ 0.12	0.04 ÷ 0.08	0.08 ÷ 0.14	0.06 ÷ 0.11	0.10 ÷ 0.18	0.08 ÷ 0.16
N1			250 ÷ 450	0.06 ÷ 0.12	0.04 ÷ 0.08	0.08 ÷ 0.16	0.06 ÷ 0.11	0.10 ÷ 0.20	0.08 ÷ 0.16	0.11 ÷ 0.22	0.10 ÷ 0.20
N2			230 ÷ 400	0.06 ÷ 0.12	0.04 ÷ 0.08	0.08 ÷ 0.16	0.06 ÷ 0.11	0.10 ÷ 0.20	0.08 ÷ 0.16	0.11 ÷ 0.22	0.10 ÷ 0.20
N3			200 ÷ 350	0.06 ÷ 0.12	0.04 ÷ 0.08	0.08 ÷ 0.16	0.06 ÷ 0.11	0.10 ÷ 0.20	0.08 ÷ 0.16	0.11 ÷ 0.22	0.10 ÷ 0.20
N4			150 ÷ 300	0.06 ÷ 0.12	0.04 ÷ 0.08	0.08 ÷ 0.16	0.06 ÷ 0.11	0.10 ÷ 0.20	0.08 ÷ 0.16	0.11 ÷ 0.22	0.10 ÷ 0.20
S1		30 ÷ 60		0.04 ÷ 0.07	0.03 ÷ 0.06	0.04 ÷ 0.08	0.03 ÷ 0.07	0.05 ÷ 0.10	0.04 ÷ 0.08	0.06 ÷ 0.12	0.05 ÷ 0.11
S2		30 ÷ 50		0.04 ÷ 0.07	0.03 ÷ 0.06	0.04 ÷ 0.08	0.03 ÷ 0.07	0.05 ÷ 0.10	0.04 ÷ 0.08	0.06 ÷ 0.12	0.05 ÷ 0.11
S3		20 ÷ 40		0.04 ÷ 0.07	0.03 ÷ 0.06	0.04 ÷ 0.08	0.03 ÷ 0.07	0.05 ÷ 0.10	0.04 ÷ 0.08	0.06 ÷ 0.12	0.05 ÷ 0.11
S4		50 ÷ 100		0.05 ÷ 0.08	0.04 ÷ 0.06	0.06 ÷ 0.10	0.04 ÷ 0.08	0.07 ÷ 0.12	0.06 ÷ 0.10	0.08 ÷ 0.14	0.07 ÷ 0.13
S5		40 ÷ 80		0.05 ÷ 0.08	0.04 ÷ 0.06	0.06 ÷ 0.10	0.04 ÷ 0.08	0.07 ÷ 0.12	0.06 ÷ 0.10	0.08 ÷ 0.14	0.07 ÷ 0.13



DOUBLE HEX SERIES

The first choice for cast iron milling.

ISO

K

- carbide (CVD, PVD)
- ceramic (Si_3N_4)
- solid PCBN

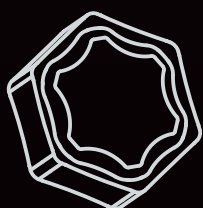

12 edges

nixkoTOOLS

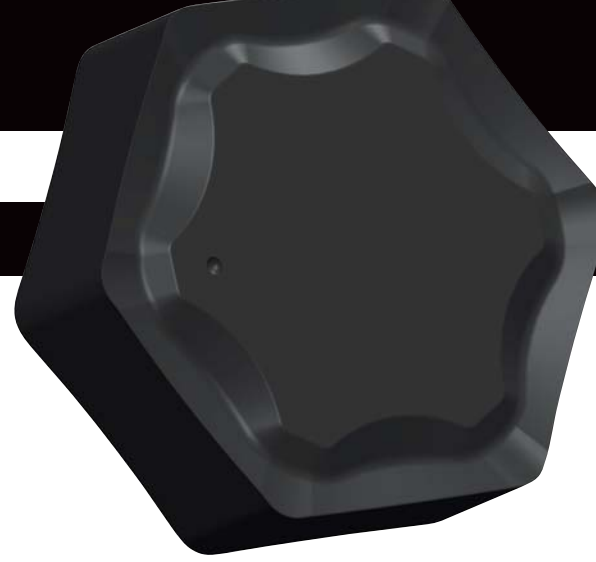

DOUBLE HEX SERIES

The first choice for cast iron milling.



- High performance milling system based on double-sided 12-edged inserts
- The 60° positioning angle and the proprietary insert geometries provide a balanced mix of machining stability and low cutting forces.
- The broad range available, including coated carbide grades (both PVD and CVD), Silicon Nitride and solid PCBN, can match a wide variety of applications.



- Sistema di fresatura con inserti bi-laterali a 12 taglienti estremamente performante e competitivo.
- L'angolo di registrazione di 60° e le speciali geometrie degli inserti assicurano un'ottima combinazione tra stabilità di lavorazione e sforzi di taglio.
- Grande versatilità grazie alla disponibilità di inserti in metallo duro rivestito (sia PVD che CVD), nitruro di silicio e PCBN solido in grado di soddisfare qualsiasi esigenza produttiva.



- Frässystem mit doppelseitigen Einsätzen mit 12 Schneiden. sehr Leistungs und konkurrenzfähig.
- Der Aufnahmewinkel von 60° und die speziellen Wendepultengeometrien sorgen für eine gute Kombination von Maschinenstabilität und Schneid Aufwand.
- Große Vielseitigkeit dank der Verfügbarkeit von beschichteten Wendeschneidplatten (sowohl PVD, CVD), Siliziumnitrid und PCBN können alle Produktionsanforderungen erfüllen.



- Système de fraisage avec plaquette bi-latérale à 12 arrêtes de coupe, extrêmement performant et compétitif.
- L'angle de prise de 60° et les géométries de plaquettes spéciales assurent une excellente combinaison de la stabilité et de l'effort de coupe.
- Une grande polyvalence grâce à la disponibilité d'inserts en carbure revêtus (à la fois PVD CVD), nitrure de silicium et PCBN solide capables de répondre à toutes les exigences de production.



- Sistema de fresado con placas de doble cara con 12 filos de corte de alto rendimiento.
- El ángulo de grabación de 60° y las geometrías especiales de los insertos garantizan una buena combinación de estabilidad de proceso y esfuerzo de corte.
- Gran versatilidad gracias a la disponibilidad de placas de metal duro recubiertas tanto PVD que CVD, nitruro de silicio y PCBN sólido que pueden cumplir con todas las necesidades de producción.



- Высокопроизводительная система для фрезерования с 12ю режущими кромками.
- 60° угол установки в сочетании со специальной геометрией пластины обеспечивает стабильность обработки и низкие рабочие усилия резания.
- Широкая гамма пластин из твёрдого сплава с покрытием (PVD или CVD), нитрида кремния и цельного КБН может быть применена для широкого круга задач.

HOLDERS

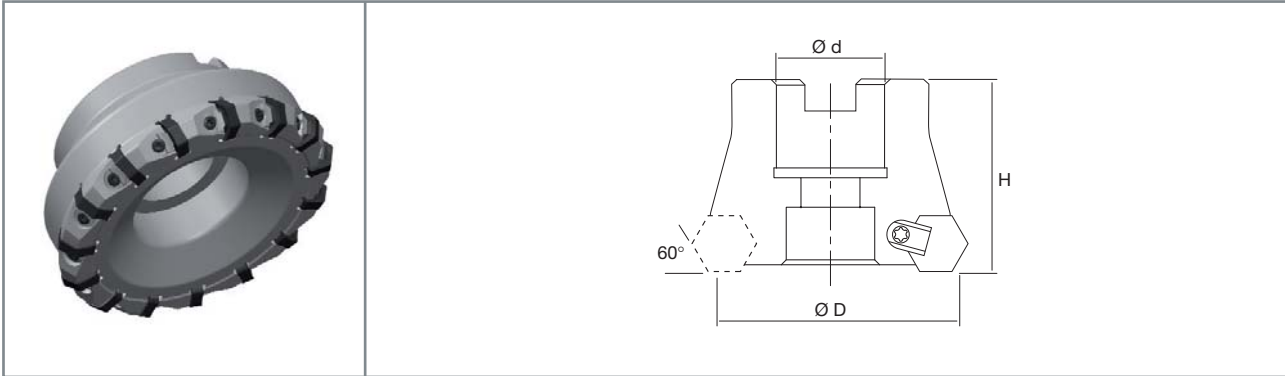

HN□□	DESCRIPTION	STOCK	DIMENSIONS				✕	NT-WD090	NT-SC090	NT-WR030	TORQUE Nm			
			ØD	Z	Ød	H								
HNEX0905	NT-HN09 D080-F27-Z8	●	80	8	27	50	✕	NT-WD090	NT-SC090	NT-WR030	7.0			
HNEN0905	D080-F27-Z10	●	80	10	27	50	✕	NT-WD090	NT-SC090	NT-WR030	7.0			
HNGN0905	D100-F32-Z10	●	100	10	32	50	✕	NT-WD090	NT-SC090	NT-WR030	7.0			
HNMx0905	D100-F32-Z14	●	100	14	32	50	✕	NT-WD090	NT-SC090	NT-WR030	7.0			
	D125-F40-Z15	●	125	15	40	63	✕	NT-WD090	NT-SC090	NT-WR030	7.0			
	D160-F40-Z20	●	160	20	40	63	✕	NT-WD090	NT-SC090	NT-WR030	7.0			

● stock standard

INSERTS

	DESCRIPTION					HC	CN	BH				
		IC	T	r	Ød	JC7515	JP7525	NSN400	NBS9000			
GL	HNEX 090510-GL	16.20	5.56	1.0	-	●	●					
	090520-GL	16.20	5.56	2.0	-	●	●					
GG	HNEX 090520-GG	16.20	5.56	2.0	-	●	●					
	HNMx 090520-GG	16.20	5.56	2.0	-	★	★					
GH	HNEX 090516-GH	16.20	5.56	1.6	-	●	●					
	090530-GH	16.20	5.56	3.0	-	●	●					
GP	HNEN 090520-GP	16.20	5.56	2.0	-			●				
	090530-GP	16.20	5.56	3.0	-			●				
GP	HNGN 090520-GP	16.20	5.56	2.0	-				★			

● stock standard; ★ upcoming introduction

HC: coated carbide
 CN: silicon nitride S₃N₄
 BH: PCBN with high CBN content

JP: PVD coating
 JC: CVD coating

DOUBLEHEX SERIES

GRADES APPLICATION CHART

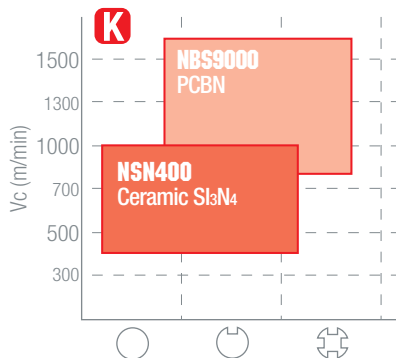
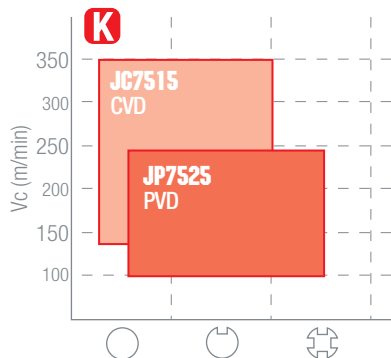

CHIPBREAKERS APPLICATION CHART

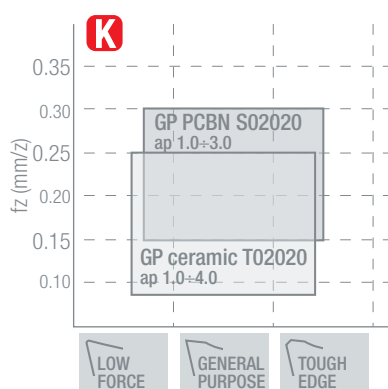
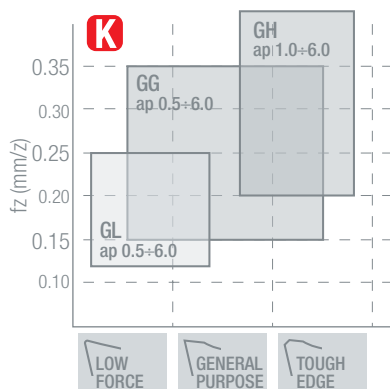

CUTTING SPEED (Vc m/min)

Gr.	MATERIAL			JC7515	JP7525	NSN400	NBS9000
K1	Grey cast iron	HB 150-250	(GG-25 / 0.6025)	200 ÷ 350	150 ÷ 240	600 ÷ 1000	800 ÷ 1500
K2	Nodular cast iron	HB 150-350	(GGG-50 / 0.7050)	180 ÷ 280	120 ÷ 200	400 ÷ 700	
K3	Austenitic cast iron	HB 120-260	(GGL-NiCr20.2 / 0.6660)	140 ÷ 200	100 ÷ 150		
K4	ADI cast iron	HB 250-500	(GJS-1000-5 / ADI 1000)	120 ÷ 180			



DOUBLE 4F FACE SERIES

Double up your productivity on face milling.

ISO

P

M

K

N

S

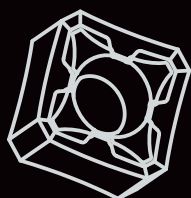
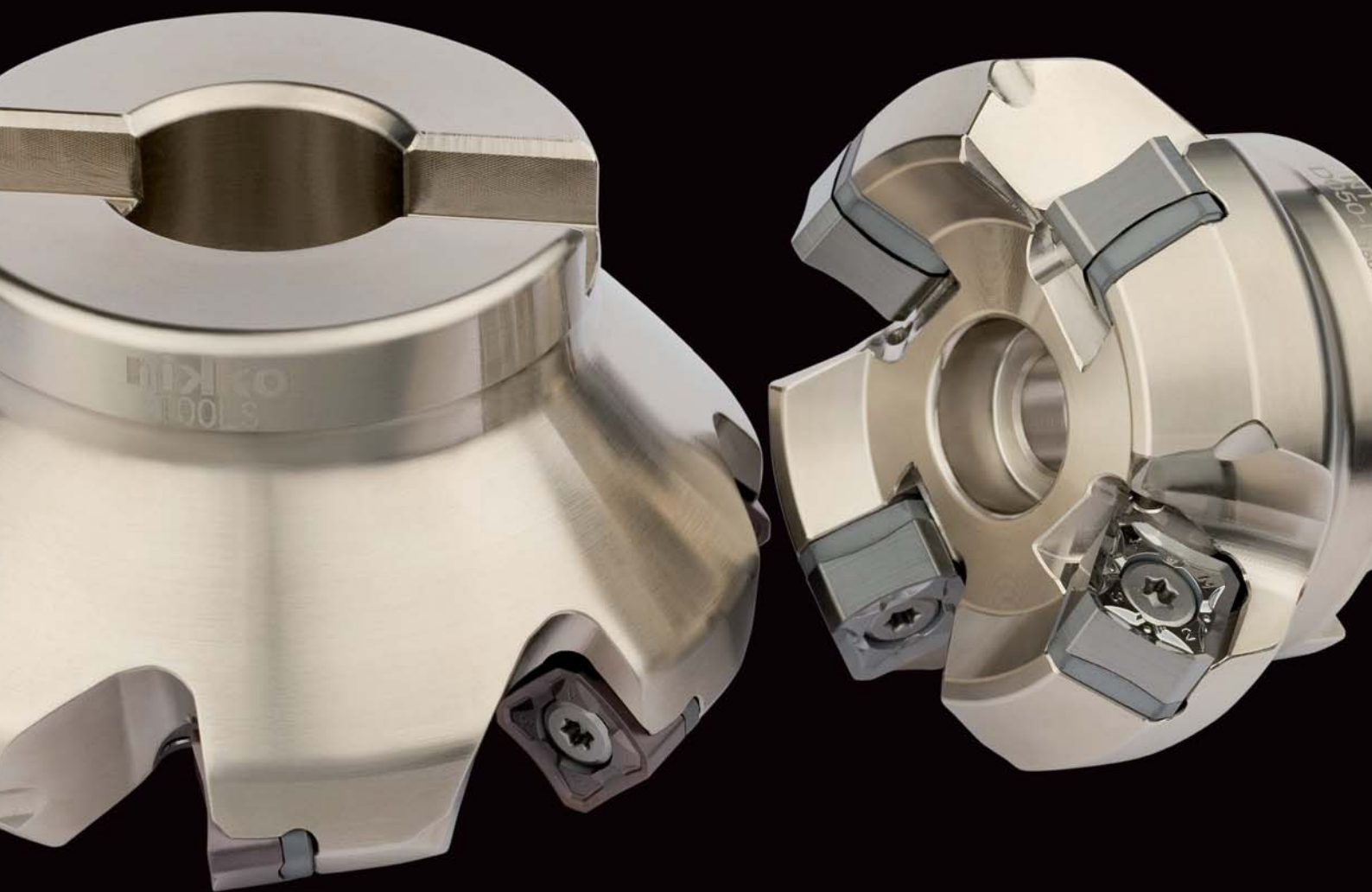

8 edges

nixkoTOOLS

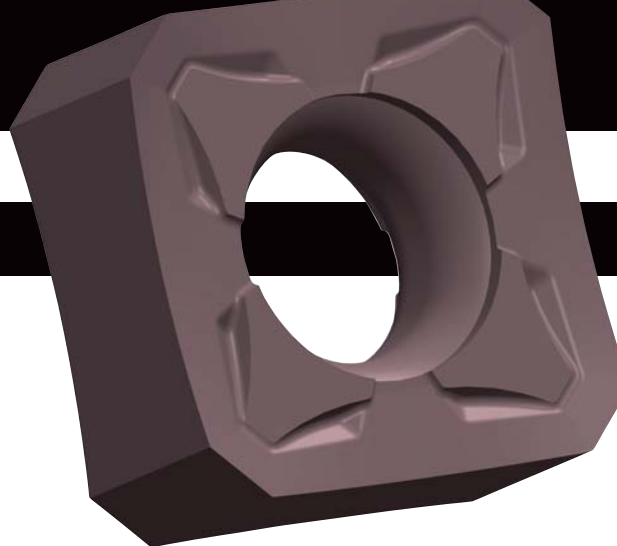

DOUBLE4FACE SERIES

Double up your productivity on face milling.



- Face milling with double-sided 8-edged square inserts.
- The lineup includes 5 different insert styles combined with 5 carbide grades, matching a wide range of applications.
- Thanks to the curved design of the cutting edge, allowing a dramatic reduction of cutting forces, the Double4Face system is eligible for use on setups where a limited power is available, as well as being an effective replacement for conventional positive inserts.



- Sistema per spianatura con inserti bilaterali quadrati ad 8 taglianti.
- 5 differenti geometrie di taglio abbinata a 5 gradi di metallo duro consentono l'applicazione su una grandissima varietà di materiali.
- La speciale geometria arcuata del tagliente riduce drasticamente gli sforzi di taglio consentendo l'utilizzo del sistema Double4Face anche su macchine poco potenti o in concorrenza a geometrie positive convenzionali.



- Stirnfräsen mit bilateralen 8 kantigen Wendescheidplatten.
- 5 verschiedene Schneidgeometrien kombiniert mit 5 Hartmetallsorten ermöglichen die Anwendung einer Vielzahl von Materialien.
- Die spezielle Geometrie der Schneidkante reduziert drastisch den Schneidaufwand, unter Verwendung des Systems Double4Face an Maschinen Poso mit leistungsstarken oder herkömmlichen positiven Geometrien.



- Système pour surfacage avec plaque bilatérale carrée à 8 arêtes de coupe.
- 5 différentes géométries de coupe associées à 5 nuances de carbure permettent une grande variété d'utilisation sur différents matériaux.
- La géométrie spéciale de l'arête de coupe arquée réduit drastiquement les efforts de coupe, permettant l'utilisation du système Double4Face même sur des machines peu puissantes ou en concurrence avec des géométries de plaque positives conventionnelles.



- Sistema de fresado frontal con placas cuadrada de doble cara con 8 filos.
- 5 geometrías de corte diferentes combinados con 5 grados de metal duro que permiten su aplicación a una amplia gama de materiales.
- La especial geometría arqueada del filo reduce drásticamente los esfuerzos de corte permitiendo el uso del sistema Double4Face también en máquinas con poca potencia o en competencia con geometrías positivas convencionales.



- Система для фрезерования плоскости с двухсторонними квадратными пластинами с 8-ю кромками.
- 5 различных режущих геометрий в комбинации с 5ю твёрдыми сплавами делает возможным их применение для широкого спектра задач.
- Специальная аркообразная геометрии режущей кромки позволяет существенно понизить режущее усилие, система Double4Face даёт возможность работать на станках с ограниченной мощностью, так и замену общеприменяемых позитивных пластин.

HOLDERS

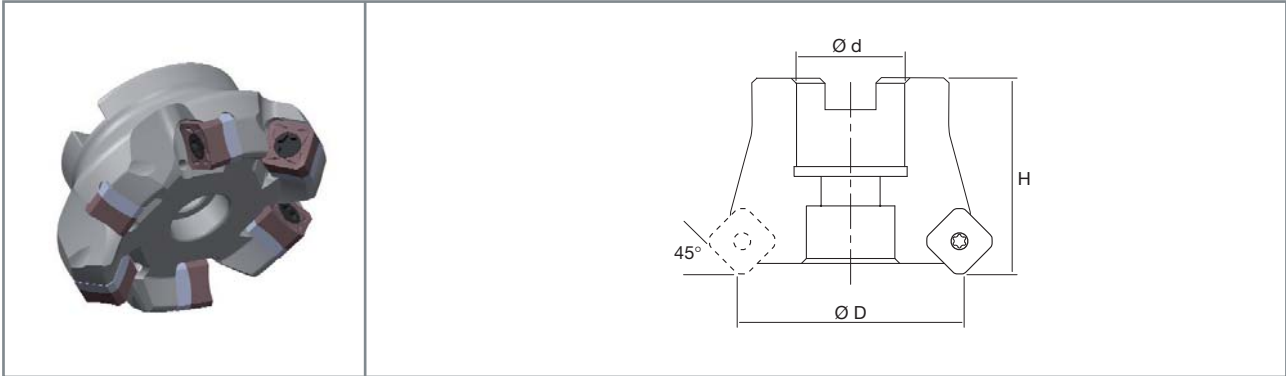

SN□X	DESCRIPTION	STOCK	DIMENSIONS				✓	← TORQUE Nm			← TORQUE Nm				
			ØD	Z	Ød	H		NT-SH009	NT-SR009	NT-WR040	NT-ST029	NT-FTB15			
SNEX1205 SNMX1205	NT-SX12H	D050-F22-Z4	●	50	4	22	40	✓	NT-SH009	NT-SR009	NT-WR040	7.0	NT-ST029	NT-FTB15	3.5
		D050-F22-Z5	●	50	5	22	40	✓	NT-SH009	NT-SR009	NT-WR040	7.0	NT-ST029	NT-FTB15	3.5
		D063-F22-Z5	●	63	5	22	40	✓	NT-SH009	NT-SR009	NT-WR040	7.0	NT-ST029	NT-FTB15	3.5
		D063-F22-Z6	●	63	6	22	40	✓	NT-SH009	NT-SR009	NT-WR040	7.0	NT-ST029	NT-FTB15	3.5
		D080-F27-Z6	●	80	6	27	50	✓	NT-SH009	NT-SR009	NT-WR040	7.0	NT-ST029	NT-FTB15	3.5
		D080-F27-Z7	●	80	7	27	50	✓	NT-SH009	NT-SR009	NT-WR040	7.0	NT-ST029	NT-FTB15	3.5
		D080-F27-Z8	●	80	8	27	50	✓	NT-SH009	NT-SR009	NT-WR040	7.0	NT-ST029	NT-FTB15	3.5
		D100-F32-Z7	●	100	7	32	50	✓	NT-SH009	NT-SR009	NT-WR040	7.0	NT-ST029	NT-FTB15	3.5
		D100-F32-Z8	●	100	8	32	50	✓	NT-SH009	NT-SR009	NT-WR040	7.0	NT-ST029	NT-FTB15	3.5
		D100-F32-Z9	●	100	9	32	50	✓	NT-SH009	NT-SR009	NT-WR040	7.0	NT-ST029	NT-FTB15	3.5
		D125-F40-Z10	●	125	10	40	63	✓	NT-SH009	NT-SR009	NT-WR040	7.0	NT-ST029	NT-FTB15	3.5
		D160-F40-Z12	●	160	12	40	63	✓	NT-SH009	NT-SR009	NT-WR040	7.0	NT-ST029	NT-FTB15	3.5

● stock standard

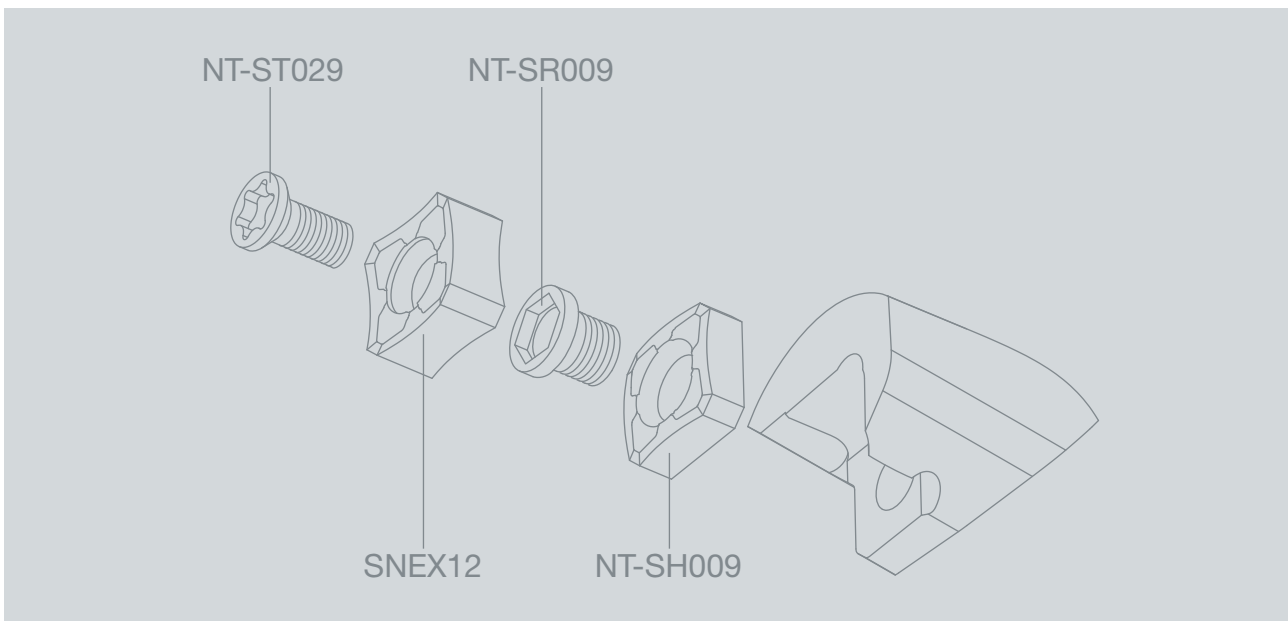

DOUBLE4FACE SERIES

INSERTS

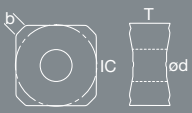
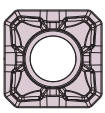
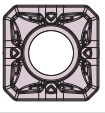
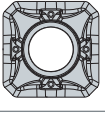
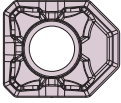
DESCRIPTION						HC					HW				
		IC	T	b	Ød	JP5520	JP5530	JP9535	JC7515	JP7525	JU6520				
SC	 SNEX 1205ANEN-SC	12.70	6.35	2.20	5.90	●	●	★	●	●					
GP	SNEX 1205ANEN-GP	12.70	6.35	2.20	5.90	●	●	★	●	●					
	SNMX 1205ANEN-GP	12.70	6.35	2.20	5.90	★									
TE	 SNEX 1205ANSN-TE	12.70	6.35	2.20	5.90	●	●		●	●					
AL	 POLISHED SNEX 1205ANFN-AL	12.70	6.35	2.20	5.90						●				
WU WIPER	 SNEX 1205-WU	12.70	6.35	5.60	5.90	●	●		●	●					

● stock standard; ★ upcoming introduction

HC: coated carbide

HW: uncoated carbide

JP: PVD coating

JC: CVD coating

JU: uncoated

GRADES APPLICATION CHART

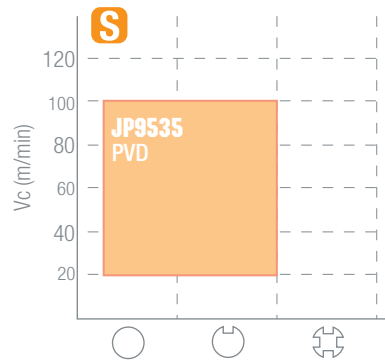
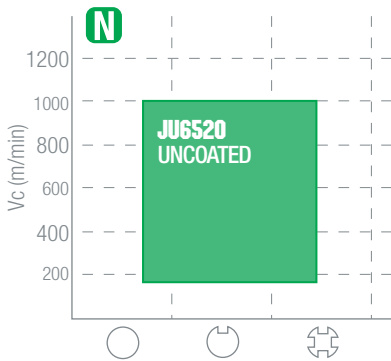
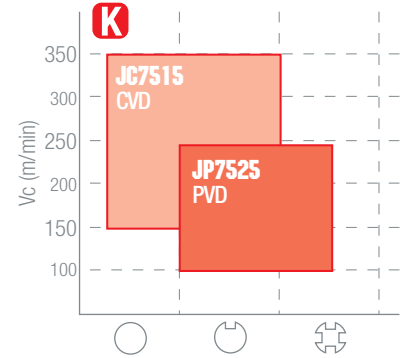
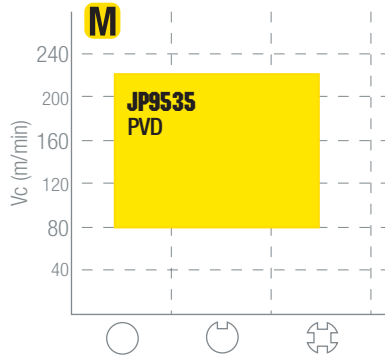
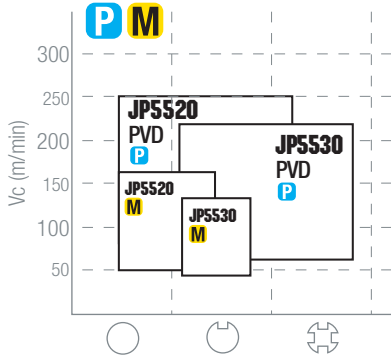

CHIPBREAKERS APPLICATION CHART

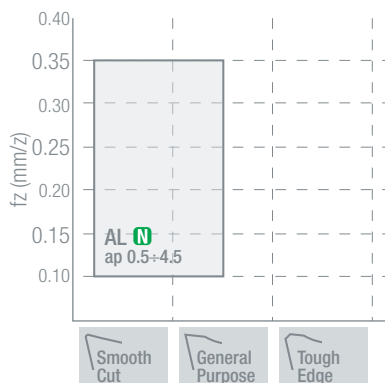
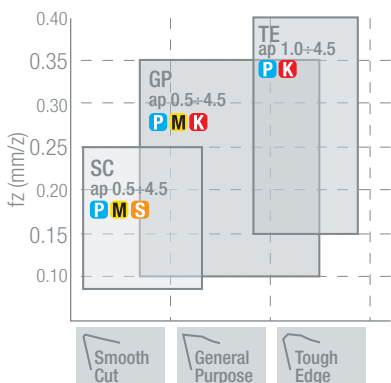

DOUBLE4FACE SERIES

WIPER APPLICATION CHART

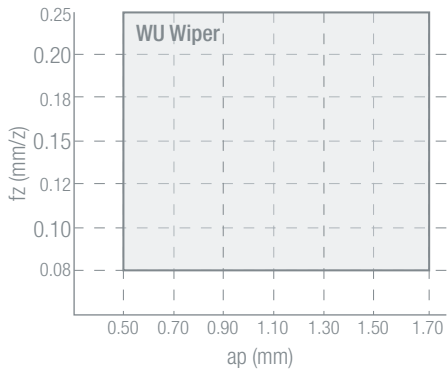

WIPER INSTALLATION

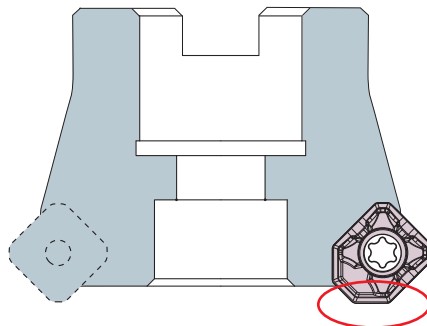

- The wiper insert must be mounted face towards the centre of the holder (see picture)
- WU style inserts feature 2 cutting edges (one on each side)
- Only 1 wiper insert per setup



- Installare l'inserto wiper rivolto verso il centro della fresa (vedere figura).
- La geometria WU ha 2 taglienti utilizzabili (uno per ogni lato)
- Installare un solo inserto wiper sul corpo fresa.



- Befestigen Sie die Wendeschneidplatte WIPER gegenüber der Mitte des Werkzeugs (siehe Abbildung).
- Die Geometrie WU hat zwei nutzbare Schneiden (eine pro Seite).
- Befestigen Sie nur eine Wendeschneidplatte WIPER auf den Schneidkörper



- Installer la plaquette wiper en face du centre de la fraise (voir photo).
- La géométrie WU a 2 arêtes utilisables (une pour chaque côté).
- Installer une seule plaquette wiper sur le corps d'outil.



- Instalar el inserto wiper frente al centro de la herramienta (ver figura).
- La geometría WU tiene dos filos útiles (uno por cada lado).
- Instalar un solo inserto wiper en el cuerpo fresa.



- Устанавливайте пластину wiper в направлении к центру фрезы (см. рисунок).
- Пластины геометрии WU обладают 2мя режущими кромками (одна на каждую сторону).
- Только одну пластину wiper устанавливайте на фрезу.

CUTTING SPEED (Vc m/min)

Gr.	MATERIAL		
P1	Free cutting steel and structural steel	Rm < 500 N/mm ²	(9SMn28 / 1.0715 / AVP)
P2	Carbon steel and low alloy steel	Rm 500-700 N/mm ²	(C40 / 1.0511)
P3	Medium alloy steel and heat treated steel	Rm 600-800 N/mm ²	(42CrMo4 / 1.7225)
P4	High alloy steel	Rm 800-1000 N/mm ²	(100Cr6 / 1.3505)
P5	Tool steel	Rm 900-1200 N/mm ²	(X210Cr12 / 1.2080 / K100)
P6	High tensile strength steel	Rm 1200-1600 N/mm ²	(X2NiCrMo18.9.5 / 1.6358 / W720)
M1	Ferritic stainless steel	Rm 400-700 N/mm ²	(X40Cr13 / 1.4034 / AISI420)
M2	Austenitic stainless steel (good machinability)	Rm 500-750 N/mm ²	(X5CrNi18.10 / 1.4301 / AISI304)
M3	Austenitic stainless steel (medium machinability)	Rm 550-850 N/mm ²	(X2CrNiMo18.12 / 1.4435 / AISI316L)
M4	Martensitic stainless steel	Rm 650-950 N/mm ²	(X2CrNiMoN25.7.4 / 1.4410 / Super Duplex)
M5	PH stainless steel	Rm 800-1250 N/mm ²	(X5CrNiNb16.4 / 1.4542 / 17-4PH)
K1	Grey cast iron	HB 150-250	(GG-25 / 0.6025)
K2	Nodular cast iron	HB 150-350	(GGG-50 / 0.7050)
K3	Austenitic cast iron	HB 120-260	(GGL-NiCr20.2 / 0.6660)
K4	ADI cast iron	HB 250-500	(GJS-1000-5 / ADI 1000)
N1	Aluminium alloys < 12% Si		(AlMgSi0.5 / 3.3206)
N2	Aluminium alloys > 12% Si		(AlSi12 / 3.2582)
N3	Copper alloys		(E-Cu57 / 2.0060)
N4	Brass alloys and bronze alloys		(CuZn20Al2 / 2.0460)
S1	Heat resistant super alloys HRSA (good machinability)	HRC < 25	(NiCr17Mo17FeW / 2.4802 / Hastelloy)
S2	Heat resistant super alloys HRSA (medium machinability)	HRC 25-35	(NiCr20Ti / 2.4630 / Nimonic 80)
S3	Heat resistant super alloys HRSA (low machinability)	HRC 35-45	(NiCr19Fe19NbMo / 2.4668 / Inconel 718)
S4	Low alloy titanium		(Ti99.6 / 3.7055 / Titanium grade 3)
S5	High alloy titanium		(Ti5Al2.5Sn / 3.7115 / Titanium grade 6)

Gr.	JP5520	JP5530	JP9535	JC7515	JP7525	JU6520
P1	200 ÷ 250	180 ÷ 230				
P2	160 ÷ 220	150 ÷ 210				
P3	140 ÷ 200	120 ÷ 180				
P4	120 ÷ 160	100 ÷ 150				
P5	100 ÷ 140	80 ÷ 130				
P6	80 ÷ 120	60 ÷ 110				
M1	100 ÷ 160	90 ÷ 150	120 ÷ 220			
M2	80 ÷ 140	80 ÷ 130	100 ÷ 200			
M3	60 ÷ 120	60 ÷ 100	120 ÷ 180			
M4			90 ÷ 150			
M5			80 ÷ 140			
K1				200 ÷ 350	150 ÷ 240	
K2				180 ÷ 280	120 ÷ 200	
K3				140 ÷ 200	100 ÷ 150	
K4				120 ÷ 180		
N1						400 ÷ 1000
N2						300 ÷ 600
N3						300 ÷ 500
N4						200 ÷ 400
S1			30 ÷ 60			
S2			30 ÷ 50			
S3			20 ÷ 40			
S4			50 ÷ 100			
S5			40 ÷ 80			



DOUBLE 3GON SERIES

Double up your productivity on shouldering.

ISO

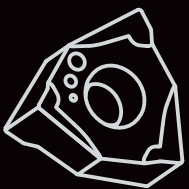

6 edges

nikkoTOOLS

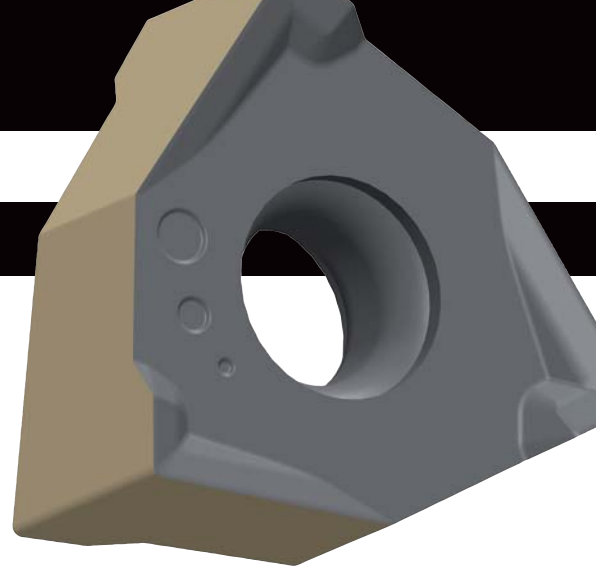

DOUBLE 3GON SERIES

Double up your productivity on shouldering.



- Milling system for 90° shouldering based on double-sided trigonal inserts.
- High reliability thanks to the greater thickness of WNEX inserts.
- Massive savings are enabled by the 6-cutting edges insert design.
- High versatility: 2 cutting geometries combined with 4 different carbide grades for a wide range of applications.



- Sistema di fresatura con inserti trigonali bilaterali per operazioni di spallamento retto.
- Affidabile: grazie all'elevato spessore degli inserti WNEX.
- Economico: costo tagliente molto vantaggioso grazie ai 6 posizionamenti.
- Versatile: 2 geometrie di taglio e 4 gradi di metallo duro garantiscono un vasto campo applicativo.



- Frässystem für 90 ° Eckfräsen basierend auf negative trigonale WSP.
- Hohe Zuverlässigkeit, dank der größeren Dicke der WNEX WSP.
- Große Einsparungen werden durch die 6-Schneiden erreicht.
- Hohe Vielseitigkeit: 2 Schneidgeometrien kombiniert mit 4 verschiedenen Hartmetallsorten für eine Vielzahl von Anwendungen.



- Système de fraisage avec plaquettes triangulaires bilatérales pour des opérations d'épaulement droit.
- Fiable: grâce à l'épaisseur de la plaquette WNEX.
- Economique: coût par arrête très avantageux grâce aux 6 cotés interchangeables.
- Polyvalent: 2 géométries de coupe combinées à 4 nuances de carbure garantissent un large champ d'application.



- Sistema de fresado con placas trigonales de doble cara para operaciones en escuadra.
- Fiable: gracias al espesor de las placas WNEX.
- Económico: costo por corte muy ventajoso gracias a la 6 posiciones.
- 2 geometrías de corte y 4 grados de metal duro ofrecen una amplia gama de aplicaciones.



- Треугольные двухсторонние пластины для фрезерования по уступу с углом 90°.
- Повышенная надежность благодаря большей толщине WNEX пластин.
- Значительная экономия благодаря наличию 6-ти режущих кромок.
- Широкая область применения обеспечивается наличием 2-х режущих геометрий и 4-мя сплавами.

HOLDERS

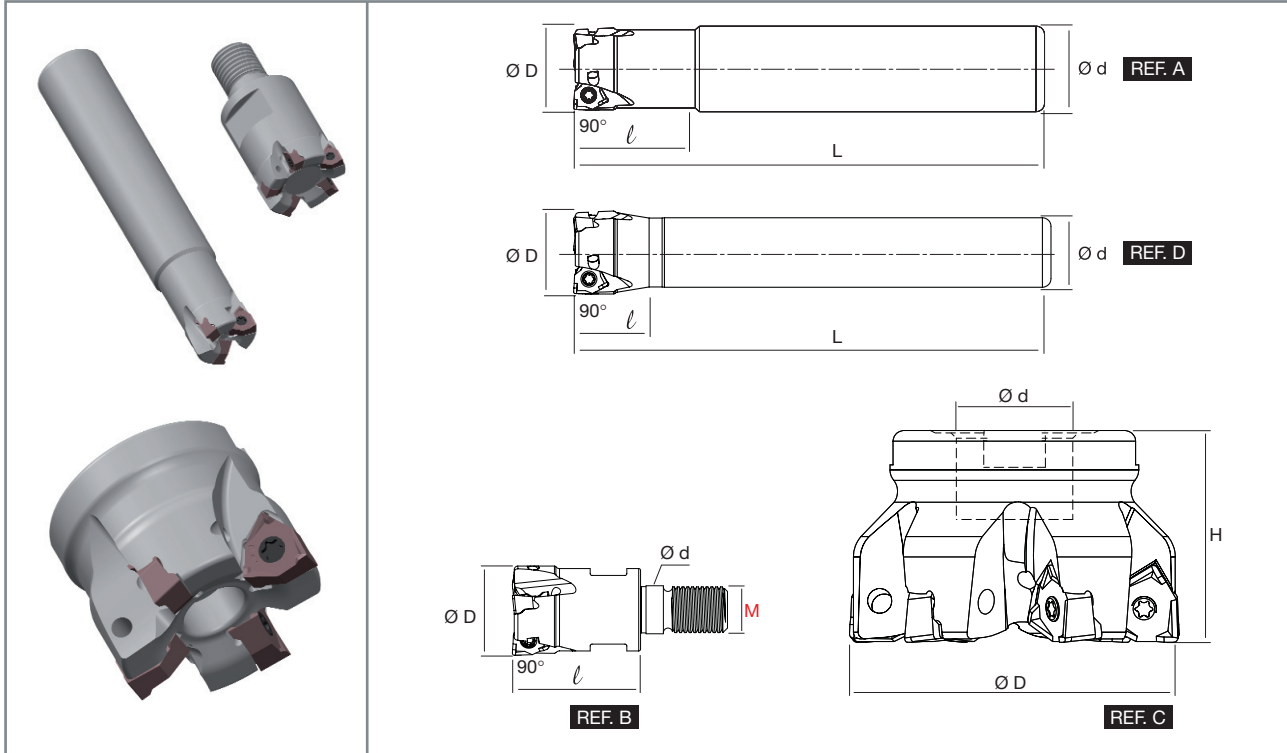

WNEX	DESCRIPTION	STOCK	DIMENSIONS							REF	REF. A	REF. B	REF. C	TORQUE Nm				
			ØD	Z	Ød	L	l	H										
WNEX0403	NT-WX04H	D020-M10-Z3	●	20	3	10.5	-	28	-	B	✓	NT-ST018	NT-FTB08	1.2				
		D020-S16-Z3	●	20	3	16	110	20	-	D	✓	NT-ST018	NT-FTB08	1.2				
		D020-S20-Z3	●	20	3	20	110	28	-	A	✓	NT-ST018	NT-FTB08	1.2				
		D025-M12-Z4	●	25	4	12.5	-	30	-	B	✓	NT-ST018	NT-FTB08	1.2				
		D025-S20-Z4	●	25	4	20	120	22	-	D	✓	NT-ST018	NT-FTB08	1.2				
		D025-S25-Z4	●	25	4	25	120	30	-	A	✓	NT-ST018	NT-FTB08	1.2				
		D032-M16-Z5	●	32	5	16.5	-	40	-	B	✓	NT-ST018	NT-FTB08	1.2				
		D032-S25-Z5	●	32	5	25	130	25	-	D	✓	NT-ST018	NT-FTB08	1.2				
		D032-S32-Z5	●	32	5	32	130	40	-	A	✓	NT-ST018	NT-FTB08	1.2				
		D040-F16-Z7	●	40	7	16	-	-	40	C	✓	NT-ST018	NT-FTB08	1.2				
D050-F22-Z9	●	50	9	22	-	-	40	C	✓	NT-ST018	NT-FTB08	1.2						
WNEX0806	NT-WX08H	D050-F22-Z4	●	50	4	22	-	-	40	C	✓	NT-ST017	NT-FTB15	3.5				
		D050-F22-Z5	●	50	5	22	-	-	40	C	✓	NT-ST017	NT-FTB15	3.5				
		D063-F22-Z6	●	63	6	22	-	-	40	C	✓	NT-ST017	NT-FTB15	3.5				
		D063-F22-Z7	●	63	7	22	-	-	40	C	✓	NT-ST017	NT-FTB15	3.5				
		D080-F27-Z7	●	80	7	27	-	-	50	C	✓	NT-ST017	NT-FTB15	3.5				
		D080-F27-Z9	●	80	9	27	-	-	50	C	✓	NT-ST017	NT-FTB15	3.5				
		D100-F32-Z8	●	100	8	32	-	-	50	C	✓	NT-ST017	NT-FTB15	3.5				
		D100-F32-Z11	●	100	11	32	-	-	50	C	✓	NT-ST017	NT-FTB15	3.5				
		D125-F40-Z11	●	125	11	40	-	-	63	C	✓	NT-ST017	NT-FTB15	3.5				
D160-F40-Z12	●	160	12	40	-	-	63	C	✓	NT-ST017	NT-FTB15	3.5						

● stock standard

DOUBLE3GON SERIES

INSERTS

DESCRIPTION								HC							
		IC	T	r	b	Ød	JP8525	JC8530	JP9525	JC7530					
GP	WNEX 040304R-GP	6.72	3.30	0.4	0.90	3.10	●	●	●	●					
	WNEX 080608R-GP	12.50	6.45	0.8	1.50	4.40	●	●	●	●					
TE	WNEX 080608R-TE	12.50	6.45	0.8	1.50	4.40	●	●	●	●					

● stock standard

HC: coated carbide

JP: PVD coating

JC: CVD coating

GRADES APPLICATION CHART

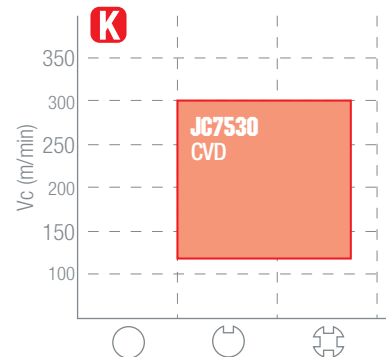
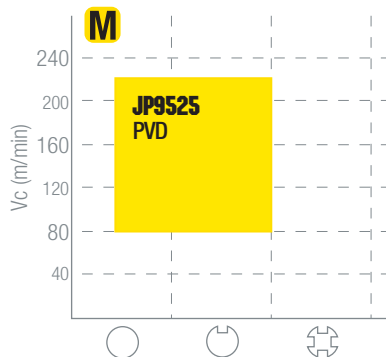
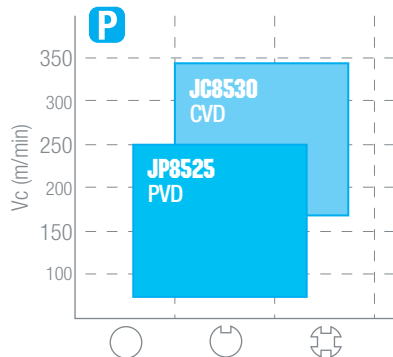

CHIPBREAKERS APPLICATION CHART

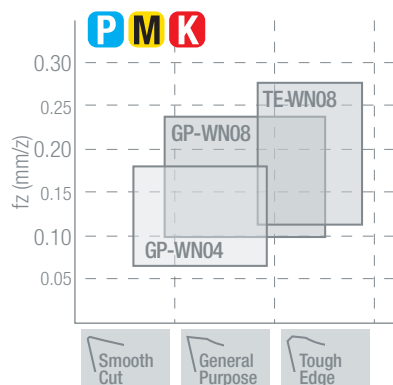

INSERTS APPLICATION CHART

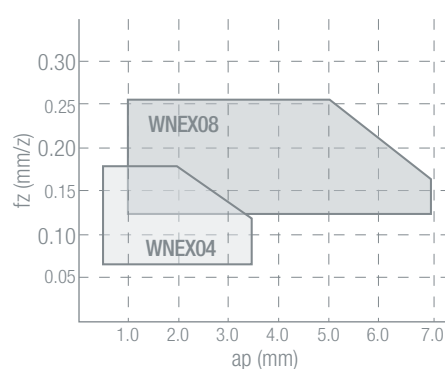

CUTTING SPEED (Vc m/min)

Gr.	MATERIAL		JP8525	JC8530	JP9525	JC7530
P1	Free cutting steel and structural steel	Rm < 500 N/mm ² (9SMn28 / 1.0715 / AVP)	200 ÷ 250	260 ÷ 330		
P2	Carbon steel and low alloy steel	Rm 500-700 N/mm ² (C40 / 1.0511)	170 ÷ 210	220 ÷ 280		
P3	Medium alloy steel and heat treated steel	Rm 600-800 N/mm ² (42CrMo4 / 1.7225)	140 ÷ 170	180 ÷ 220		
P4	High alloy steel	Rm 800-1000 N/mm ² (100Cr6 / 1.3505)	110 ÷ 140	140 ÷ 180		
P5	Tool steel	Rm 900-1200 N/mm ² (X210Cr12 / 1.2080 / K100)	70 ÷ 100	100 ÷ 120		
P6	High tensile strength steel	Rm 1200-1600 N/mm ² (X2NiCrMo18.9.5 / 1.6358 / W720)	60 ÷ 80	80 ÷ 100		
M1	Ferritic stainless steel	Rm 400-700 N/mm ² (X40Cr13 / 1.4034 / AISI420)			130 ÷ 220	
M2	Austenitic stainless steel (good machinability)	Rm 500-750 N/mm ² (X5CrNi18.10 / 1.4301 / AISI304)			110 ÷ 180	
M3	Austenitic stainless steel (medium machinability)	Rm 550-850 N/mm ² (X2CrNiMo18.12 / 1.4435 / AISI316L)			90 ÷ 150	
M4	Martensitic stainless steel	Rm 650-950 N/mm ² (X2CrNiMoN25.7.4 / 1.4410 / Super Duplex)			80 ÷ 140	
M5	PH stainless steel	Rm 800-1250 N/mm ² (X5CrNiNb16.4 / 1.4542 / 17-4PH)			70 ÷ 120	
K1	Grey cast iron	HB 150-250 (GG-25 / 0.6025)				160 ÷ 280
K2	Nodular cast iron	HB 150-350 (GGG-50 / 0.7050)				140 ÷ 240
K3	Austenitic cast iron	HB 120-260 (GGL-NiCr20.2 / 0.6660)				120 ÷ 160
K4	ADI cast iron	HB 250-500 (GJS-1000-5 / ADI 1000)				80 ÷ 140

HIGH
FEED

HF4P^{PLUS} SERIES

Speed up your performance.

ISO

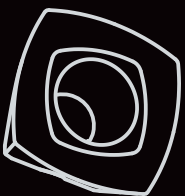

4 edges

nixkoTOOLS

HF4PLUS SERIES

HOLDERS

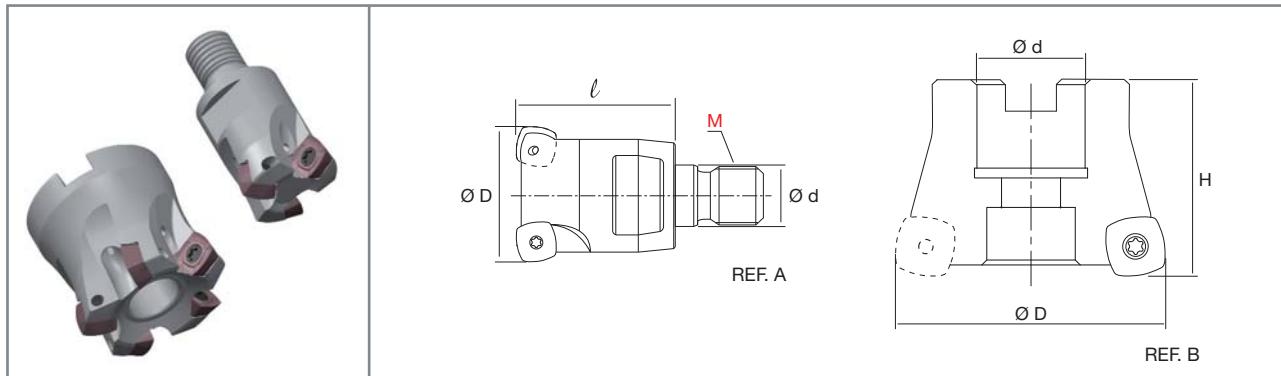

SDMT	DESCRIPTION	STOCK	DIMENSIONS						REF	✓	M	✓	TORQUE Nm				
			ØD	Z	Ød	l	H										
SDMT1205	NT-SD12HF D032-M16-Z2	●	32	2	16.5	43	-	A	✓	NT-ST024	NT-FTB15	3.50					
	D035-M16-Z3	●	35	3	16.5	43	-	A	✓	NT-ST024	NT-FTB15	3.50					
	D040-M16-Z4	●	40	4	16.5	43	-	A	✓	NT-ST024	NT-FTB15	3.50					
	D042-M16-Z4	●	42	4	16.5	43	-	A	✓	NT-ST024	NT-FTB15	3.50					
	D042-F16-Z4	●	42	4	16	-	40	B	✓	NT-ST024	NT-FTB15	3.50					
	D050-F22-Z4	●	50	4	22	-	50	B	✓	NT-ST024	NT-FTB15	3.50					
	D050-F22-Z5	●	50	5	22	-	50	B	✓	NT-ST024	NT-FTB15	3.50					
	D052-F22-Z4	●	52	4	22	-	50	B	✓	NT-ST024	NT-FTB15	3.50					
	D052-F22-Z5	●	52	5	22	-	50	B	✓	NT-ST024	NT-FTB15	3.50					
	D063-F22-Z4	●	63	4	22	-	50	B	✓	NT-ST024	NT-FTB15	3.50					
	D063-F27-Z4	●	63	4	27	-	50	B	✓	NT-ST024	NT-FTB15	3.50					
	D063-F22-Z5	●	63	5	22	-	50	B	✓	NT-ST024	NT-FTB15	3.50					
	D063-F27-Z5	●	63	5	27	-	50	B	✓	NT-ST024	NT-FTB15	3.50					
	D066-F27-Z6	●	66	6	27	-	50	B	✓	NT-ST024	NT-FTB15	3.50					
	D080-F27-Z6	●	80	6	27	-	50	B	✓	NT-ST024	NT-FTB15	3.50					
	D080-F27-Z7	●	80	7	27	-	50	B	✓	NT-ST024	NT-FTB15	3.50					

● stock standard

INSERTS

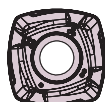
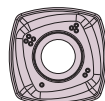
DESCRIPTION	IC				HC							
	IC	T	r	Ød	JP5520	JP5530	JP9535	JP7525				
 SDMT 120512R-GP	12.70	5.56	1.2	4.40	●	●	★	●				
 SDMT 120512R-TE	12.70	5.56	1.2	4.40	●	●						

● stock standard; ★ upcoming introduction

HC: coated carbide

JP: PVD coating

GRADES APPLICATION CHART

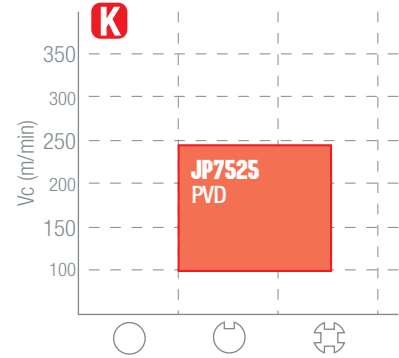
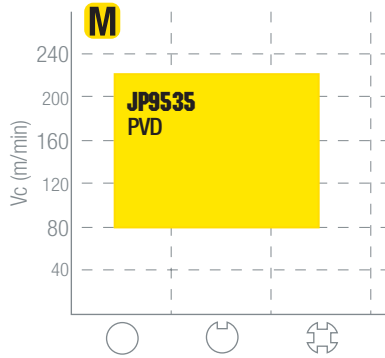
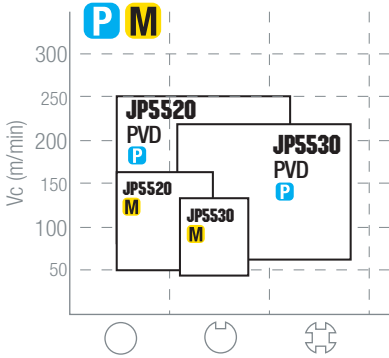

CHIPBREAKERS APPLICATION CHART

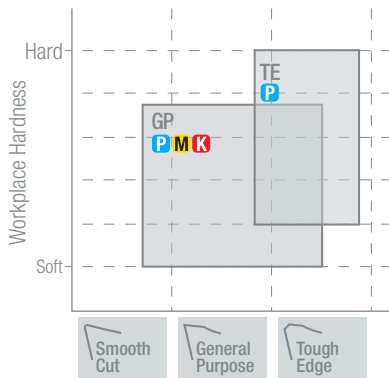

INSERTS APPLICATION CHART

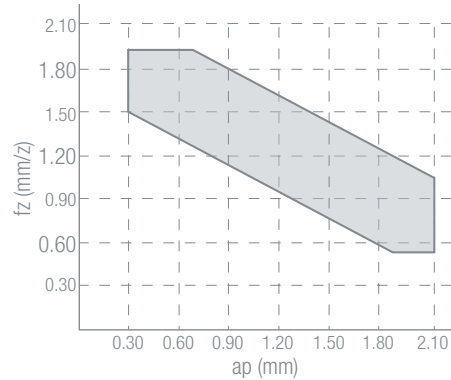

IMPORTANT NOTICE FOR CNC PROGRAMMING

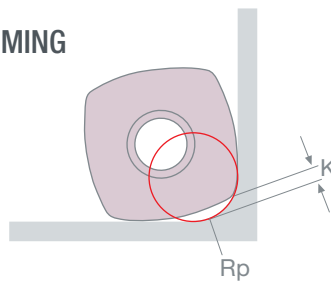

• Theoretical radius for CNC programming $R_p=4.0\text{mm}$.
• Uncut portion $K=0.85\text{mm}$

• Valore del raggio teorico per la programmazione CNC $R_p=4.0\text{mm}$.
• Area non lavorata $K=0.85\text{mm}$.

• Theoretischer Radius für CNC-Programmierung $R_p=4.0\text{mm}$.
• Nicht bearbeiteter Bereich $K=0.85\text{mm}$.

• Valeur du rayon théorique pour la programmation CNC $R_p=4.0\text{mm}$
• Zone non usinée $K=0.85\text{mm}$

• Valor del radio teórico para la programación CNC $R_p=4.0\text{mm}$.
• Área no procesada $K=0.85\text{mm}$.

• Теоретическое значение радиуса для программирования на ЧПУ $R_p=4.0\text{mm}$.
• Необработанная область $K=0.85\text{mm}$.

HF4PLUS SERIES

CUTTING SPEED (Vc m/min)

Gr.	MATERIAL		JP5520	JP5530	JP9535	JP7525
P1	Free cutting steel and structural steel	Rm < 500 N/mm ² (9SMn28 / 1.0715 / AVP)	200 ÷ 250	180 ÷ 230		
P2	Carbon steel and low alloy steel	Rm 500-700 N/mm ² (C40 / 1.0511)	160 ÷ 220	150 ÷ 210		
P3	Medium alloy steel and heat treated steel	Rm 600-800 N/mm ² (42CrMo4 / 1.7225)	140 ÷ 200	120 ÷ 180		
P4	High alloy steel	Rm 800-1000 N/mm ² (100Cr6 / 1.3505)	120 ÷ 160	100 ÷ 150		
P5	Tool steel	Rm 900-1200 N/mm ² (X210Cr12 / 1.2080 / K100)	100 ÷ 140	80 ÷ 130		
P6	High tensile strength steel	Rm 1200-1600 N/mm ² (X2NiCrMo18.9.5 / 1.6358 / W720)	80 ÷ 120	60 ÷ 110		
M1	Ferritic stainless steel	Rm 400-700 N/mm ² (X40Cr13 / 1.4034 / AISI420)	100 ÷ 160	90 ÷ 150	120 ÷ 220	
M2	Austenitic stainless steel (good machinability)	Rm 500-750 N/mm ² (X5CrNi18.10 / 1.4301 / AISI304)	80 ÷ 140	80 ÷ 130	100 ÷ 200	
M3	Austenitic stainless steel (medium machinability)	Rm 550-850 N/mm ² (X2CrNiMo18.12 / 1.4435 / AISI316L)	60 ÷ 120	60 ÷ 100	120 ÷ 180	
M4	Martensitic stainless steel	Rm 650-950 N/mm ² (X2CrNiMoN25.7.4 / 1.4410 / Super Duplex)			90 ÷ 150	
M5	PH stainless steel	Rm 800-1250 N/mm ² (X5CrNiNb16.4 / 1.4542 / 17-4PH)			80 ÷ 140	
K1	Grey cast iron	HB 150-250 (GG-25 / 0.6025)				150 ÷ 240
K2	Nodular cast iron	HB 150-350 (GGG-50 / 0.7050)				120 ÷ 200
K3	Austenitic cast iron	HB 120-260 (GGL-NiCr20.2 / 0.6660)				100 ÷ 150

GENERAL SUGGESTIONS

		Ø32	Ø35	Ø40	Ø42	Ø50	Ø52	Ø63	Ø66	Ø80
RAMPING	α max (maximum ramping angle)	4°	3.6°	3°	3°	2.7°	2.6°	1.5°	1.3°	1°
	fz (mm/z)	reduced by 25%								
HELICAL	Ømin-Ømax (range of Ø machinable)	42-60	48-66	58-76	62-80	78-96	82-100	104-122	110-128	138-156
	ap max (maximum depth for each revolution)	1 mm								
PEEK MILLING	fz (mm/z)	reduced by 50%								
	ap max (maximum drilling depth)	1 mm								
	L (min length to produce a flat surface after drilling)	10	13	18	20	28	30	41	44	58
PLUNGING	ae max	8 mm								
	fz (mm/z)	0.06÷0.15 mm/z								

ADVANCED MILLING SERIES

The highest technology for milling.

ISO



- silicon nitride
- mixed ceramic
- reinforced ceramic
- solid PCBN

nixkoTOOLS

ADVANCED MILLING SERIES

75° HOLDERS for double-sided square inserts

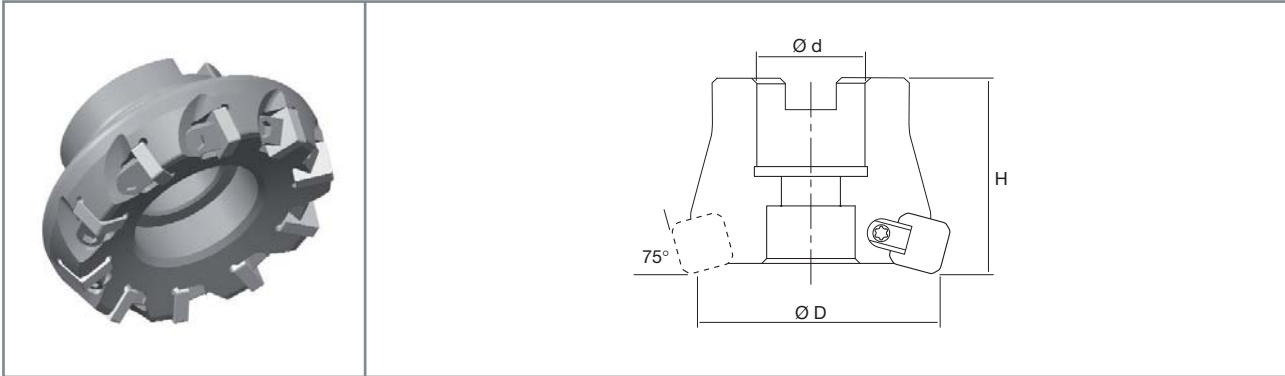

SN□□	DESCRIPTION	STOCK	DIMENSIONS				✕				TORQUE Nm			
			ØD	Z	Ød	H								
SNCN1204	NT-SN12-75° D050-F22-Z5	●	50	5	22	40	✕	NT-WD070	NT-SC060	NT-WR030	7.0			
SNEN1204	D063-F22-Z6	●	63	6	22	40	✕	NT-WD070	NT-SC060	NT-WR030	7.0			
SNGX1204	D080-F27-Z8	●	80	8	27	50	✕	NT-WD070	NT-SC060	NT-WR030	7.0			
SNMN1204	D100-F32-Z10	●	100	10	32	50	✕	NT-WD070	NT-SC060	NT-WR030	7.0			
	D125-F40-Z12	●	125	12	40	63	✕	NT-WD070	NT-SC060	NT-WR030	7.0			

● stock standard

APPLICABLE INSERTS

DESCRIPTION																		
	IC	T	r	b	HC	CN					CR		BH					
					NAC200	NSN350	NSN400	NSN450	NSA600	NSA650	NWR700	NWR750	NBS5050	NBS9000				
GP	SNEN 120412-GP	12.70	4.76	1.2	-													
	SNGN 120408-GP	12.70	4.76	0.8	-	○		●		○	○	○	○				●	
	120412-GP	12.70	4.76	1.2	-	○		●	●	○	○	○	○				●	
	120416-GP	12.70	4.76	1.6	-	○		○	○	○	○	○	○					○
	SNMN 120416-GP	12.70	4.76	1.6	-			●										
EN-GP	SNCN 1204EN-GP	12.70	4.76	-	1.3			●										
	SNEN 1204EN-GP	12.70	4.76	-	1.3												★	
GS	SNGX 120412-GS	12.70	4.76	1.2	-			●										

● stock standard; ○ non stock standard; ★ upcoming introduction

CM: mixed ceramic Al₂O₃+TiCN
 CN: silicon nitride S₃N₄
 CR: reinforced ceramic Al₂O₃+SiC
 BH: PCBN with high CBN content

88° HOLDERS for double-sided square inserts

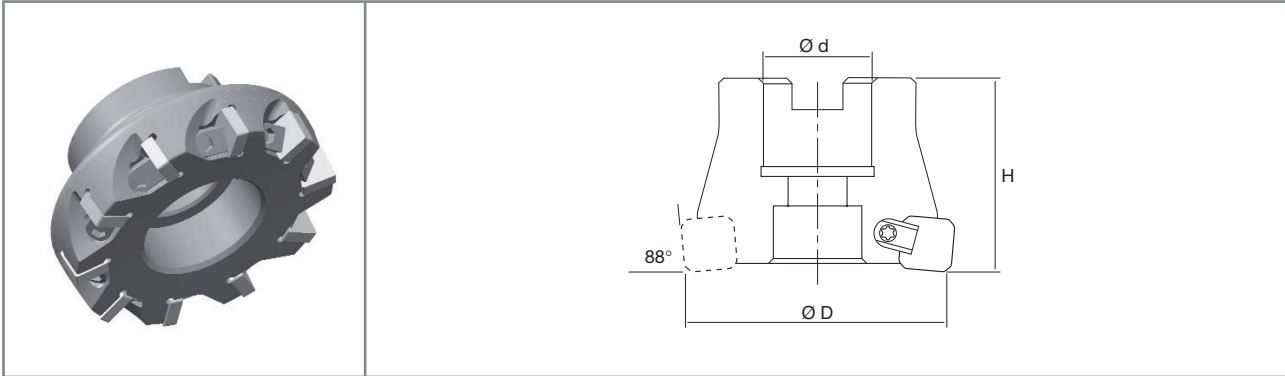

SN□□	DESCRIPTION	STOCK	DIMENSIONS				✕				TORQUE Nm			
			ØD	Z	Ød	H								
SNCN1204	NT-SN12-88° D063-F22-Z6	●	63	6	22	40	✕	NT-WD070	NT-SC060	NT-WR030	7.0			
SNEN1204	D080-F27-Z8	●	80	8	27	50	✕	NT-WD070	NT-SC060	NT-WR030	7.0			
SNGX1204	D100-F32-Z10	●	100	10	32	50	✕	NT-WD070	NT-SC060	NT-WR030	7.0			
SNMN1204	D125-F40-Z12	●	125	12	40	63	✕	NT-WD070	NT-SC060	NT-WR030	7.0			

● stock standard

APPLICABLE INSERTS

DESCRIPTION					HC		CN					CR		BH	
	IC	T	r	b	NAC200	NSN350	NSN400	NSN450	NSA600	NSA650	NWR700	NWR750	NBS5050	NBS9000	
GP	SNCN 120412-GP	12.70	4.76	1.2	-								●		
	SNGN 120408-GP	12.70	4.76	0.8	-	○		●		○	○	○	○		●
	120412-GP	12.70	4.76	1.2	-	○		●	●	○	○	○	○		●
	120416-GP	12.70	4.76	1.6	-	○		○	○	○	○	○	○		○
	SNMN 120416-GP	12.70	4.76	1.6	-			●							
HN-GP	SNCN 1204HN-GP	12.70	4.76	-	1.8			●							
	SNEN 1204HN-GP	12.70	4.76	-	1.8								★		
GS	CHIPBREAKER SNGX 120412-GS	12.70	4.76	1.2	-			●							

● stock standard; ○ non stock standard; ★ upcoming introduction

CM: mixed ceramic Al₂O₃+TiCN
 CN: silicon nitride S₃N₄
 CR: reinforced ceramic Al₂O₃+SiC
 BH: PCBN with high CBN content

ADVANCED MILLING SERIES

90° HOLDERS for tangential inserts

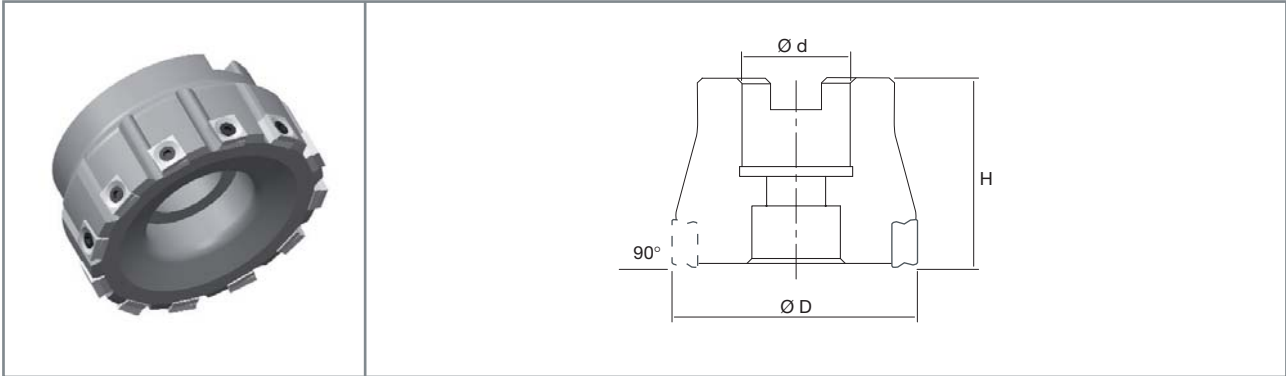

SPHX	DESCRIPTION	STOCK	DIMENSIONS				✕	NT-ST027	NT-FT15	TORQUE Nm				
			ØD	Z	Ød	H								
SPHX1205	NT-SP12-TAN D050-F22-Z5	●	50	5	22	50	✕	NT-ST027	NT-FT15	3.5				
	D063-F22-Z7	●	63	7	22	50	✕	NT-ST027	NT-FT15	3.5				
	D080-F27-Z8	●	80	8	27	50	✕	NT-ST027	NT-FT15	3.5				
	D100-F32-Z12	●	100	12	32	50	✕	NT-ST027	NT-FT15	3.5				
	D125-F40-Z15	●	125	15	40	50	✕	NT-ST027	NT-FT15	3.5				

● stock standard

APPLICABLE INSERTS





DESCRIPTION					CN									
	IC	IC1	T	Ød	NSN350	NSN400								
 SPHX 1205PCTR-GP	11.67	11.33	5.50	5.10	○	●								

● stock standard

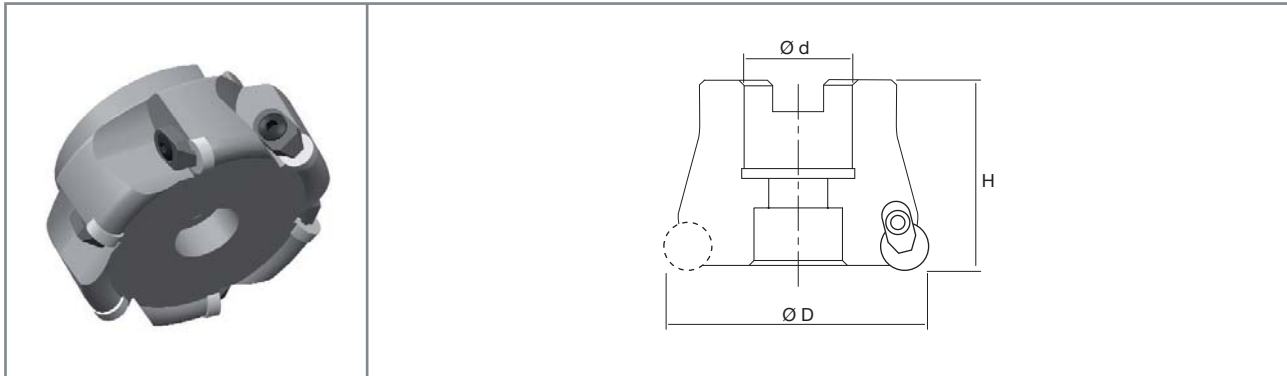
CN: silicon nitride S_3N_4



HOLDERS for round double-sided inserts



RNGN	DESCRIPTION	STOCK	DIMENSIONS				✕					TORQUE Nm			
			$\varnothing D$	Z	$\varnothing d$	H									
RNGN1204	NT-RN12	D050-F22-Z4	●	50	4	22	50	✕	NT-CS028	NT-ST028	NT-SG028	NT-WR030	7.0		
		D063-F22-Z4	●	63	4	22	50	✕	NT-CS028	NT-ST028	NT-SG028	NT-WR030	7.0		
		D080-F27-Z5	●	80	5	27	50	✕	NT-CS028	NT-ST028	NT-SG028	NT-WR030	7.0		
		D100-F32-Z6	●	100	6	32	50	✕	NT-CS028	NT-ST028	NT-SG028	NT-WR030	7.0		

● stock standard

APPLICABLE INSERTS

DESCRIPTION					CM	CN	CR		BH			
	IC	T	r	b	NAC200	NSA600	NSA650	NWR700	NWR750	NBS9000		
 RNGN 120400-GP	12.70	4.76	6.35	-	●	●	●	●	●	●		

● stock standard

CM: mixed ceramic Al_2O_3+TiCN
 CN: silicon nitride S_3N_4
 CR: reinforced ceramic Al_2O_3+SiC
 BH: PCBN with high CBN content

ADVANCED MILLING SERIES

PARAMETERS

Gr.	MATERIAL		
K1	Grey cast iron	HB 150-250	(GG-25 / 0.6025)
K2	Nodular cast iron	HB 150-350	(GGG-50 / 0.7050)
S1	Heat resistant super alloys (good machinability)	HRC < 25	(NiCr22Mo9Nb / 2.4856 / Inconel 625)
S2	Heat resistant super alloys (medium machinability)	HRC 25-35	(NiCr20Ti / 2.4630 / Nimonic 75)
S3	Heat resistant super alloys (low machinability)	HRC 35-45	(NiCr19Fe19Nb5Mo3 / 2.4668 / Inconel 718)
H1	Hardened general steel	HRC 50-56	(42CrMo4 / 1.7225)
H2	Hardened bearing steel	HRC 54-62	(100Cr6 / 1.3505)
H3	Hardened tool steel	HRC 60-65	(X100CrMoV5.1 / 1.2363)

Gr.	Grade		Vc m/min	ap (mm)	fz (mm/z)	NT-SM12-75°	NT-SM12-88°	NT-SP12-TAN	NT-RM12
K1	NAC series	DRY	200 ÷ 700	0.1 ÷ 0.5	0.08 ÷ 0.15	✓	✓		
	NSN series	DRY	600 ÷ 1000	1.0 ÷ 4.0	0.10 ÷ 0.25	✓	✓	✓	
	NBS series	DRY	800 ÷ 1500	1.0 ÷ 3.0	0.10 ÷ 0.30	✓	✓		
K2	NSN series	DRY	400 ÷ 700	1.0 ÷ 2.0	0.08 ÷ 0.20	✓	✓		
	NSA series	DRY	400 ÷ 700	1.0 ÷ 2.0	0.08 ÷ 0.20	✓	✓		
S1	NSA series	DRY	700 ÷ 1000	0.5 ÷ 2.0	0.10 ÷ 0.15				✓
S2	NSA series	DRY	500 ÷ 800	0.5 ÷ 2.0	0.08 ÷ 0.12				✓
S3	NSA series	DRY	400 ÷ 600	0.5 ÷ 2.0	0.05 ÷ 0.10				✓
H1	NAC series	DRY	80 ÷ 140	0.5 ÷ 1.0	0.05 ÷ 0.09				✓
	NWR series	DRY	120 ÷ 200	0.5 ÷ 1.0	0.07 ÷ 0.12				✓
	NBS series	DRY	200 ÷ 300	0.5 ÷ 1.0	0.07 ÷ 0.15				✓
H2	NAC series	DRY	60 ÷ 120	0.5 ÷ 1.0	0.04 ÷ 0.08				✓
	NWR series	DRY	100 ÷ 160	0.5 ÷ 1.0	0.06 ÷ 0.10				✓
	NBS series	DRY	150 ÷ 250	0.5 ÷ 1.0	0.06 ÷ 0.12				✓
H3	NAC series	DRY	40 ÷ 100	0.5 ÷ 1.0	0.04 ÷ 0.07				✓
	NWR series	DRY	60 ÷ 150	0.5 ÷ 1.0	0.05 ÷ 0.09				✓
	NBS series	DRY	100 ÷ 200	0.5 ÷ 1.0	0.05 ÷ 0.10				✓

GRADES APPLICATION CHART

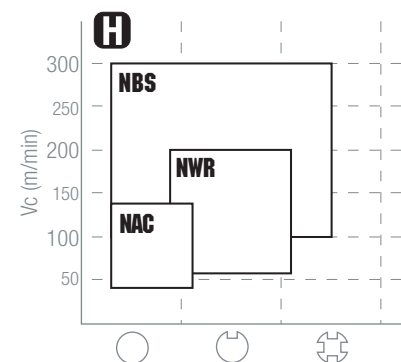
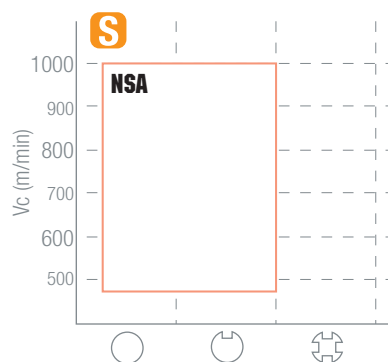
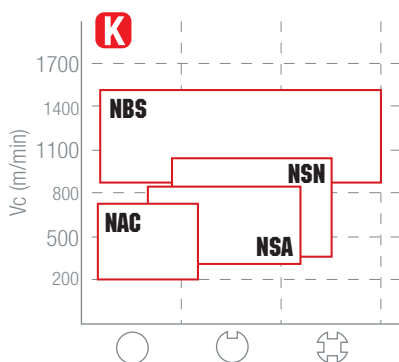

ROUND PLUS SERIES

The all-around solution for copying.

ISO

P

M

K

S

- R2.5 $\varnothing 9\div 17$
- R3.5 $\varnothing 16\div 35$
- R5.0 $\varnothing 20\div 52$
- R6.0 $\varnothing 42\div 80$
- R8.0 $\varnothing 63\div 125$



nixkoTOOLS

ROUNDPLUS SERIES

HOLDERS RD□□05 - RD□□07

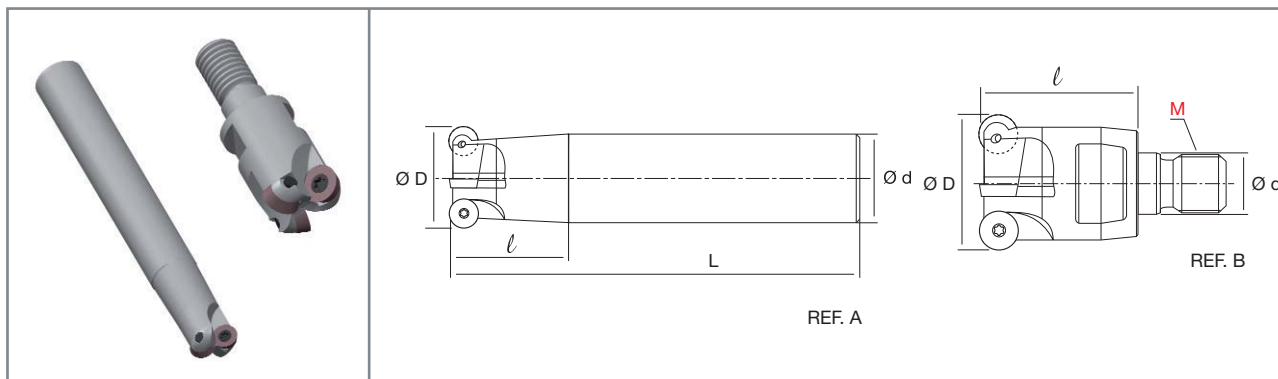

RD□□	DESCRIPTION	STOCK	DIMENSIONS					REF	🔧	🔩	🔧	TORQUE Nm					
			ØD	Z	Ød	L	l										
RDEW0501	NT-RD05	D009-S08-Z2-L100	●	9	2	8	100	12	A	×	NT-ST026	NT-FTB06	0.50				
		D010-S10-Z2-L100	●	10	2	10	100	18	A	×	NT-ST026	NT-FTB06	0.50				
		D011-S10-Z2-L100	●	11	2	10	100	15	A	×	NT-ST009	NT-FTB06	0.50				
		D012-M06-Z2	●	12	2	6.5	-	18	B	×	NT-ST009	NT-FTB06	0.50				
		D012-M06-Z3	●	12	3	6.5	-	18	B	×	NT-ST009	NT-FTB06	0.50				
		D012-S12-Z3-L100	●	12	3	12	100	22	A	×	NT-ST009	NT-FTB06	0.50				
		D013-M06-Z2	●	13	2	6.5	-	18	B	×	NT-ST009	NT-FTB06	0.50				
		D013-M06-Z3	●	13	3	6.5	-	18	B	×	NT-ST009	NT-FTB06	0.50				
		D013-S12-Z3-L100	●	13	3	12	100	18	A	×	NT-ST009	NT-FTB06	0.50				
		D016-M08-Z4	●	16	4	8.5	-	23	B	×	NT-ST009	NT-FTB06	0.50				
		D016-S16-Z4-L150	●	16	4	16	150	30	A	×	NT-ST009	NT-FTB06	0.50				
		D017-M08-Z4	●	17	4	8.5	-	23	B	×	NT-ST009	NT-FTB06	0.50				
		D017-S16-Z4-L150	●	17	4	16	150	20	A	×	NT-ST009	NT-FTB06	0.50				
		RDEW0702	NT-RD07	D016-M08-Z2	●	16	2	8.5	-	23	B	×	NT-ST011	NT-FTB09	1.20		
D016-M08-Z3	●			16	3	8.5	-	23	B	×	NT-ST011	NT-FTB09	1.20				
D016-S16-Z2-L150	●			16	2	16	150	25	A	×	NT-ST011	NT-FTB09	1.20				
D017-M08-Z2	●			17	2	8.5	-	23	B	×	NT-ST011	NT-FTB09	1.20				
D017-M08-Z3	●			17	3	8.5	-	23	B	×	NT-ST011	NT-FTB09	1.20				
D017-S16-Z2-L150	●			17	2	16	150	20	A	×	NT-ST011	NT-FTB09	1.20				
D020-M10-Z3	●			20	3	10.5	-	30	B	×	NT-ST011	NT-FTB09	1.20				
D020-S20-Z3-L150	●			20	3	20	150	35	A	×	NT-ST011	NT-FTB09	1.20				
D021-M10-Z2	●			21	2	10.5	-	30	B	×	NT-ST011	NT-FTB09	1.20				
D021-M10-Z3	●			21	3	10.5	-	30	B	×	NT-ST011	NT-FTB09	1.20				
D021-S20-Z3-L150	●			21	3	20	150	25	A	×	NT-ST011	NT-FTB09	1.20				
D025-M12-Z4	●			25	4	12.5	-	35	B	×	NT-ST011	NT-FTB09	1.20				
D025-M12-Z5	●			25	5	12.5	-	35	B	×	NT-ST011	NT-FTB09	1.20				
D025-S25-Z5-L150	●			25	5	25	150	40	A	×	NT-ST011	NT-FTB09	1.20				
D026-M12-Z4	●			26	4	12.5	-	35	B	×	NT-ST011	NT-FTB09	1.20				
D026-M12-Z5	●			26	5	12.5	-	35	B	×	NT-ST011	NT-FTB09	1.20				
D026-S25-Z5-L150	●			26	5	25	150	25	A	×	NT-ST011	NT-FTB09	1.20				
D035-M16-Z5	●			35	5	16.5	-	43	B	×	NT-ST011	NT-FTB09	1.20				
D035-M16-Z6	●			35	6	16.5	-	43	B	×	NT-ST011	NT-FTB09	1.20				
D035-S32-Z6-L150	●			35	6	32	150	30	A	×	NT-ST011	NT-FTB09	1.20				

● stock standard

HOLDERS RD□□10

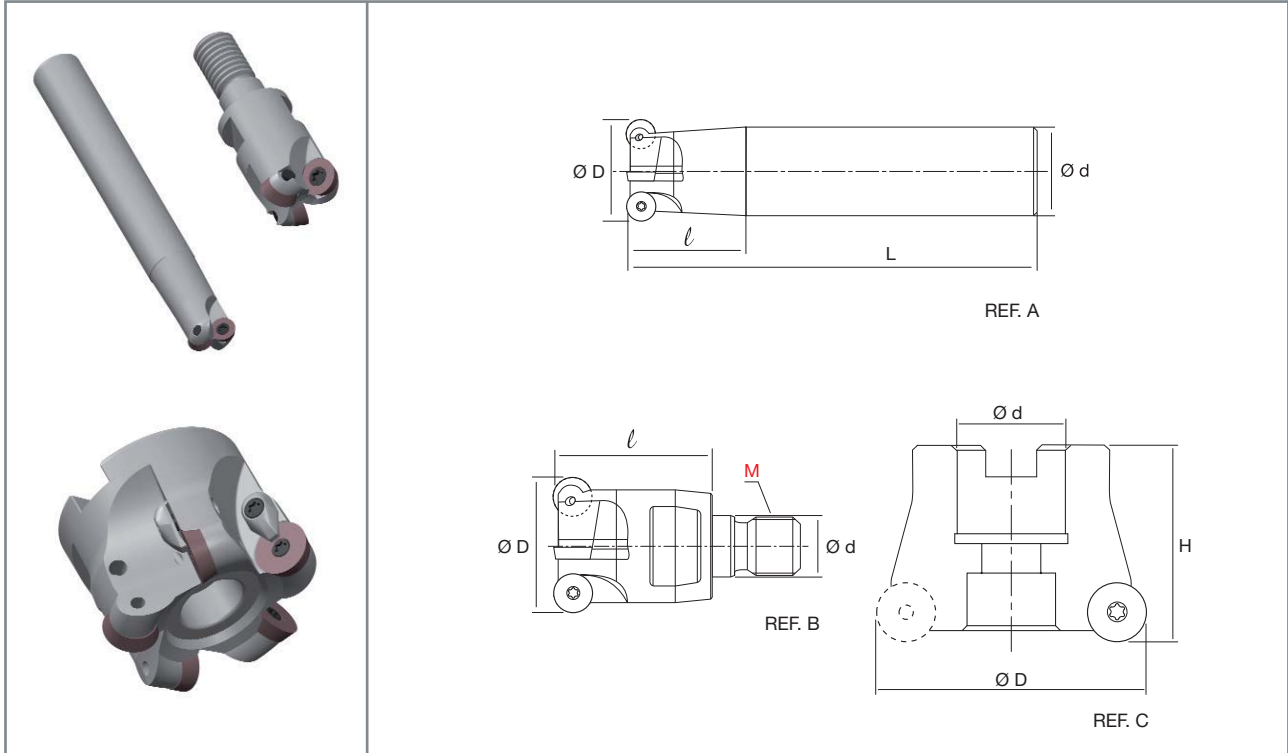

RD□□	DESCRIPTION	STOCK	DIMENSIONS					REF	🔩	← TORQUE Nm				← TORQUE Nm			
			ØD	Z	Ød	L	l			🔩	🔩	🔩	🔩	🔩	🔩		
RDET1003 RDEW1003	NT-RD10	D020-M10-Z2	●	20	2	10.5	-	30	B	×	-	-	-	-	NT-ST012	NT-FTB15	3.50
		D020-S20-Z2-L150	●	20	2	20	150	40	A	×	-	-	-	-	NT-ST012	NT-FTB15	3.50
		D021-M10-Z2	●	21	2	10.5	-	30	B	×	-	-	-	-	NT-ST012	NT-FTB15	3.50
		D021-S20-Z2-L150	●	21	2	20	150	25	A	×	-	-	-	-	NT-ST012	NT-FTB15	3.50
		D025-M12-Z3	●	25	3	12.5	-	35	B	×	-	-	-	-	NT-ST012	NT-FTB15	3.50
		D025-S25-Z3-L150	●	25	3	25	150	40	A	×	-	-	-	-	NT-ST012	NT-FTB15	3.50
		D026-M12-Z3	●	26	3	12.5	-	35	B	×	-	-	-	-	NT-ST012	NT-FTB15	3.50
		D026-S25-Z3-L150	●	26	3	25	150	25	A	×	-	-	-	-	NT-ST012	NT-FTB15	3.50
		D030-M12-Z3	●	30	3	12.5	-	35	B	×	-	-	-	-	NT-ST013	NT-FTB15	3.50
		D030-S25-Z3-L150	●	30	3	25	150	25	A	×	-	-	-	-	NT-ST013	NT-FTB15	3.50
		D032-M16-Z3	●	32	3	16.5	-	43	B	×	NT-CS013	NT-ST013	NT-FTB15	3.50	NT-ST013	NT-FTB15	3.50
		D032-S32-Z3-L150	●	32	3	32	150	40	A	×	NT-CS013	NT-ST013	NT-FTB15	3.50	NT-ST013	NT-FTB15	3.50
		D035-M16-Z3	●	35	3	16.5	-	43	B	×	NT-CS013	NT-ST013	NT-FTB15	3.50	NT-ST013	NT-FTB15	3.50
		D035-M16-Z4	●	35	4	16.5	-	43	B	×	NT-CS013	NT-ST013	NT-FTB15	3.50	NT-ST013	NT-FTB15	3.50
		D035-S32-Z4-L150	●	35	4	32	150	35	A	×	NT-CS013	NT-ST013	NT-FTB15	3.50	NT-ST013	NT-FTB15	3.50
		D042-F16-Z5	●	42	5	16	-	40	C	×	NT-CS013	NT-ST013	NT-FTB15	3.50	NT-ST013	NT-FTB15	3.50
		D052-F22-Z6	●	52	6	22	-	40	C	×	NT-CS013	NT-ST013	NT-FTB15	3.50	NT-ST013	NT-FTB15	3.50
		NT-RD10H	D020-M10-Z2	●	20	2	10.5	-	30	B	✓	-	-	-	-	NT-ST012	NT-FTB15
D025-M12-Z3	●		25	3	12.5	-	35	B	✓	-	-	-	-	NT-ST012	NT-FTB15	3.50	
D035-M16-Z4	●		35	4	16.5	-	43	B	✓	NT-CS013	NT-ST013	NT-FTB15	3.50	NT-ST013	NT-FTB15	3.50	
D042-F16-Z5	●		42	5	16	-	40	C	✓	NT-CS013	NT-ST013	NT-FTB15	3.50	NT-ST013	NT-FTB15	3.50	
D052-F22-Z6	●		52	6	22	-	40	C	✓	NT-CS013	NT-ST013	NT-FTB15	3.50	NT-ST013	NT-FTB15	3.50	

● stock standard

ROUNDPLUS SERIES

HOLDERS RD□□12 - RD□□16

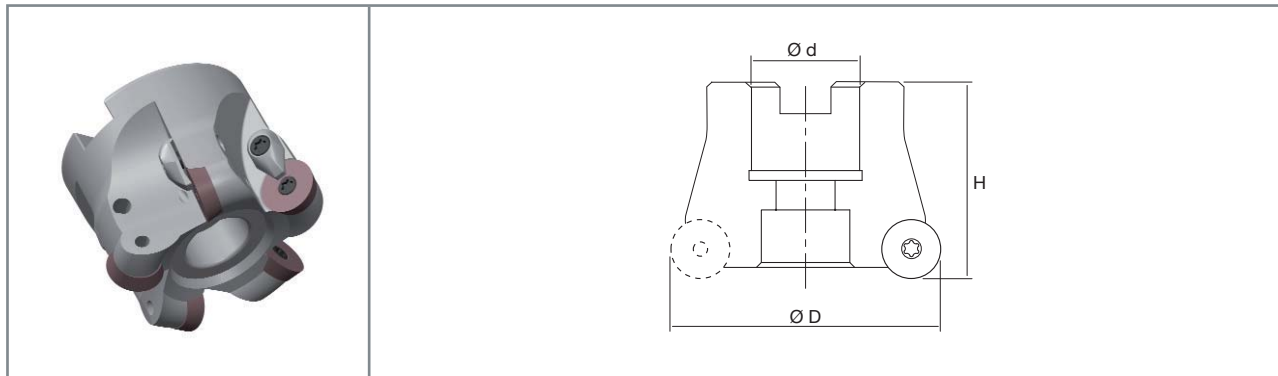

RD□□	DESCRIPTION	STOCK	DIMENSIONS				✕	← TORQUE Nm			← TORQUE Nm			
			ØD	Z	Ød	H		NT-CS013	NT-ST013	NT-FTB15	NT-ST017	NT-FTB15	NT-FTB15	
RDET1204	NT-RD12 D050-F22-Z4	●	50	4	22	50	✕	NT-CS013	NT-ST013	NT-FTB15	3.50	NT-ST017	NT-FTB15	3.50
RDEW1204	D050-F22-Z5	●	50	5	22	50	✕	NT-CS013	NT-ST013	NT-FTB15	3.50	NT-ST019	NT-FTB15	3.50
RDMT1204	D063-F22-Z5	●	63	5	22	50	✕	NT-CS013	NT-ST013	NT-FTB15	3.50	NT-ST017	NT-FTB15	3.50
RDMW1204	D063-F22-Z6	●	63	6	22	50	✕	NT-CS013	NT-ST013	NT-FTB15	3.50	NT-ST017	NT-FTB15	3.50
	D066-F22-Z6	●	66	6	22	50	✕	NT-CS013	NT-ST013	NT-FTB15	3.50	NT-ST017	NT-FTB15	3.50
	D080-F27-Z6	●	80	6	27	50	✕	NT-CS013	NT-ST013	NT-FTB15	3.50	NT-ST017	NT-FTB15	3.50
	NT-RD12H D042-F16-Z4	●	42	4	16	50	✓	NT-CS014	NT-ST013	NT-FTB15	3.50	NT-ST017	NT-FTB15	3.50
	D050-F22-Z5	●	50	5	22	50	✓	NT-CS014	NT-ST013	NT-FTB15	3.50	NT-ST019	NT-FTB15	3.50
	D052-F22-Z5	●	52	5	22	50	✓	NT-CS014	NT-ST013	NT-FTB15	3.50	NT-ST017	NT-FTB15	3.50
	D063-F22-Z6	●	63	6	22	50	✓	NT-CS014	NT-ST013	NT-FTB15	3.50	NT-ST017	NT-FTB15	3.50
	D066-F22-Z6	●	66	6	22	50	✓	NT-CS014	NT-ST013	NT-FTB15	3.50	NT-ST017	NT-FTB15	3.50
	D080-F27-Z7	●	80	7	27	50	✓	NT-CS014	NT-ST013	NT-FTB15	3.50	NT-ST017	NT-FTB15	3.50
RDET1604	NT-RD16 D063-F22-Z5	●	63	5	22	50	✕	NT-CS021	NT-ST021	NT-FTB20	4.50	NT-ST023	NT-FTB20	4.50
RDEW1604	D066-F22-Z5	●	66	5	22	50	✕	NT-CS021	NT-ST021	NT-FTB20	4.50	NT-ST023	NT-FTB20	4.50
RDMW1604	D080-F27-Z5	●	80	5	27	50	✕	NT-CS021	NT-ST021	NT-FTB20	4.50	NT-ST023	NT-FTB20	4.50
	D100-F32-Z6	●	100	6	32	50	✕	NT-CS021	NT-ST021	NT-FTB20	4.50	NT-ST023	NT-FTB20	4.50
	NT-RD16H D063-F22-Z5	●	63	5	22	50	✓	NT-CS021	NT-ST021	NT-FTB20	4.50	NT-ST023	NT-FTB20	4.50
	D066-F27-Z5	●	66	5	27	50	✓	NT-CS021	NT-ST021	NT-FTB20	4.50	NT-ST023	NT-FTB20	4.50
	D080-F27-Z6	●	80	6	27	50	✓	NT-CS021	NT-ST021	NT-FTB20	4.50	NT-ST023	NT-FTB20	4.50
	D100-F32-Z7	●	100	7	32	50	✓	NT-CS021	NT-ST021	NT-FTB20	4.50	NT-ST023	NT-FTB20	4.50
	D125-F40-Z8	●	125	8	40	63	✓	NT-CS021	NT-ST021	NT-FTB20	4.50	NT-ST023	NT-FTB20	4.50

● stock standard

CLAMPING SYSTEM

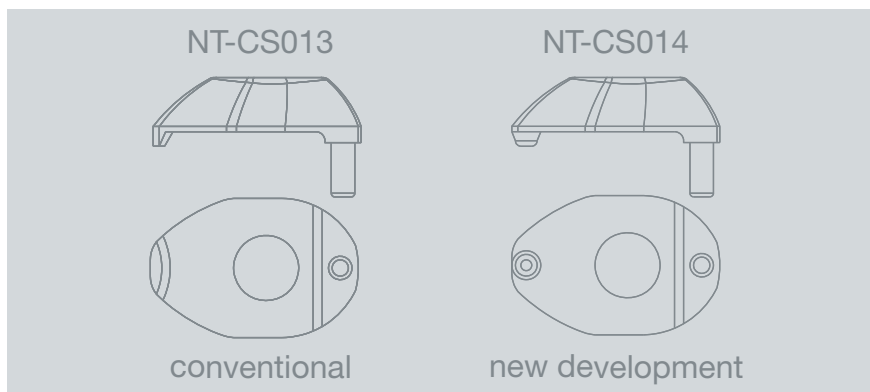

- The new clamping system (NT-CS014), a standard feature on NT-RD12H series and available separately for NT-RD series, has been designed to facilitate the inserts repositioning in combination with the dotted types D6 and D8.
- The rounded front part perfectly fits in the dots on the insert top face.
- The same clamp fits on flat type inserts and positive inserts with chip breakers GP and SC.



- Il nuovo sistema di bloccaggio (NT-CS014), adottato come standard per la serie NT-RD12H e disponibile separatamente per la serie NT-RD12, è stato progettato per aiutare il riposizionamento degli inserti in combinazione con le tipologie D6 e D8.
- La parte anteriore arrotondata della staffa si adatta perfettamente agli incavi presenti sugli inserti.
- La stessa staffa può fissare anche gli inserti piatti o con rompitruccioli GP ed SC.



- Das neue Spannsystem (NT-CS014), eine Standardfunktion der NT-Serie RD12H und separat erhältlich für die NT-RD-Serie wurde entwickelt, um die Neupositionierung in Verbindung mit den Art. D6 und D8 zu erleichtern.
- Die abgerundete Vorderseite der Halterung passt perfekt zu den an den Einsätzen vorliegenden Nuten.
- Die gleiche Halterung kann die Wendeschneidplatten mit Spanbrecher GP und SC befestigen.



- Le nouveau système de serrage (NT-CS014), standard pour la série NT-RD12H, fourni séparément pour la série NT-RD12, a été conçu pour aider le repositionnement des inserts de types D6 et D8.
- La partie intérieure arrondie de la bride s'adapte parfaitement aux encoches des plaquettes.
- La même bride peut fixer aussi les plaquettes plates avec les brise-copeaux GP et SC.



- El nuevo sistema de sistema de bloqueo (NT-CS014) adoptado como estándar para la serie NT-RD12H y disponible por separado para la serie NT-RD12, está diseñado para ayudar al reposicionamiento de las placas en combinación con los tipos D6 y D8.
- El frente redondeado del soporte se adapta perfectamente con las ranuras presente en las placas.
- La misma brida puede fijar también las placas planas y las con rompevirutas GP y SC.



- Новая система крепежа (NT-CS014), принятая как стандарт для серии NT-RD12H, которая предлагается отдельно для серии NT-RD12, была разработана для упрощения установки пластин с углублениями типа D6 и D8.
- Закруглённая фронтальная часть крепежа совпадает с углублениями на пластине
- Крепление подходит как для плоских, так и для позитивных пластин со стружколомом GP и SC.

ROUNDPLUS SERIES

INSERTS RD

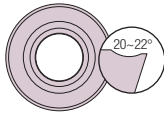
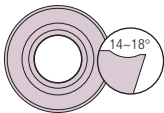
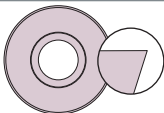
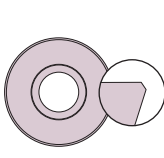
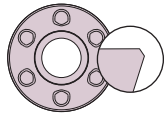
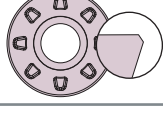
DESCRIPTION	IC				HC					HT									
	IC	T	r	Ød	JP5520	JP5530	JP9535	JC7515	JP7525	JU4525									
 SC	RDET 1003M0-SC	10	3.18	5.0	3.80	●	●												
	10T3M0-SC	10	3.97	5.0	4.40	○	●												
	1204M0-SC	12	4.76	6.0	4.40	●	●												
	1604M0-SC	16	4.76	8.0	5.00	●	●												
 GP	RDET 1003M0-GP	10	3.18	5.0	3.80	●	●	★											
	10T3M0-GP	10	3.97	5.0	4.40	●	●												
	1204M0-GP	12	4.76	6.0	4.40	●	●	★											
	1604M0-GP	16	4.76	8.0	5.00	●	●	★											
	RDMT 1204M0-GP	12	4.76	6.0	4.40	●	●												
 TES	RDEW 0501M0-TES	5	1.51	2.5	2.20	●	●			●									
	0702M0-TES	7	2.38	3.5	2.80	●					●								
 TE	RDEW 0702M0-TE	7	2.38	3.5	2.80	●	●				●								
	0803M0-TE	8	3.18	4.0	2.94	○													
	1003M0-TE	10	3.18	5.0	3.80	●	●				●								
	10T3M0-TE	10	3.97	5.0	4.40	●	●												
	1204M0-TE	12	4.76	6.0	4.40	●	●		★	●									
	1604M0-TE	16	4.76	8.0	5.00	●	●		★	●									
	RDMW 1604M0-TE	16	4.76	8.0	5.00	●	●												
 TE (06)	RDEW 1204M0-TE-D6	12	4.76	6.0	4.40	●	●												
	1605M0-TE-D6	16	5.56	8.0	5.50	■													
	RDMW 1204M0-TE-D6	12	4.76	6.0	4.40	●													
 TE (08)	RDEW 12T3M0-TE-D8	12	3.97	6.0	4.40	●	●												
	1204M0-TE-D8	12	4.76	6.0	4.40	●	●												
	RDMW 1204M0-TE-D8	12	4.76	6.0	4.40	●	●												
	1605M0-TE-D8	16	5.56	8.0	5.50	○	●												

● stock standard; ○ non-stock standard; ■ stock exhaustion; ★ upcoming introduction

HC: coated carbide
HT: cermet

JP: PVD coating
JC: CVD coating
JU: uncoated

HOLDERS RP□□12

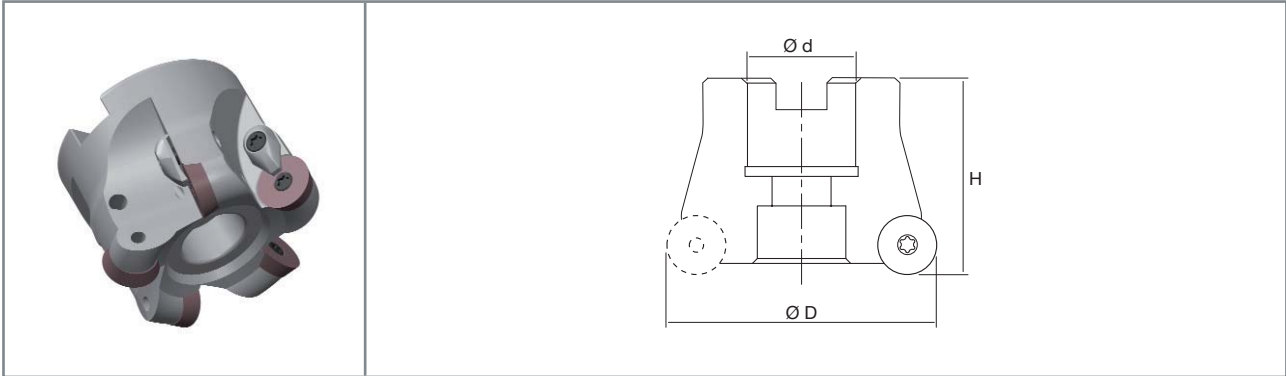

RP□□	DESCRIPTION	STOCK	DIMENSIONS				✓	← TORQUE Nm			← TORQUE Nm			
			ØD	Z	Ød	H		←	←	←	←	←	←	
RPET1204	NT-RP12H D042-F16-Z4	●	42	4	16	50	✓	NT-CS013	NT-ST013	NT-FTB15	3.50	NT-ST017	NT-FTB15	3.50
RPEW1204	D050-F22-Z5	●	50	5	22	50	✓	NT-CS013	NT-ST013	NT-FTB15	3.50	NT-ST017	NT-FTB15	3.50
RPMT1204	D052-F22-Z5	●	52	5	22	50	✓	NT-CS013	NT-ST013	NT-FTB15	3.50	NT-ST017	NT-FTB15	3.50
RPMW1204	D063-F22-Z6	●	63	6	22	50	✓	NT-CS013	NT-ST013	NT-FTB15	3.50	NT-ST017	NT-FTB15	3.50
	D066-F22-Z6	●	66	6	22	50	✓	NT-CS013	NT-ST013	NT-FTB15	3.50	NT-ST017	NT-FTB15	3.50
	D080-F27-Z7	●	80	7	27	50	✓	NT-CS013	NT-ST013	NT-FTB15	3.50	NT-ST017	NT-FTB15	3.50

● stock standard

INSERTS RP□□12

DESCRIPTION	IC		T		r	Ød	HC					HT		
	IC	T	JP5520	JP5530			JP9535	JC7515	JP7525	JU4525				
SC	RPET 1003M0-SC	10	3.18	5.0	4.40	●	●							
	1204M0-SC	12	4.76	6.0	4.40	●	●							
GP	RPET 1204M0-GP	12	4.76	6.0	4.40	●	●							
	RPMT 1204M0-GP	12	4.76	6.0	4.40	●	●	★						
TE	RPEW 1003M0-TE	10	3.18	5.0	4.40	○	○							
	1204M0-TE	12	4.76	6.0	4.40	●	●							
	RPMW1003M0-TE	10	3.18	5.0	4.40	○	○							
	1204M0-TE	12	4.76	6.0	4.40	●	●							

● stock standard; ○ non-stock standard; ★ upcoming introduction

HC: coated carbide
HT: cermet

JP: PVD coating
JC: CVD coating
JU: uncoated

ROUNDPLUS SERIES

GRADES APPLICATION CHART

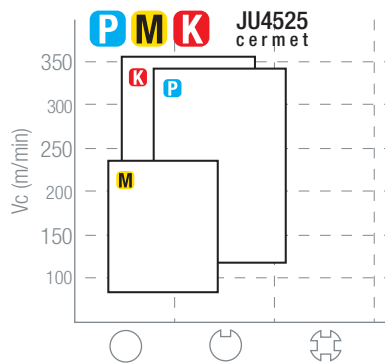
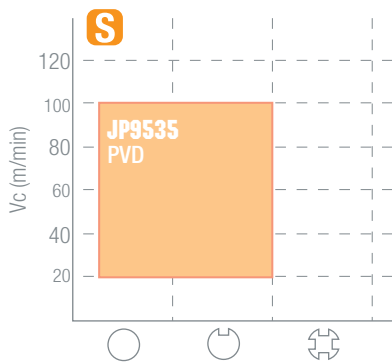
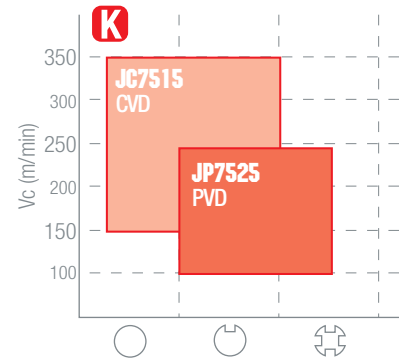
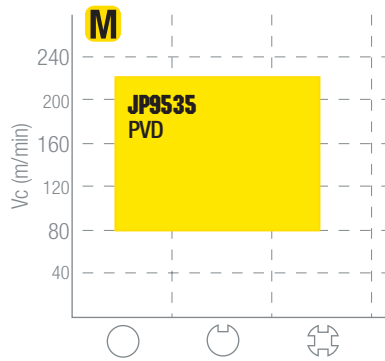
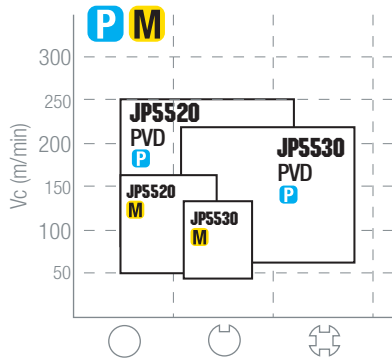

INSERTS APPLICATION CHART

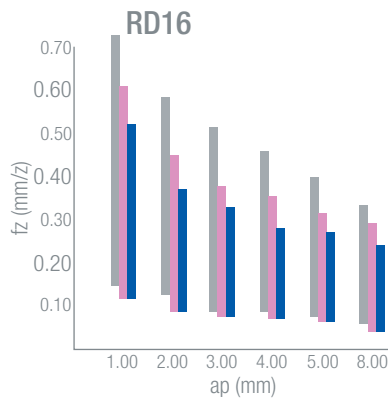
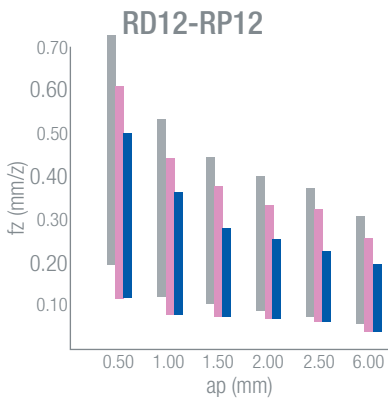
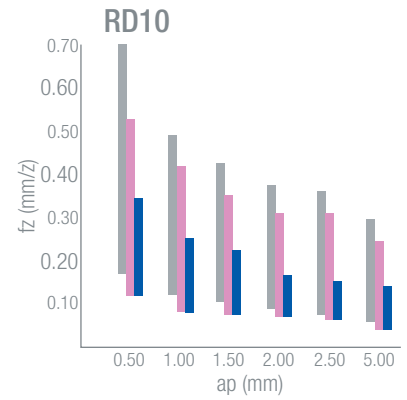
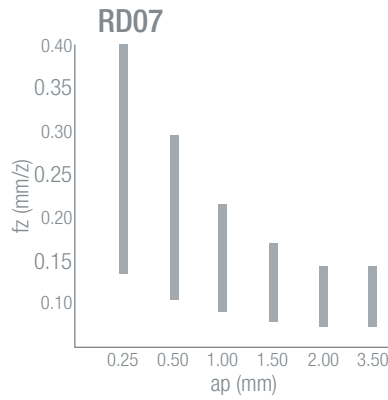
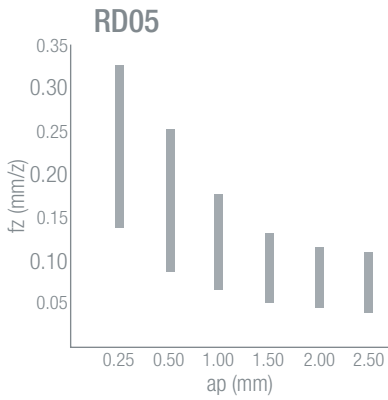

■ SC ■ GP ■ TE/TES



JU4525 cermet → fz-20%
Please reduce the feed rate by 20%

ROUNDPLUS SERIES

CUTTING SPEED (Vc m/min)

Gr.	MATERIAL		
P1	Free cutting steel and structural steel	Rm < 500 N/mm ²	(9SMn28 / 1.0715 / AVP)
P2	Carbon steel and low alloy steel	Rm 500-700 N/mm ²	(C40 / 1.0511)
P3	Medium alloy steel and heat treated steel	Rm 600-800 N/mm ²	(42CrMo4 / 1.7225)
P4	High alloy steel	Rm 800-1000 N/mm ²	(100Cr6 / 1.3505)
P5	Tool steel	Rm 900-1200 N/mm ²	(X210Cr12 / 1.2080 / K100)
P6	High tensile strength steel	Rm 1200-1600 N/mm ²	(X2NiCrMo18.9.5 / 1.6358 / W720)
M1	Ferritic stainless steel	Rm 400-700 N/mm ²	(X40Cr13 / 1.4034 / AISI420)
M2	Austenitic stainless steel (good machinability)	Rm 500-750 N/mm ²	(X5CrNi18.10 / 1.4301 / AISI304)
M3	Austenitic stainless steel (medium machinability)	Rm 550-850 N/mm ²	(X2CrNiMo18.12 / 1.4435 / AISI316L)
M4	Martensitic stainless steel	Rm 650-950 N/mm ²	(X2CrNiMoN25.7.4 / 1.4410 / Super Duplex)
M5	PH stainless steel	Rm 800-1250 N/mm ²	(X5CrNiNb16.4 / 1.4542 / 17-4PH)
K1	Grey cast iron	HB 150-250	(GG-25 / 0.6025)
K2	Nodular cast iron	HB 150-350	(GGG-50 / 0.7050)
K3	Austenitic cast iron	HB 120-260	(GGL-NiCr20.2 / 0.6660)
K4	ADI cast iron	HB 250-500	(GJS-1000-5 / ADI 1000)
S1	Heat resistant super alloys HRSA (good machinability)	HRC < 25	(NiCr17Mo17FeW / 2.4802 / Hastelloy)
S2	Heat resistant super alloys HRSA (medium machinability)	HRC 25-35	(NiCr20Ti / 2.4630 / Nimonic 80)
S3	Heat resistant super alloys HRSA (low machinability)	HRC 35-45	(NiCr19Fe19NbMo / 2.4668 / Inconel 718)
S4	Low alloy titanium		(Ti99.6 / 3.7055 / Titanium grade 3)
S5	High alloy titanium		(Ti5Al2.5Sn / 3.7115 / Titanium grade 6)

Gr.	JP5520	JP5530	JP9535	JC7515	JP7525	JU4525
P1	200 ÷ 250	180 ÷ 230				250 ÷ 350
P2	160 ÷ 220	150 ÷ 210				220 ÷ 300
P3	140 ÷ 200	120 ÷ 180				200 ÷ 280
P4	120 ÷ 160	100 ÷ 150				160 ÷ 220
P5	100 ÷ 140	80 ÷ 130				
P6	80 ÷ 120	60 ÷ 110				
M1	100 ÷ 160	90 ÷ 150	120 ÷ 220			140 ÷ 240
M2	80 ÷ 140	80 ÷ 130	100 ÷ 200			120 ÷ 200
M3	60 ÷ 120	60 ÷ 100	120 ÷ 180			100 ÷ 180
M4			90 ÷ 150			
M5			80 ÷ 140			
K1				200 ÷ 350	150 ÷ 240	250 ÷ 380
K2				180 ÷ 280	120 ÷ 200	200 ÷ 300
K3				140 ÷ 200	100 ÷ 150	160 ÷ 220
K4				120 ÷ 180		
S1			30 ÷ 60			
S2			30 ÷ 50			
S3			20 ÷ 40			
S4			50 ÷ 100			
S5			40 ÷ 80			



OKTOPLUS SERIES

High performance on face milling.

ISO

P

M

K

N

S



8 edges

nixkoTOOLS

OKTOPLUS SERIES

HOLDERS OFKT05

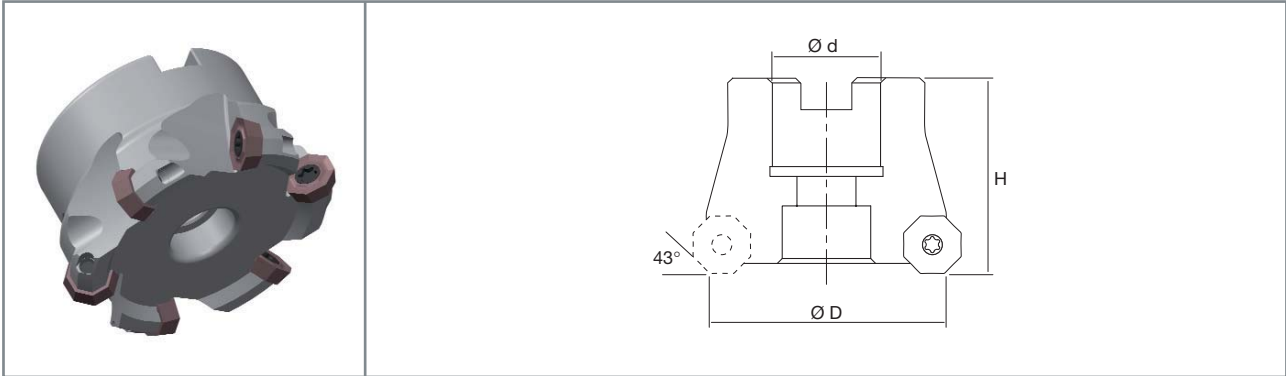



OFKT	DESCRIPTION	STOCK	DIMENSIONS				✓	NT-ST024	NT-FTB15	TORQUE Nm				
			ØD	Z	Ød	H								
OFKT05T3	NT-OF05H D050-F22-Z5	●	50	5	22	40	✓	NT-ST024	NT-FTB15	3.50				
	D063-F22-Z6	★	63	6	22	40	✓	NT-ST024	NT-FTB15	3.50				
	D080-F27-Z7	★	80	7	27	50	✓	NT-ST024	NT-FTB15	3.50				
	D100-F32-Z8	★	100	8	32	50	✓	NT-ST024	NT-FTB15	3.50				

● stock standard; ★ upcoming introduction



We will continue to supply the equivalent milling cutters without coolant holes (description: NT-OF05) until availability of items marked with ★.

INSERTS

DESCRIPTION	DIMENSIONS						COATINGS							HW
	IC	T	r	b	Ød	JP5520	JP5530	JP8525	JC8530	JP9525	JC7515	JP7525	JC7530	
GP  OFKT 05T305-GP	12.70	3.97	0.5	1.10	4.40			●	●	●			●	
AL  POLISHED OFKT 05T305-AL	12.70	3.97	0.5	1.10	4.40									●

● stock standard

HC: coated carbide
HW: uncoated carbide

JP: PVD coating
JC: CVD coating
JU: uncoated

HOLDERS ODKT06

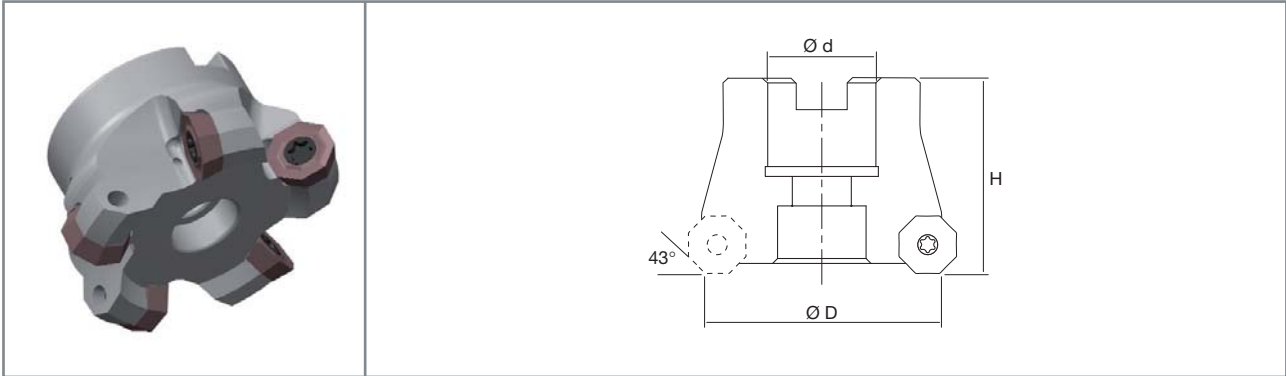

OD□□	DESCRIPTION	STOCK	DIMENSIONS				✓	🔩	🔧	TORQUE Nm				
			ØD	Z	Ød	H								
ODKT0605	NT-OD06H D050-F22-Z4	●	50	4	22	40	✓	NT-ST021	NT-FTB20	4.50				
ODKW0605	D063-F22-Z5	●	63	5	22	40	✓	NT-ST021	NT-FTB20	4.50				
ODMT0605	D080-F27-Z6	●	80	6	27	50	✓	NT-ST021	NT-FTB20	4.50				
	D100-F32-Z7	●	100	7	32	50	✓	NT-ST021	NT-FTB20	4.50				
	D125-F40-Z8	●	125	8	40	63	✓	NT-ST021	NT-FTB20	4.50				
	D160-F40-Z10	●	160	10	40	63	✓	NT-ST021	NT-FTB20	4.50				

● stock standard

INSERTS

DESCRIPTION								HC							HW	
		IC	T	r	b	Ød	JP5520	JP5530	JP8525	JC8530	JP9525	JP9535	JC7515	JP7525	JC7530	JU6520
SC	ODKT 060508-SC	15.875	5.56	0.8	1.80	5.5	●	●				★				
GP	ODKT 060508-GP	15.875	5.56	0.8	1.80	5.5	●	●				★	★	●		
	ODMT 060508-GP	15.875	5.56	0.8	1.80	5.5	★									
TE	ODKT 060508-TE	15.875	5.56	0.8	1.80	5.5	●	●								
	ODMT 060508-TE	15.875	5.56	0.8	1.80	5.5	★									
AL	POLISHED ODKT 060508-AL	15.875	5.56	0.8	1.80	5.5										●
WU WIPER	ODKW 060508-WU	15.875	5.56	0.8	6.40	5.5	●	●								

● stock standard; ★ upcoming introduction

HC: coated carbide
HW: uncoated carbide

JP: PVD coating
JC: CVD coating
JU: uncoated

OKTOPLUS SERIES

GRADES APPLICATION CHART

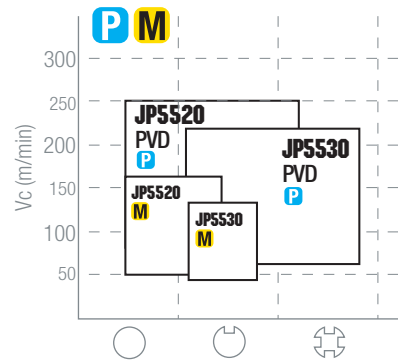
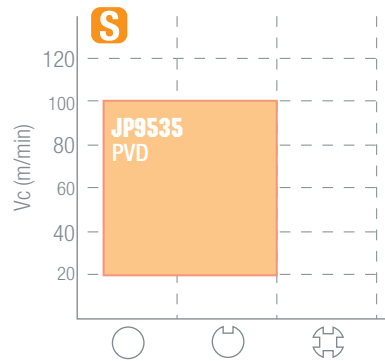
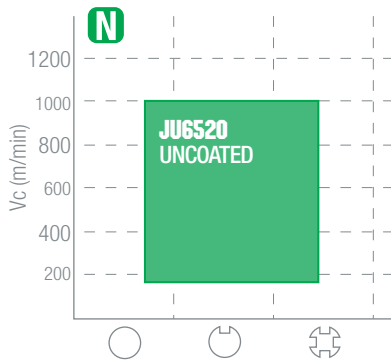
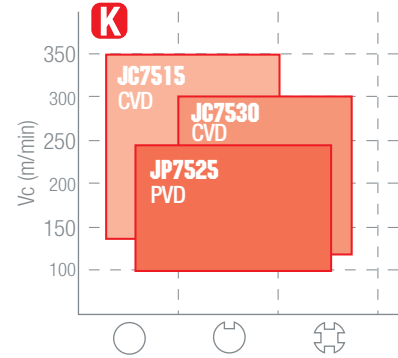
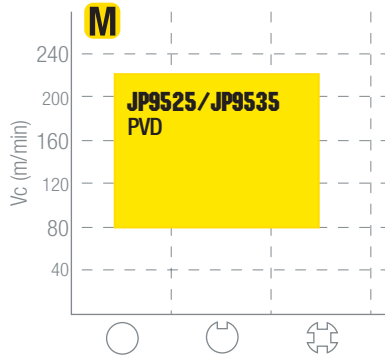
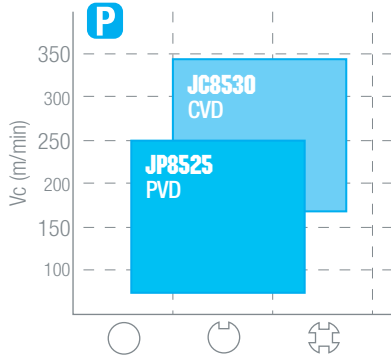

CHIPBREAKERS APPLICATION CHART

OFKT05

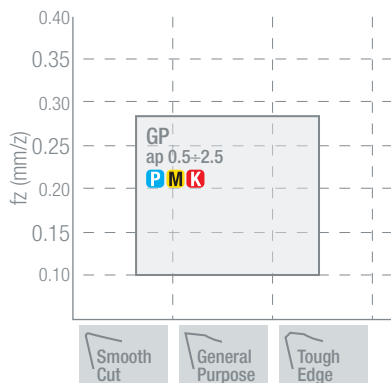

ODKT06

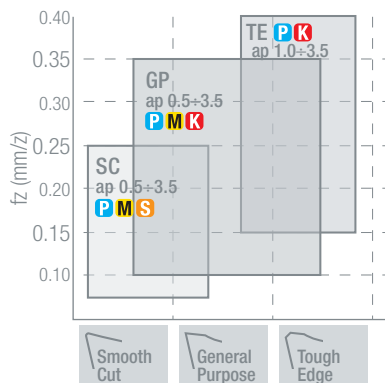

OFKT05 / ODKT06

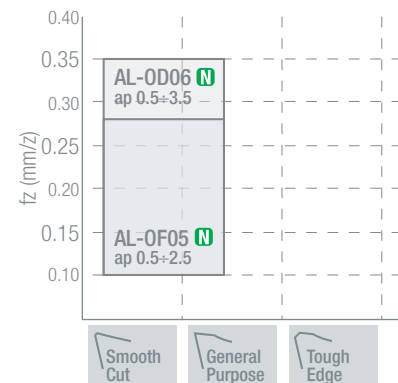

WIPER APPLICATION CHART

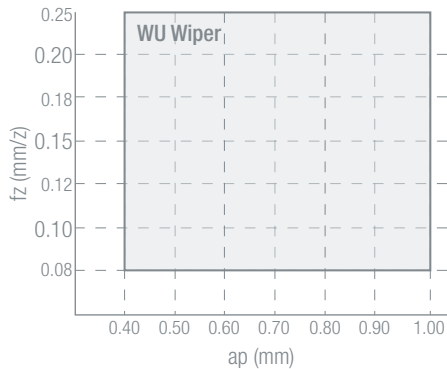

WIPER INSTALLATION (ODKW060508-WU)

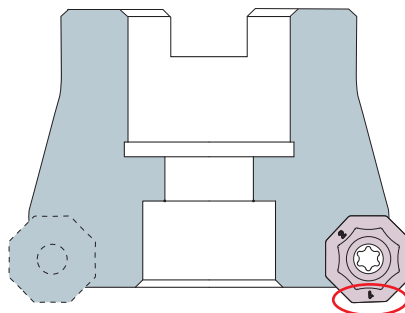

- Please follow the clamping procedure shown in the picture.
- The cutting edges of WU style inserts are marked with digits 1 and 2.
- Only 1 wiper insert per setup.



- Installare l'inserto come mostrato in figura.
- La geometria WU ha due taglienti marcati con il numero 1 e 2.
- Installare un solo inserto wiper sul corpo fresa.



- Installieren Sie die Wendeschneidplatte wie in der Abbildung gezeigt.
- Die Geometrie WU hat zwei Schneiden mit der Nummer 1 und 2 markiert.
- Befestigen Sie nur eine Wendeschneidplatte WIPER auf den Schneidkörper



- Installer la plaquette comme le montre la photo.
- La géométrie WU a deux arêtes de coupe, marquées avec le numéro 1 et 2.
- Installer une seule plaquette wiper sur le corps d'outil.



- Instalar la placa como ilustrado en la figura.
- La geometría WU tiene dos filos marcados con el número 1 y 2.
- Instalar una sola placa wiper en el cuerpo de la fresa.



- Устанавливайте пластину как указано на рисунке.
- Геометрия WU обладает двумя режущими кромками обозначенные цифрами 1 и 2.
- Только одну пластину wiper устанавливайте на фрезу.

OKTOPLUS SERIES

CUTTING SPEED (Vc m/min)

Gr.	MATERIAL		
P1	Free cutting steel and structural steel	Rm < 500 N/mm ²	(9SMn28 / 1.0715 / AVP)
P2	Carbon steel and low alloy steel	Rm 500-700 N/mm ²	(C40 / 1.0511)
P3	Medium alloy steel and heat treated steel	Rm 600-800 N/mm ²	(42CrMo4 / 1.7225)
P4	High alloy steel	Rm 800-1000 N/mm ²	(100Cr6 / 1.3505)
P5	Tool steel	Rm 900-1200 N/mm ²	(X210Cr12 / 1.2080 / K100)
P6	High tensile strength steel	Rm 1200-1600 N/mm ²	(X2NiCrMo18.9.5 / 1.6358 / W720)
M1	Ferritic stainless steel	Rm 400-700 N/mm ²	(X40Cr13 / 1.4034 / AISI420)
M2	Austenitic stainless steel (good machinability)	Rm 500-750 N/mm ²	(X5CrNi18.10 / 1.4301 / AISI304)
M3	Austenitic stainless steel (medium machinability)	Rm 550-850 N/mm ²	(X2CrNiMo18.12 / 1.4435 / AISI316L)
M4	Martensitic stainless steel	Rm 650-950 N/mm ²	(X2CrNiMoN25.7.4 / 1.4410 / Super Duplex)
M5	PH stainless steel	Rm 800-1250 N/mm ²	(X5CrNiNb16.4 / 1.4542 / 17-4PH)
K1	Grey cast iron	HB 150-250	(GG-25 / 0.6025)
K2	Nodular cast iron	HB 150-350	(GGG-50 / 0.7050)
K3	Austenitic cast iron	HB 120-260	(GGL-NiCr20.2 / 0.6660)
K4	ADI cast iron	HB 250-500	(GJS-1000-5 / ADI 1000)
N1	Aluminium alloys < 12% Si		(AlMgSi0.5 / 3.3206)
N2	Aluminium alloys > 12% Si		(AlSi12 / 3.2582)
N3	Copper alloys		(E-Cu57 / 2.0060)
N4	Brass alloys and bronze alloys		(CuZn20Al2 / 2.0460)
S1	Heat resistant super alloys HRSA (good machinability)	HRC < 25	(NiCr17Mo17FeW / 2.4802 / Hastelloy)
S2	Heat resistant super alloys HRSA (medium machinability)	HRC 25-35	(NiCr20Ti / 2.4630 / Nimonic 80)
S3	Heat resistant super alloys HRSA (low machinability)	HRC 35-45	(NiCr19Fe19NbMo / 2.4668 / Inconel 718)
S4	Low alloy titanium		(Ti99.6 / 3.7055 / Titanium grade 3)
S5	High alloy titanium		(Ti5Al2.5Sn / 3.7115 / Titanium grade 6)

Gr.	JP5520	JP5530	JP8525	JC8530	JP9525	JP9535	JC7515	JP7525	JC7530	JU6520
P1	200 ÷ 250	180 ÷ 230	200 ÷ 250	240 ÷ 320						
P2	160 ÷ 220	150 ÷ 210	160 ÷ 220	200 ÷ 280						
P3	140 ÷ 200	120 ÷ 180	140 ÷ 200	180 ÷ 240						
P4	120 ÷ 160	100 ÷ 150	120 ÷ 160	140 ÷ 200						
P5	100 ÷ 140	80 ÷ 130	100 ÷ 140	120 ÷ 180						
P6	80 ÷ 120	60 ÷ 110	80 ÷ 120	100 ÷ 160						
M1	100 ÷ 160	90 ÷ 150			130 ÷ 220	120 ÷ 220				
M2	80 ÷ 140	80 ÷ 130			110 ÷ 180	100 ÷ 200				
M3	60 ÷ 120	60 ÷ 100			90 ÷ 160	120 ÷ 180				
M4					80 ÷ 140	90 ÷ 150				
M5					70 ÷ 120	80 ÷ 140				
K1							200 ÷ 350	150 ÷ 240	160 ÷ 300	
K2							180 ÷ 280	120 ÷ 200	140 ÷ 240	
K3							140 ÷ 200	100 ÷ 150	120 ÷ 180	
K4							120 ÷ 180		100 ÷ 150	
N1										400 ÷ 1000
N2										300 ÷ 600
N3										300 ÷ 500
N4										200 ÷ 400
S1						30 ÷ 60				
S2						30 ÷ 50				
S3						20 ÷ 40				
S4						50 ÷ 100				
S5						40 ÷ 80				



4FACE PLUS SERIES

The all-around solution for face milling.

ISO

P

M

K

N

S

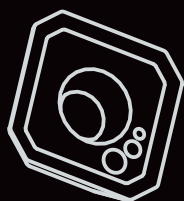

4 edges

nixkoTOOLS

4FACEPLUS SERIES

HOLDERS

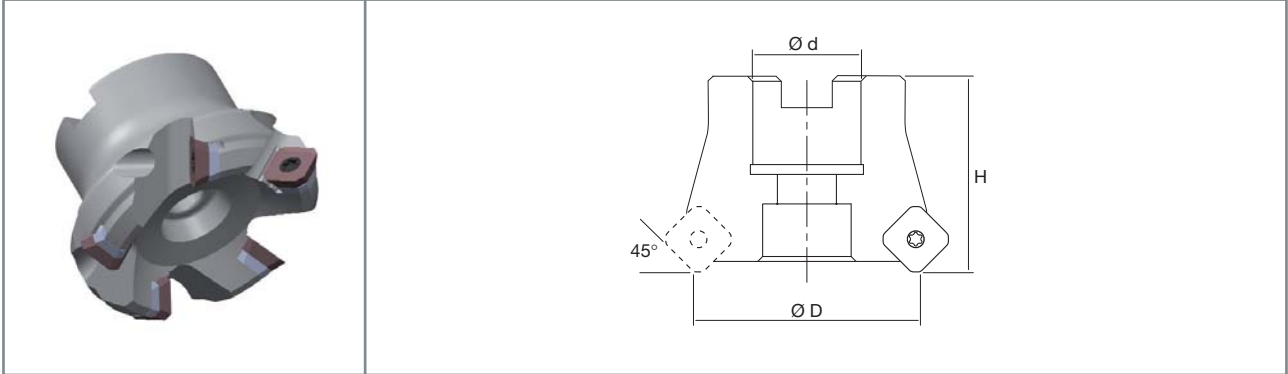

SE□□	DESCRIPTION	STOCK	DIMENSIONS				✕	TORQUE Nm			TORQUE Nm			
			ØD	Z	Ød	H		NT-SH004	NT-SR002	NT-WR035	NT-ST040	NT-FT15	NT-FT15	
SEET13T3	NT-SE13	●	50	4	22	40	✕	NT-SH004	NT-SR002	NT-WR035	5.0	NT-ST040	NT-FT15	3.5
SEEW13T3		●	50	5	22	40	✕	NT-SH004	NT-SR002	NT-WR035	5.0	NT-ST040	NT-FT15	3.5
SEMT13T3		●	63	5	22	50	✕	NT-SH004	NT-SR002	NT-WR035	5.0	NT-ST040	NT-FT15	3.5
		●	63	6	22	50	✕	NT-SH004	NT-SR002	NT-WR035	5.0	NT-ST040	NT-FT15	3.5
		●	80	6	27	50	✕	NT-SH004	NT-SR002	NT-WR035	5.0	NT-ST040	NT-FT15	3.5
		●	80	8	27	50	✕	NT-SH004	NT-SR002	NT-WR035	5.0	NT-ST040	NT-FT15	3.5
		●	100	7	32	50	✕	NT-SH004	NT-SR002	NT-WR035	5.0	NT-ST040	NT-FT15	3.5
		●	100	10	32	50	✕	NT-SH004	NT-SR002	NT-WR035	5.0	NT-ST040	NT-FT15	3.5
		●	125	8	40	63	✕	NT-SH004	NT-SR002	NT-WR035	5.0	NT-ST040	NT-FT15	3.5
		●	125	12	40	63	✕	NT-SH004	NT-SR002	NT-WR035	5.0	NT-ST040	NT-FT15	3.5
		●	160	10	40	63	✕	NT-SH004	NT-SR002	NT-WR035	5.0	NT-ST040	NT-FT15	3.5
		○	160	16	40	63	✕	NT-SH004	NT-SR002	NT-WR035	5.0	NT-ST040	NT-FT15	3.5
		●	200	12	60	63	✕	NT-SH004	NT-SR002	NT-WR035	5.0	NT-ST040	NT-FT15	3.5
		○	200	20	60	63	✕	NT-SH004	NT-SR002	NT-WR035	5.0	NT-ST040	NT-FT15	3.5

● stock standard; ○ non stock standard

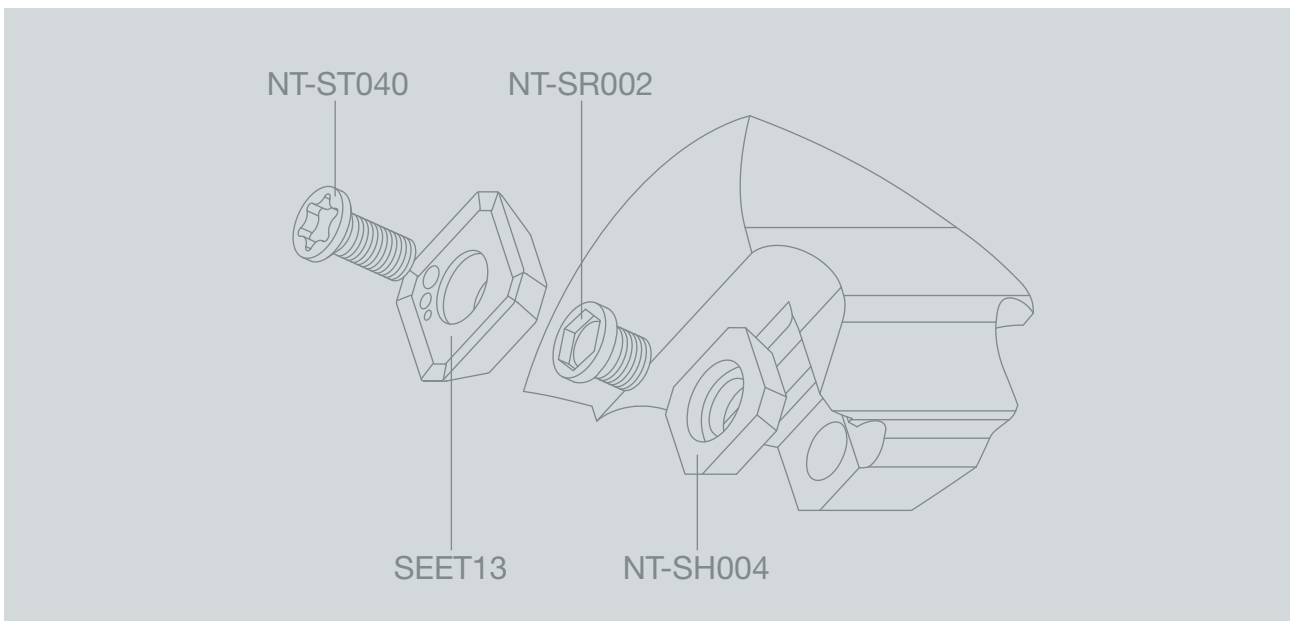

INSERTS

DESCRIPTION						HC						HW	HT			
		IC	T	b	Ød	JP5520	JP5530	JP8525	JC8530	JP9525	JP9535	JC7515	JP7525	JC7530	JU6520	JU4525
SC		SEET 13T3AGEN-SC	13.40	3.97	1.70	4.40	●	●				★				
GP		SEET 13T3AGEN-GP	13.40	3.97	1.20	4.40	●	●	●	●	●	★				●
		SEMT 13T3AGEN-GP	13.40	3.97	1.20	4.40	★									
TE		SEET 13T3AGSN-TE	13.40	3.97	1.20	4.40	●	●								
		SEMT 13T3AGSN-TE	13.40	3.97	1.20	4.40	★									
GG		SEET 13T3AGSN-GG	13.40	3.97	1.30	4.40						●	●			
GH		SEET 13T3AGSN-GH	13.40	3.97	1.30	4.40						●				
(Flat)		SEEW 13T3AGSN	13.40	3.97	2.00	4.40								●		
AL		POLISHED SEET 13T3AGFN-AL	13.40	3.97	2.20	4.40									●	
WU WIPER		SEET 13T3-WU	13.40	3.97	7.50	4.40		●								

● stock standard; ★ upcoming introduction

HC: coated carbide
 HW: uncoated carbide
 HT: Cermet
 JP: PVD coating
 JC: CVD coating
 JU: uncoated

4FACEPLUS SERIES

GRADES APPLICATION CHART

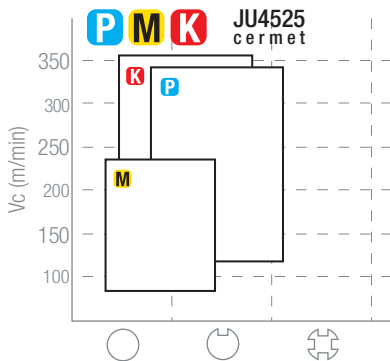
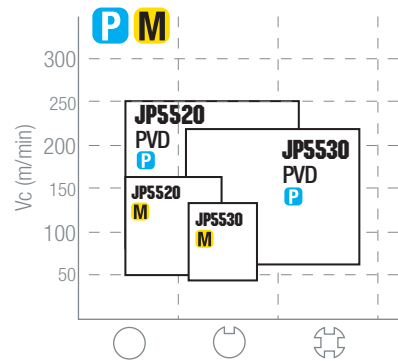
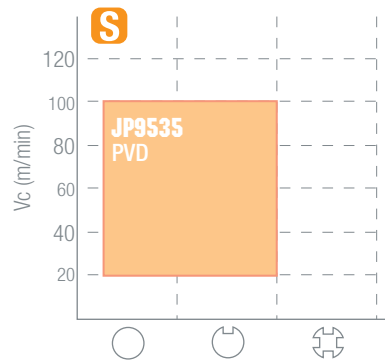
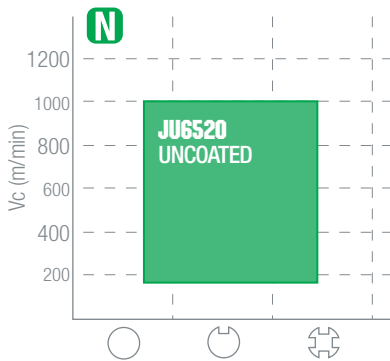
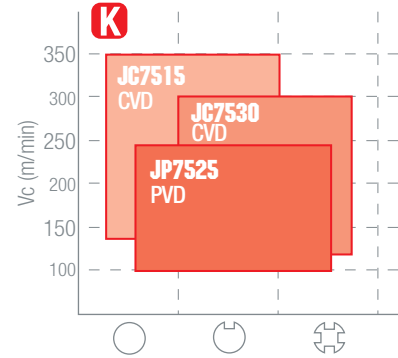
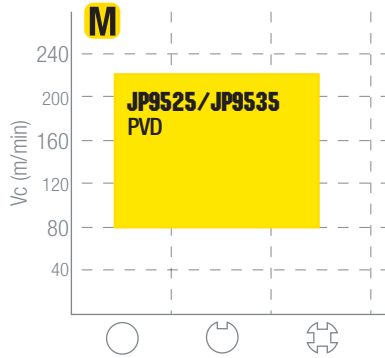
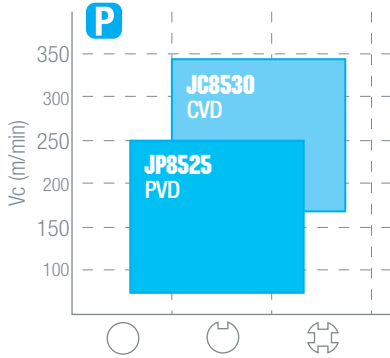

⚠️ JU4525 cermet → fz-20%
Please reduce the feed rate by 20%

CHIPBREAKERS APPLICATION CHART

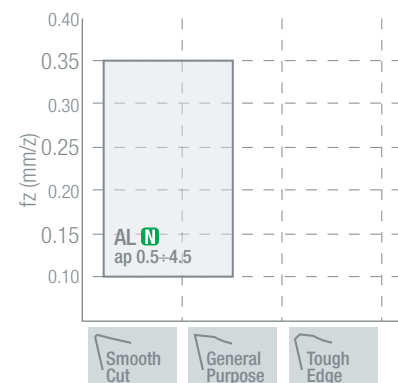
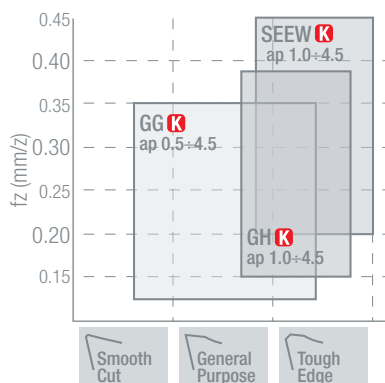
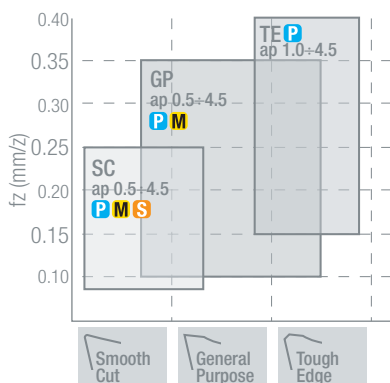

WIPER APPLICATION CHART

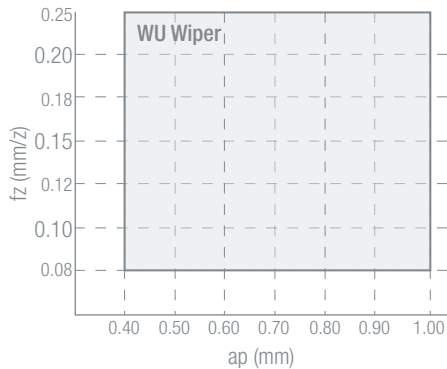

WIPER INSTALLATION

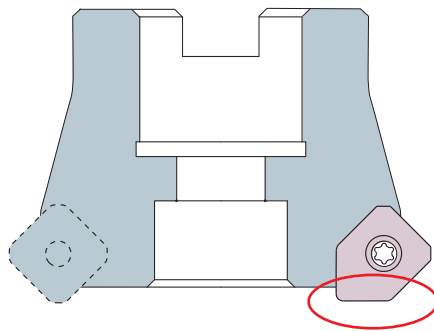

- The wiper insert must be mounted face towards the centre of the holder (see picture).
- WU style inserts feature only 1 cutting edge.
- Only 1 wiper insert per setup.



- Installare l'inserto wiper rivolto verso il centro della fresa (vedere figura).
- La geometria WU ha 1 solo tagliante utilizzabile.
- Installare un solo inserto wiper sul corpo fresa.



- Befestigen Sie die Wendeschneidplatte WIPER gegenüber der Mitte des Werkzeugs (siehe Abbildung).
- Die WU-Geometrie hat nur eine nutzbare Schneide.
- Befestigen Sie nur eine Wendeschneidplatte WIPER auf den Schneidkörper.



- Installer la plaquette wiper en face du centre de la fraise (voir photo).
- La géométrie WU a une seule arête utilisable.
- Installer une seule plaquette wiper sur le corps d'outil.



- Instalar la placa wiper frente al centro de la herramienta (ver Figura).
- La geometría WU tiene un sólo filo útil.
- Instalar una sola placa wiper en el cuerpo fresa.



- Устанавливайте пластину wiper в направлении к центру фрезы (см. рисунок).
- Пластины с геометрией WU обладают только одной режущей кромкой.
- Только одну пластину wiper устанавливайте на фрезу.

4FACEPLUS SERIES

CUTTING SPEED (Vc m/min)

Gr.	MATERIAL		
P1	Free cutting steel and structural steel	Rm < 500 N/mm ²	(9SMn28 / 1.0715 / AVP)
P2	Carbon steel and low alloy steel	Rm 500-700 N/mm ²	(C40 / 1.0511)
P3	Medium alloy steel and heat treated steel	Rm 600-800 N/mm ²	(42CrMo4 / 1.7225)
P4	High alloy steel	Rm 800-1000 N/mm ²	(100Cr6 / 1.3505)
P5	Tool steel	Rm 900-1200 N/mm ²	(X210Cr12 / 1.2080 / K100)
P6	High tensile strength steel	Rm 1200-1600 N/mm ²	(X2NiCrMo18.9.5 / 1.6358 / W720)
M1	Ferritic stainless steel	Rm 400-700 N/mm ²	(X40Cr13 / 1.4034 / AISI420)
M2	Austenitic stainless steel (good machinability)	Rm 500-750 N/mm ²	(X5CrNi18.10 / 1.4301 / AISI304)
M3	Austenitic stainless steel (medium machinability)	Rm 550-850 N/mm ²	(X2CrNiMo18.12 / 1.4435 / AISI316L)
M4	Martensitic stainless steel	Rm 650-950 N/mm ²	(X2CrNiMoN25.7.4 / 1.4410 / Super Duplex)
M5	PH stainless steel	Rm 800-1250 N/mm ²	(X5CrNiNb16.4 / 1.4542 / 17-4PH)
K1	Grey cast iron	HB 150-250	(GG-25 / 0.6025)
K2	Nodular cast iron	HB 150-350	(GGG-50 / 0.7050)
K3	Austenitic cast iron	HB 120-260	(GGL-NiCr20.2 / 0.6660)
K4	ADI cast iron	HB 250-500	(GJS-1000-5 / ADI 1000)
N1	Aluminium alloys < 12% Si		(AlMgSi0.5 / 3.3206)
N2	Aluminium alloys > 12% Si		(AlSi12 / 3.2582)
N3	Copper alloys		(E-Cu57 / 2.0060)
N4	Brass alloys and bronze alloys		(CuZn20Al2 / 2.0460)
S1	Heat resistant super alloys HRSA (good machinability)	HRC < 25	(NiCr17Mo17FeW / 2.4802 / Hastelloy)
S2	Heat resistant super alloys HRSA (medium machinability)	HRC 25-35	(NiCr20Ti / 2.4630 / Nimonic 80)
S3	Heat resistant super alloys HRSA (low machinability)	HRC 35-45	(NiCr19Fe19NbMo / 2.4668 / Inconel 718)
S4	Low alloy titanium		(Ti99.6 / 3.7055 / Titanium grade 3)
S5	High alloy titanium		(Ti5Al2.5Sn / 3.7115 / Titanium grade 6)

Gr.	JP5520	JP5530	JP8525	JC8530	JP9525	JP9535	JC7515	JP7525	JC7530	JU6520	JU4525
P1	200 ÷ 250	180 ÷ 230	200 ÷ 250	240 ÷ 320							250 ÷ 350
P2	160 ÷ 220	150 ÷ 210	160 ÷ 220	200 ÷ 280							220 ÷ 300
P3	140 ÷ 200	120 ÷ 180	140 ÷ 200	180 ÷ 240							200 ÷ 280
P4	120 ÷ 160	100 ÷ 150	120 ÷ 160	140 ÷ 200							160 ÷ 220
P5	100 ÷ 140	80 ÷ 130	100 ÷ 140	120 ÷ 180							
P6	80 ÷ 120	60 ÷ 110	80 ÷ 120	100 ÷ 160							
M1	100 ÷ 160	90 ÷ 150			130 ÷ 220	120 ÷ 220					140 ÷ 240
M2	80 ÷ 140	80 ÷ 130			110 ÷ 180	100 ÷ 200					120 ÷ 200
M3	60 ÷ 120	60 ÷ 100			90 ÷ 160	120 ÷ 180					100 ÷ 180
M4					80 ÷ 140	90 ÷ 150					
M5					70 ÷ 120	80 ÷ 140					
K1							200 ÷ 350	150 ÷ 240	160 ÷ 300		250 ÷ 380
K2							180 ÷ 280	120 ÷ 200	140 ÷ 240		200 ÷ 300
K3							140 ÷ 200	100 ÷ 150	120 ÷ 180		160 ÷ 220
K4							120 ÷ 180		100 ÷ 150		
N1										400 ÷ 1000	
N2										300 ÷ 600	
N3										300 ÷ 500	
N4										200 ÷ 400	
S1						30 ÷ 60					
S2						30 ÷ 50					
S3						20 ÷ 40					
S4						50 ÷ 100					
S5						40 ÷ 80					

SEET12 SERIES

ISO inserts for face milling.

ISO

P

M

K

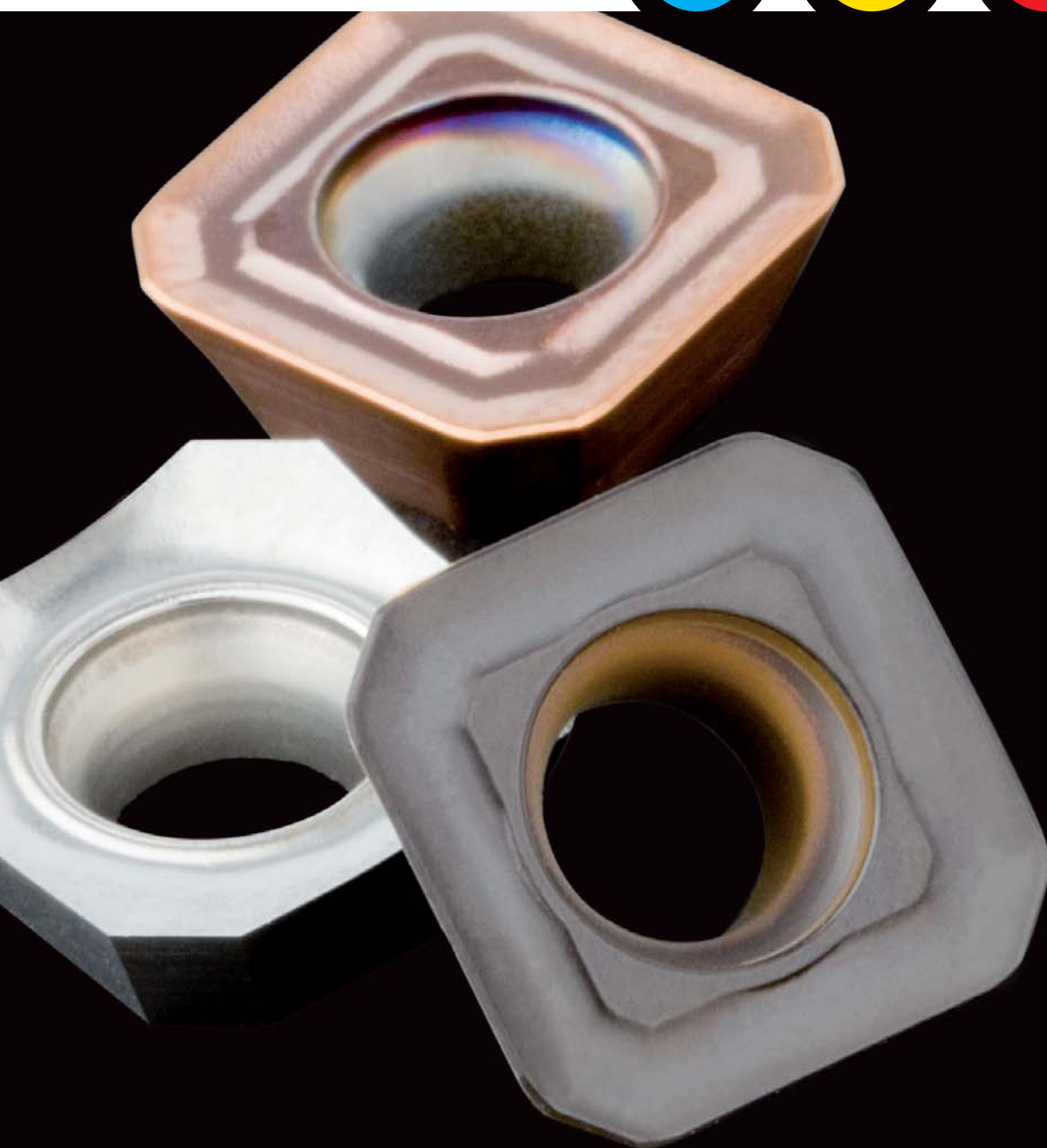

N



nixkoTOOLS

SEET12 SERIES

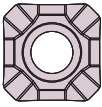
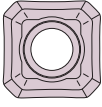
INSERTS

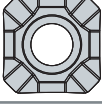
DESCRIPTION						HC				HW	HT				
		IC	T	b	Ød	JP5520	JC7530	JP8525	JC8530	JP9525	JU6520	JU4525			
SC	 SEET 1204AFEN-SC	12.70	4.76	2.50	5.50	●						●			
GP	 SEET 1204AFSN-GP	12.70	4.76	1.80	5.50			●	●	●					
(Flat)	 SEEW 1204AFSN	12.70	4.76	1.80	5.50		●								
AL	 POLISHED SEET 1204AFFN-AL	12.70	4.76	2.50	5.50						●				

● stock standard

HC: coated carbide

JP: PVD coating

HW: uncoated carbide

JC: CVD coating

HT: Cermet

JU: uncoated

GRADES APPLICATION CHART

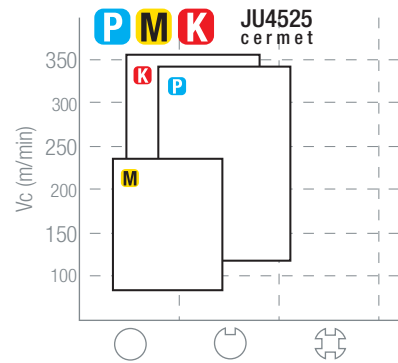
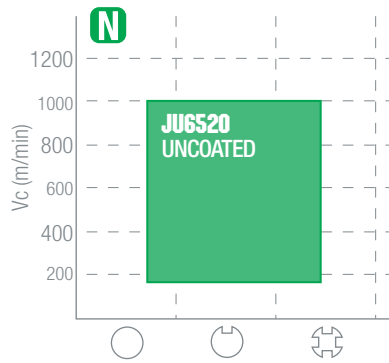
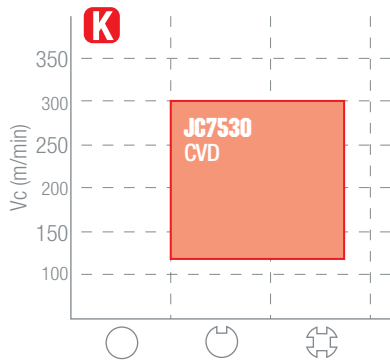
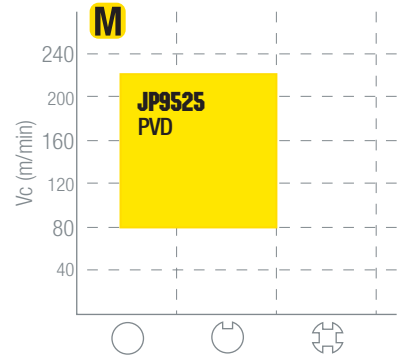
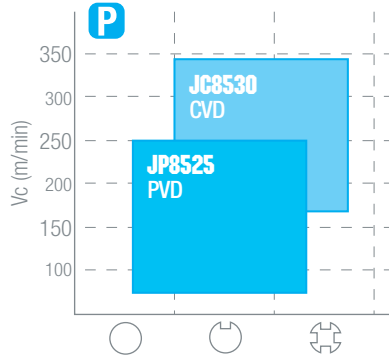
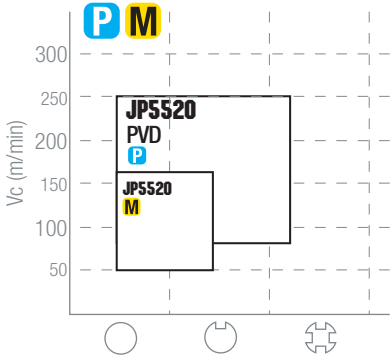

CHIPBREAKERS APPLICATION CHART

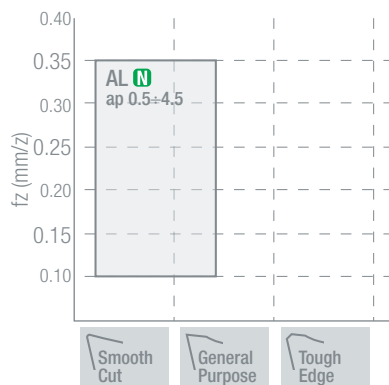
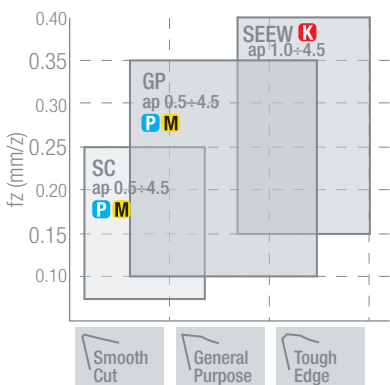

JU4525 cermet → fz-20%
Please reduce the feed rate by 20%

SEET12 SERIES

CUTTING SPEED (Vc m/min)

Gr.	MATERIAL		
P1	Free cutting steel and structural steel	Rm < 500 N/mm ²	(9SMn28 / 1.0715 / AVP)
P2	Carbon steel and low alloy steel	Rm 500-700 N/mm ²	(C40 / 1.0511)
P3	Medium alloy steel and heat treated steel	Rm 600-800 N/mm ²	(42CrMo4 / 1.7225)
P4	High alloy steel	Rm 800-1000 N/mm ²	(100Cr6 / 1.3505)
P5	Tool steel	Rm 900-1200 N/mm ²	(X210Cr12 / 1.2080 / K100)
P6	High tensile strength steel	Rm 1200-1600 N/mm ²	(X2NiCrMo18.9.5 / 1.6358 / W720)
M1	Ferritic stainless steel	Rm 400-700 N/mm ²	(X40Cr13 / 1.4034 / AISI420)
M2	Austenitic stainless steel (good machinability)	Rm 500-750 N/mm ²	(X5CrNi18.10 / 1.4301 / AISI304)
M3	Austenitic stainless steel (medium machinability)	Rm 550-850 N/mm ²	(X2CrNiMo18.12 / 1.4435 / AISI316L)
M4	Martensitic stainless steel	Rm 650-950 N/mm ²	(X2CrNiMoN25.7.4 / 1.4410 / Super Duplex)
M5	PH stainless steel	Rm 800-1250 N/mm ²	(X5CrNiNb16.4 / 1.4542 / 17-4PH)
K1	Grey cast iron	HB 150-250	(GG-25 / 0.6025)
K2	Nodular cast iron	HB 150-350	(GGG-50 / 0.7050)
K3	Austenitic cast iron	HB 120-260	(GGL-NiCr20.2 / 0.6660)
K4	ADI cast iron	HB 250-500	(GJS-1000-5 / ADI 1000)
N1	Aluminium alloys < 12% Si		(AlMgSi0.5 / 3.3206)
N2	Aluminium alloys > 12% Si		(AlSi12 / 3.2582)
N3	Copper alloys		(E-Cu57 / 2.0060)
N4	Brass alloys and bronze alloys		(CuZn20Al2 / 2.0460)

Gr.	JP5520	JP8525	JC8530	JP9525	JC7530	JU6520	JU4525
P1	200 ÷ 250	200 ÷ 250	240 ÷ 320				250 ÷ 350
P2	160 ÷ 220	160 ÷ 220	200 ÷ 280				220 ÷ 300
P3	140 ÷ 200	140 ÷ 200	180 ÷ 240				200 ÷ 280
P4	120 ÷ 160	120 ÷ 160	140 ÷ 200				160 ÷ 220
P5	100 ÷ 140	100 ÷ 140	120 ÷ 180				
P6	80 ÷ 120	80 ÷ 120	100 ÷ 160				
M1	100 ÷ 160			130 ÷ 220			140 ÷ 240
M2	80 ÷ 140			110 ÷ 180			120 ÷ 200
M3	60 ÷ 120			90 ÷ 160			100 ÷ 180
M4				80 ÷ 140			
M5				70 ÷ 120			
K1					160 ÷ 300		250 ÷ 380
K2					140 ÷ 240		200 ÷ 300
K3					120 ÷ 180		160 ÷ 220
K4					100 ÷ 150		
N1						400 ÷ 1000	
N2						300 ÷ 600	
N3						300 ÷ 500	
N4						200 ÷ 400	



REK PLUS SERIES

The all-around solution for shouldering.

ISO

P

M

K

N

S



New **helical** type for
extremely high performance

nixkoTOOLS

REKPLUS SERIES

HOLDERS

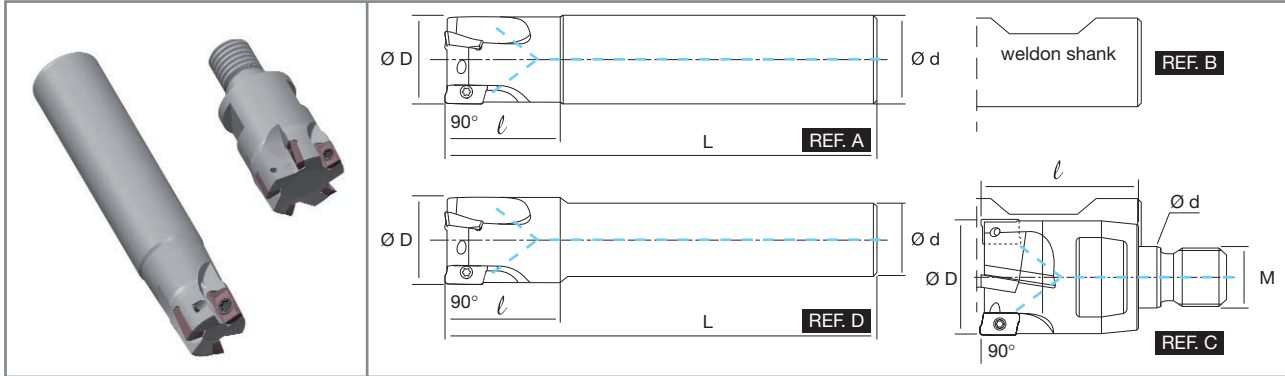

INSERTS	DESCRIPTION				STOCK	DIMENSIONS					REF	👉	🔩	🔧	TORQUE Nm
	NEW	OLD	ØD	Z		Ød	L	l							
NT-RKP11	NT-RKP11	D0155-S16-Z2	NT-AP11H	D0155-S16-Z2	★	15.5	2	16	100	28	A	✓	NT-ST018	NT-FTB08	1.20
		D016-S16-Z2		●	16	2	16	100	28	A	✓	NT-ST018	NT-FTB08	1.20	
		D016-S16-Z2-L150		●	16	2	16	150	28	A	✓	NT-ST018	NT-FTB08	1.20	
		D016-W16-Z2-L080		●	16	2	16	80	28	B	✓	NT-ST018	NT-FTB08	1.20	
		D020-S16-Z3		●	20	3	16	110	28	D	✓	NT-ST018	NT-FTB08	1.20	
		D020-S20-Z3		●	20	3	20	110	28	A	✓	NT-ST018	NT-FTB08	1.20	
		D020-S20-Z3-L200		●	20	3	20	200	28	A	✓	NT-ST018	NT-FTB08	1.20	
		D020-W20-Z3-L090		●	20	3	20	90	28	B	✓	NT-ST018	NT-FTB08	1.20	
		D025-S20-Z3		●	25	3	20	120	35	D	✓	NT-ST018	NT-FTB08	1.20	
		D025-S25-Z3		●	25	3	25	120	35	A	✓	NT-ST018	NT-FTB08	1.20	
		D025-S25-Z4		●	25	4	25	120	35	A	✓	NT-ST018	NT-FTB08	1.20	
		D025-W25-Z4-L100		●	25	4	25	100	35	B	✓	NT-ST018	NT-FTB08	1.20	
		D032-S25-Z4		●	32	4	25	130	35	D	✓	NT-ST018	NT-FTB08	1.20	
		D032-S32-Z4		★	32	4	32	130	35	A	✓	NT-ST018	NT-FTB08	1.20	
D032-S32-Z5	★	32	5	32	130	35	A	✓	NT-ST018	NT-FTB08	1.20				
NT-RKP16	NT-RKP16	D025-S25-Z2	NT-AP16H	D025-S25-Z2	★	25	2	25	120	40	A	✓	NT-ST019	NT-FTB15	3.50
		D032-S32-Z3		★	32	3	32	130	45	A	✓	NT-ST017	NT-FTB15	3.50	
		D040-S32-Z4		★	40	4	32	150	40	A	✓	NT-ST017	NT-FTB15	3.50	

● stock standard; ★ upcoming introduction

MODULAR TYPE

INSERTS	DESCRIPTION				STOCK	DIMENSIONS					REF	👉	🔩	🔧	TORQUE Nm
	NEW	OLD	ØD	Z		Ød	M	l							
NT-RKP11	NT-RKP11	D016-M08-Z2	NT-AP11H	D016-M08-Z2	★	16	2	8.5	M8	25	C	✓	NT-ST018	NT-FTB08	1.20
		D020-M10-Z2		★	20	2	10.5	M10	30	C	✓	NT-ST018	NT-FTB08	1.20	
		D020-M10-Z3		●	20	3	10.5	M10	30	C	✓	NT-ST018	NT-FTB08	1.20	
		D025-M12-Z3		★	25	3	12.5	M12	35	C	✓	NT-ST018	NT-FTB08	1.20	
		D025-M12-Z4		★	25	4	12.5	M12	35	C	✓	NT-ST018	NT-FTB08	1.20	
		D032-M16-Z4		★	32	4	16.5	M16	43	C	✓	NT-ST018	NT-FTB08	1.20	
		D032-M16-Z5		●	32	5	16.5	M16	43	C	✓	NT-ST018	NT-FTB08	1.20	

● stock standard; ★ upcoming introduction



We will continue to supply the equivalent milling cutters without coolant holes (description: NT-AP11 and NT-AP16) until availability of items marked with ★.

HOLDERS

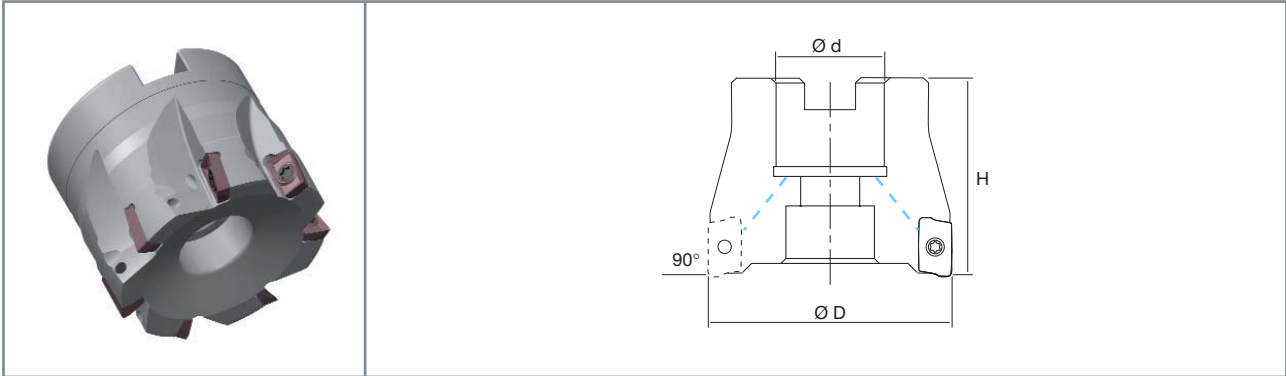

INSERTS	DESCRIPTION				STOCK	DIMENSIONS				Lubrication	Screw	Key	TORQUE Nm
	NEW	OLD				ØD	Z	Ød	H				
NT-RKP11	NT-RKP11	D040-F16-Z5	NT-AP11H	D040-F16-Z5	●	40	5	16	40	✓	NT-ST018	NT-FTB08	1.20
		D040-F16-Z6		D040-F16-Z6	●	40	6	16	40	✓	NT-ST018	NT-FTB08	1.20
		D050-F22-Z5		D050-F22-Z5	★	50	5	22	40	✓	NT-ST018	NT-FTB08	1.20
		D050-F22-Z7		D050-F22-Z7	★	50	7	22	40	✓	NT-ST018	NT-FTB08	1.20
		D063-F22-Z6		D063-F22-Z6	●	63	6	22	40	✓	NT-ST018	NT-FTB08	1.20
		D063-F22-Z8		D063-F22-Z8	●	63	8	22	40	✓	NT-ST018	NT-FTB08	1.20
		D080-F27-Z7		D080-F27-Z7	●	80	7	27	50	✓	NT-ST018	NT-FTB08	1.20
		D080-F27-Z10		D080-F27-Z10	●	80	10	27	50	✓	NT-ST018	NT-FTB08	1.20
NT-RKP16	NT-RKP16	D040-F16-Z4	NT-AP16H	D040-F16-Z4	●	40	4	16	40	✓	NT-ST017	NT-FTB15	3.50
		D050-F22-Z4		D050-F22-Z4	★	50	4	22	50	✓	NT-ST017	NT-FTB15	3.50
		D050-F22-Z5		D050-F22-Z5	●	50	5	22	50	✓	NT-ST017	NT-FTB15	3.50
		D063-F22-Z5		D063-F22-Z5	●	63	5	22	50	✓	NT-ST017	NT-FTB15	3.50
		D063-F22-Z6		D063-F22-Z6	★	63	6	22	50	✓	NT-ST017	NT-FTB15	3.50
		D080-F27-Z6		D080-F27-Z6	★	80	6	27	50	✓	NT-ST017	NT-FTB15	3.50
		D080-F27-Z8		D080-F27-Z8	★	80	8	27	50	✓	NT-ST017	NT-FTB15	3.50
		D100-F32-Z8		D100-F32-Z8	●	100	8	32	50	✓	NT-ST017	NT-FTB15	3.50

● stock standard; ★ upcoming introduction



We will continue to supply the equivalent milling cutters without coolant holes (description: NT-AP11 and NT-AP16) until availability of items marked with ★.

REKPLUS SERIES

INSERTS

		DESCRIPTION		RADIUS	HC							HW	HT		
					JP5520	JP5530	JP8625	JP9535	JP9635	JC7515	JP7615	JP7525	JU6520	JU4525	
					NEW	OLD									
STRAIGHT TYPE	SC		NT-RKP 11R08M-SC	APMT 113508ER-SC	0.8	●	●		★						
			NT-RKP 16R08M-SC	APMT 160408ER-SC	0.8	●	●		★						
	GP		NT-RKP 11R08M-GP	APMT 113508ER-GP	0.8	●	●		★		●		●		●
			NT-RKP 16R08M-GP	APMT 160408ER-GP	0.8	●	●		★		●		●		●
	TE		NT-RKP 11R08M-TE	APMT 113508ER-TE	0.8	●	●					●			
			NT-RKP 16R08M-TE	APMT 160408ER-TE	0.8	●	●					●			
AL		POLISHED	NT-RKP 11R04G-AL	APGT 113504FR-AL	0.4								●		
			11R08G-AL	113508FR-AL	0.8								●		
			NT-RKP 16R08G-AL	APGT 160408FR-AL	0.8								●		
HELICAL TYPE	HSC		New	NT-RKP 11R04M-HSC	-	0.4			★		★				
			NT-RKP 11R08M-HSC	-	0.8			●		●					
			NT-RKP 11R12M-HSC	-	1.2			★		★					
			NT-RKP 16R08M-HSC	-	0.8			●		●					
			NT-RKP 16R12M-HSC	-	1.2			★		★					
			NT-RKP 16R16M-HSC	-	1.6			★		★					
	HGP		New	NT-RKP 11R04M-HGP	-	0.4			★		★				
			NT-RKP 11R08M-HGP	-	0.8			●		●		●			
			NT-RKP 11R12M-HGP	-	1.2			★		★					
			NT-RKP 11R16M-HGP	-	1.6			★		★					
			NT-RKP 16R08M-HGP	-	0.8			●		●		●			
			NT-RKP 16R12M-HGP	-	1.2			★		★					
			NT-RKP 16R16M-HGP	-	1.6			★		★					
			NT-RKP 16R20M-HGP	-	2.0			★		★					
NT-RKP 16R31M-HGP	-	3.1			★		★								

● stock standard; ★ upcoming introduction

HC: coated carbide

HW: uncoated carbide

HT: cermet

JP: PVD coating

JC: CVD coating

JU: uncoated

A NEW GENERATION OF INSERTS FOR EXTREMELY HIGH PERFORMANCE

HELICAL TYPE	CUTTING EDGE PROFILE	NO SIGNS ON SHOULDERING WALL	EXCELLENT SURFACE FINISHING

(material: C40; Vc: 180m/min; fz: 0.08mm/z; ap: 5mm; ae: 0.6mm)

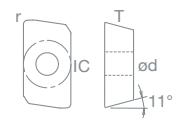

NT-RKP11	NT-RKP16
IC 6.35	IC 9.53
T 3.50	T 4.76
Ød 2.80	Ød 4.50

GRADES APPLICATION CHART

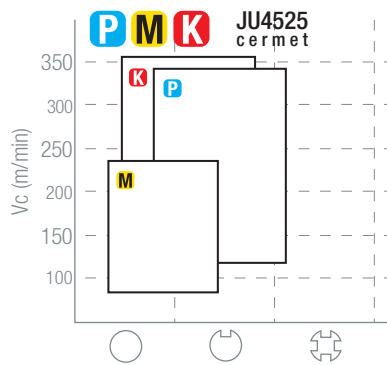
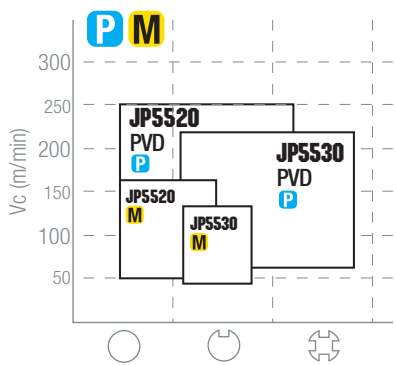
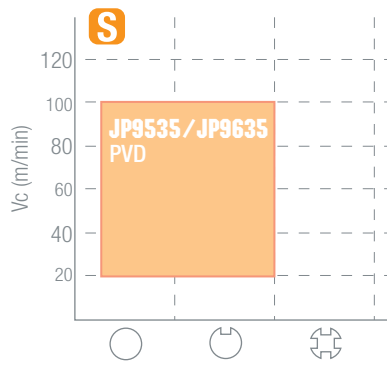
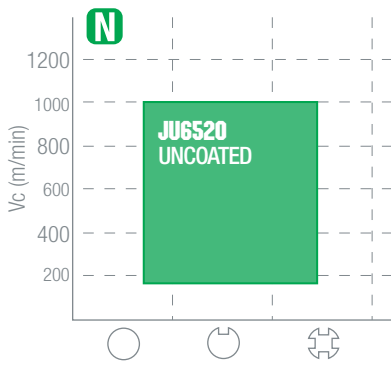
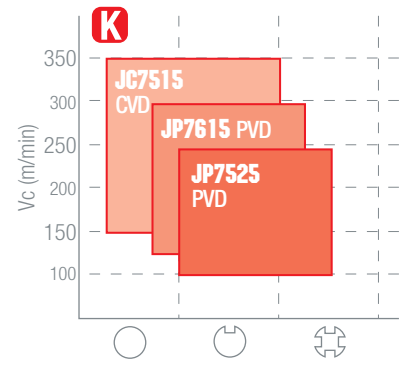
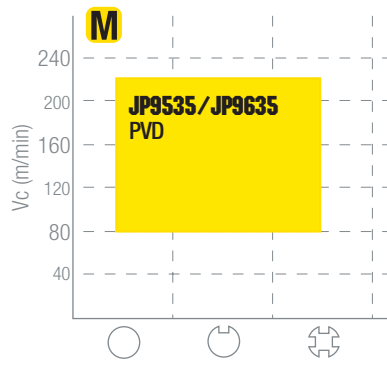

REKPLUS SERIES

CHIPBREAKERS APPLICATION CHART

NT-RKP11

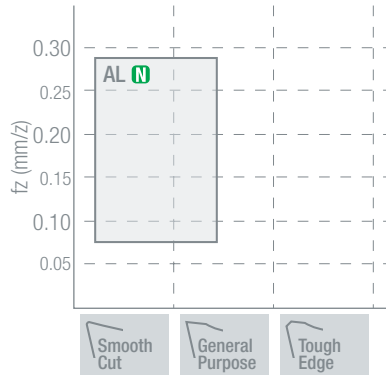
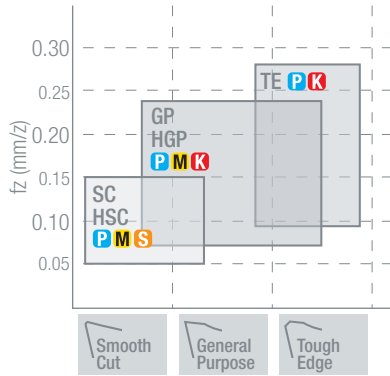

NT-RKP16

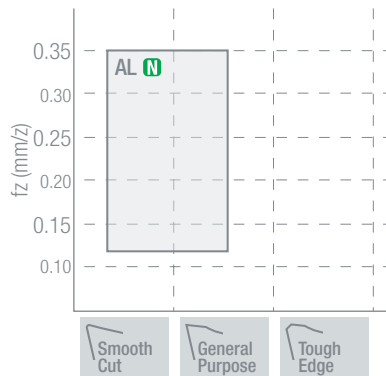
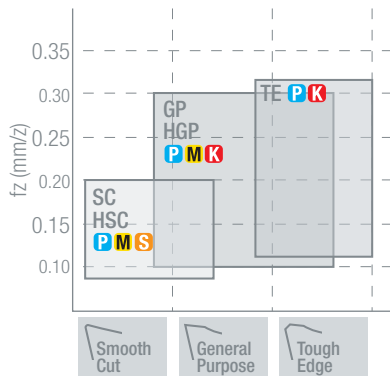

JU4525 cermet → fz-20%
Please reduce the feed rate by 20%

CUTTING SPEED (Vc m/min)

Gr.	MATERIAL		
P1	Free cutting steel and structural steel	Rm < 500 N/mm ²	(9SMn28 / 1.0715 / AVP)
P2	Carbon steel and low alloy steel	Rm 500-700 N/mm ²	(C40 / 1.0511)
P3	Medium alloy steel and heat treated steel	Rm 600-800 N/mm ²	(42CrMo4 / 1.7225)
P4	High alloy steel	Rm 800-1000 N/mm ²	(100Cr6 / 1.3505)
P5	Tool steel	Rm 900-1200 N/mm ²	(X210Cr12 / 1.2080 / K100)
P6	High tensile strength steel	Rm 1200-1600 N/mm ²	(X2NiCrMo18.9.5 / 1.6358 / W720)
M1	Ferritic stainless steel	Rm 400-700 N/mm ²	(X40Cr13 / 1.4034 / AISI420)
M2	Austenitic stainless steel (good machinability)	Rm 500-750 N/mm ²	(X5CrNi18.10 / 1.4301 / AISI304)
M3	Austenitic stainless steel (medium machinability)	Rm 550-850 N/mm ²	(X2CrNiMo18.12 / 1.4435 / AISI316L)
M4	Martensitic stainless steel	Rm 650-950 N/mm ²	(X2CrNiMoN25.7.4 / 1.4410 / Super Duplex)
M5	PH stainless steel	Rm 800-1250 N/mm ²	(X5CrNiNb16.4 / 1.4542 / 17-4PH)
K1	Grey cast iron	HB 150-250	(GG-25 / 0.6025)
K2	Nodular cast iron	HB 150-350	(GGG-50 / 0.7050)
K3	Austenitic cast iron	HB 120-260	(GGL-NiCr20.2 / 0.6660)
K4	ADI cast iron	HB 250-500	(GJS-1000-5 / ADI 1000)
N1	Aluminium alloys < 12% Si		(AlMgSi0.5 / 3.3206)
N2	Aluminium alloys > 12% Si		(AlSi12 / 3.2582)
N3	Copper alloys		(E-Cu57 / 2.0060)
N4	Brass alloys and bronze alloys		(CuZn20Al2 / 2.0460)
S1	Heat resistant super alloys HRSA (good machinability)	HRC < 25	(NiCr17Mo17FeW / 2.4802 / Hastelloy)
S2	Heat resistant super alloys HRSA (medium machinability)	HRC 25-35	(NiCr20Ti / 2.4630 / Nimonic 80)
S3	Heat resistant super alloys HRSA (low machinability)	HRC 35-45	(NiCr19Fe19NbMo / 2.4668 / Inconel 718)
S4	Low alloy titanium		(Ti99.6 / 3.7055 / Titanium grade 3)
S5	High alloy titanium		(Ti5Al2.5Sn / 3.7115 / Titanium grade 6)

Gr.	JP5520	JP5530	JP8625	JP9535	JP9635	JC7515	JP7615	JP7525	JU6520	JU4525
P1	200 ÷ 250	180 ÷ 230	200 ÷ 250							250 ÷ 350
P2	160 ÷ 220	150 ÷ 210	160 ÷ 220							220 ÷ 300
P3	140 ÷ 200	120 ÷ 180	140 ÷ 200							200 ÷ 280
P4	120 ÷ 160	100 ÷ 150	120 ÷ 160							160 ÷ 220
P5	100 ÷ 140	80 ÷ 130	100 ÷ 140							
P6	80 ÷ 120	60 ÷ 110	80 ÷ 120							
M1	100 ÷ 160	90 ÷ 150		120 ÷ 220	120 ÷ 220					140 ÷ 240
M2	80 ÷ 140	80 ÷ 130		100 ÷ 200	100 ÷ 200					120 ÷ 200
M3	60 ÷ 120	60 ÷ 100		120 ÷ 180	120 ÷ 180					100 ÷ 180
M4				90 ÷ 150	90 ÷ 150					
M5				80 ÷ 140	80 ÷ 140					
K1						200 ÷ 350	160 ÷ 250	150 ÷ 240		250 ÷ 380
K2						180 ÷ 280	140 ÷ 220	120 ÷ 200		200 ÷ 300
K3						140 ÷ 200	120 ÷ 160	100 ÷ 150		160 ÷ 220
K4						120 ÷ 180				
N1									400 ÷ 1000	
N2									300 ÷ 600	
N3									300 ÷ 500	
N4									200 ÷ 400	
S1				30 ÷ 60	30 ÷ 60					
S2				30 ÷ 50	30 ÷ 50					
S3				20 ÷ 40	20 ÷ 40					
S4				50 ÷ 100	50 ÷ 100					
S5				40 ÷ 80	40 ÷ 80					



APKT SERIES

Worldwide standard for shouldering.

ISO **P** **M** **K** **N**

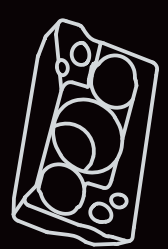

2 edges

nixkoTOOLS

APKT SERIES

HOLDERS

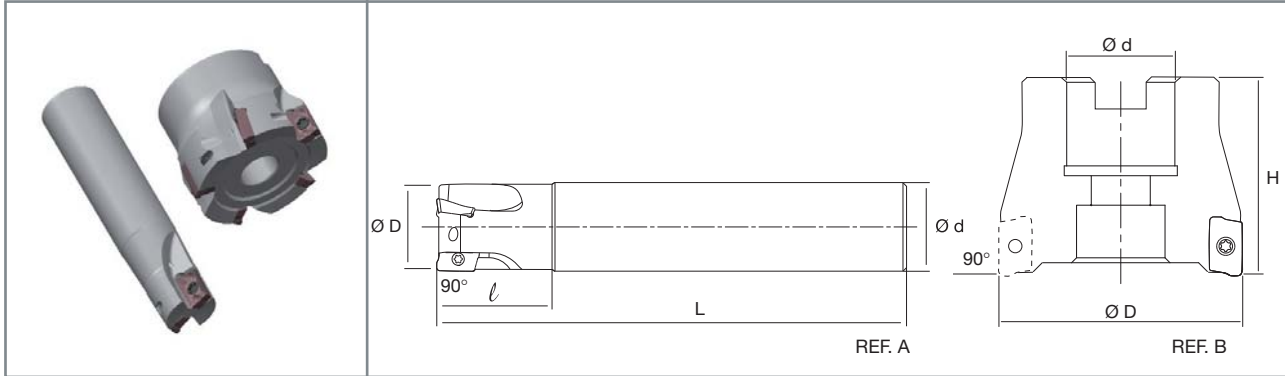

APKT	DESCRIPTION	STOCK	DIMENSIONS							REF	🔧	🔩	🔑	TORQUE Nm				
			ØD	Z	Ød	L	ℓ	H										
APKT1003	NT-APK10H D016-S16-Z2	●	16	2	16	100	28	-	A	✓	NT-ST011	NT-FTB09	1.2					
	D020-S20-Z3	●	20	3	20	110	30	-	A	✓	NT-ST011	NT-FTB09	1.2					
	D025-S25-Z3	●	25	3	25	120	30	-	A	✓	NT-ST011	NT-FTB09	1.2					
	D032-S32-Z4	●	32	4	32	130	40	-	A	✓	NT-ST011	NT-FTB09	1.2					
	D040-F16-Z5	●	40	5	16	-	-	40	B	✓	NT-ST011	NT-FTB09	1.2					
	D050-F22-Z5	●	50	5	22	-	-	50	B	✓	NT-ST011	NT-FTB09	1.2					
	D050-F22-Z7	●	50	7	22	-	-	50	B	✓	NT-ST011	NT-FTB09	1.2					
APKT1604	NT-APK16H D025-S25-Z2	●	25	2	25	120	40	-	A	✓	NT-ST019	NT-FTB15	3.5					
	D032-S32-Z3	●	32	3	32	130	45	-	A	✓	NT-ST019	NT-FTB15	3.5					
	D040-F16-Z4	●	40	4	16	-	-	40	B	✓	NT-ST019	NT-FTB15	3.5					
	D050-F22-Z4	●	50	4	22	-	-	50	B	✓	NT-ST019	NT-FTB15	3.5					
	D050-F22-Z5	●	50	5	22	-	-	50	B	✓	NT-ST019	NT-FTB15	3.5					
	D063-F22-Z5	●	63	5	22	-	-	50	B	✓	NT-ST019	NT-FTB15	3.5					
	D063-F22-Z6	●	63	6	22	-	-	50	B	✓	NT-ST019	NT-FTB15	3.5					
	D080-F27-Z6	●	80	6	27	-	-	50	B	✓	NT-ST019	NT-FTB15	3.5					

● stock standard

INSERTS

	DESCRIPTION							HC					HW				
		IC	T	r	b	Ød		JP8525	JC8530	JP9525	JC7530	JU6520					
GP	APKT 1003PDSR-GP	6.70	3.18	0.4	0.90	2.80	●	●	●	●							
	1604PDSR-GP	9.525	4.76	0.8	1.30	4.40	●	●	●	●							
TE	APKT 1003PDSR-TE	6.70	3.18	0.4	0.90	2.80	●	●	●	●							
	1604PDSR-TE	9.53	4.76	0.8	1.30	4.40	●	●	●	●							
AL	APKT 1003PDFR-AL	6.70	3.18	0.4	1.60	2.80					●						
	1604PDFR-AL	9.53	4.76	0.8	1.90	4.40					●						

● stock standard

HC: coated carbide
HW: uncoated carbide

JP: PVD coating
JC: CVD coating
JU: uncoated

GRADES APPLICATION CHART

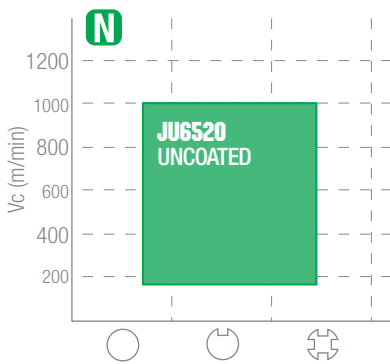
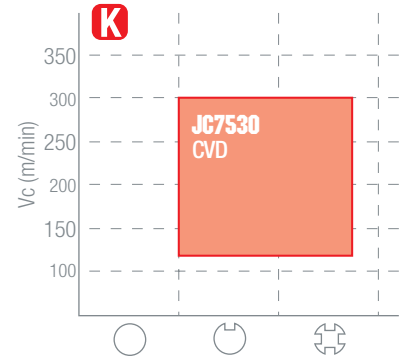
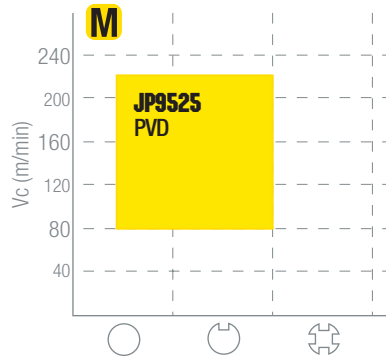
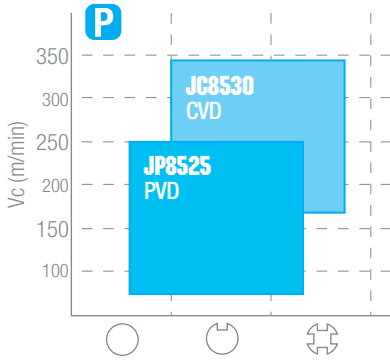

CHIPBREAKERS APPLICATION CHART

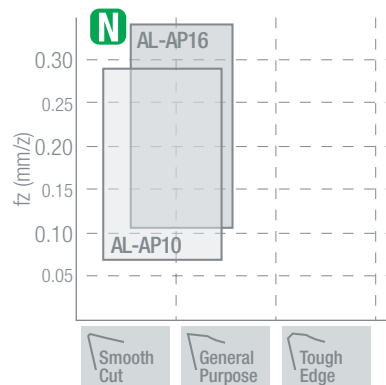
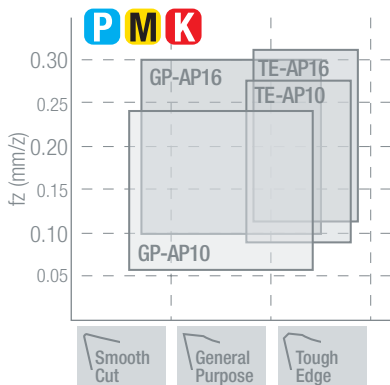

CUTTING SPEED (Vc m/min)

Gr.	MATERIAL		
P1	Free cutting steel and structural steel	Rm < 500 N/mm ²	(9SMn28 / 1.0715 / AVP)
P2	Carbon steel and low alloy steel	Rm 500-700 N/mm ²	(C40 / 1.0511)
P3	Medium alloy steel and heat treated steel	Rm 600-800 N/mm ²	(42CrMo4 / 1.7225)
P4	High alloy steel	Rm 800-1000 N/mm ²	(100Cr6 / 1.3505)
P5	Tool steel	Rm 900-1200 N/mm ²	(X210Cr12 / 1.2080 / K100)
P6	High tensile strength steel	Rm 1200-1600 N/mm ²	(X2NiCrMo18.9.5 / 1.6358 / W720)
M1	Ferritic stainless steel	Rm 400-700 N/mm ²	(X40Cr13 / 1.4034 / AISI420)
M2	Austenitic stainless steel (good machinability)	Rm 500-750 N/mm ²	(X5CrNi18.10 / 1.4301 / AISI304)
M3	Austenitic stainless steel (medium machinability)	Rm 550-850 N/mm ²	(X2CrNiMo18.12 / 1.4435 / AISI316L)
M4	Martensitic stainless steel	Rm 650-950 N/mm ²	(X2CrNiMoN25.7.4 / 1.4410 / Super Duplex)
M5	PH stainless steel	Rm 800-1250 N/mm ²	(X5CrNiNb16.4 / 1.4542 / 17-4PH)
K1	Grey cast iron	HB 150-250	(GG-25 / 0.6025)
K2	Nodular cast iron	HB 150-350	(GGG-50 / 0.7050)
K3	Austenitic cast iron	HB 120-260	(GGL-NiCr20.2 / 0.6660)
K4	ADI cast iron	HB 250-500	(GJS-1000-5 / ADI 1000)
N1	Aluminium alloys < 12% Si		(AlMgSi0.5 / 3.3206)
N2	Aluminium alloys > 12% Si		(AlSi12 / 3.2582)
N3	Copper alloys		(E-Cu57 / 2.0060)
N4	Brass alloys and bronze alloys		(CuZn20Al2 / 2.0460)

Gr.	JP8525	JC8530	JP9525	JC7530	JU6520
P1	200 ÷ 250	260 ÷ 330			
P2	170 ÷ 210	220 ÷ 280			
P3	140 ÷ 170	180 ÷ 220			
P4	110 ÷ 140	140 ÷ 180			
P5	70 ÷ 100	100 ÷ 120			
P6	60 ÷ 80	80 ÷ 100			
M1			130 ÷ 220		
M2			110 ÷ 180		
M3			90 ÷ 150		
M4			80 ÷ 140		
M5			70 ÷ 120		
K1				160 ÷ 280	
K2				140 ÷ 240	
K3				120 ÷ 160	
K4				80 ÷ 140	
N1					400 ÷ 1000
N2					300 ÷ 600
N3					300 ÷ 500
N4					200 ÷ 400

nikkotools

Sorma Spa
Via Don F. Tosatto, 8
30174 Mestre - Venezia
+39 041.959179

info@nikkotools.com
www.nikkotools.com



2 099999 784488