

TORRETTE
TURRETS
REVOLVER

SAUTER VDI 30 DIN-5480

TORRETTE ASSIALI
AXIAL TURRETS
AXIAL REVOLVER

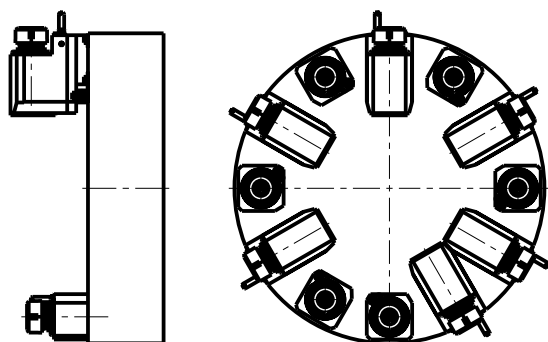

TORRETTE RADIALI
RADIAL TURRETS
RADIAL REVOLVER

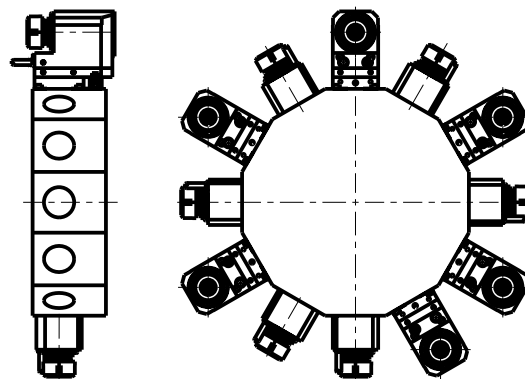

MACCHINE MACHINES MASCHINEN	MODELLI MODELS MODELLE
COLCHESTER	T 6 MS - T 8 MSY
DOOSAN	S 240 LM - S 310 M - Z 290 M - Z 340
EMCO	E 45 - E 65 TCM - 345 II - 365/465 MC - Hyperturn 645/665/690 MC - Maxxturn 65
GILDEMEISTER	Alpha 300/500 - Beta 500/800/1250 - CTX 210/310/410/320/420 - CTV 160 - GM 70 - MF Twin 42/65 - NEF 400 - Twin 42/65/102 - Sprint 50/65
GOODWAY	GT - S20
GRAZIANO	GP 50/70 - GT 300 - GT 300/400 G - MT 400 - Twin 50/70
HARDINGE	Elite 8/51 - Talent 6/45 - Talent 8/52
HURCO	TMM 8
MAGDEBURGER	MV 100
MONFORTS	DNC 3
NILES	NF 13/16/20 - NV 20
SAEILO	Contur TSL 300
SHAUBLIN	42 L TM/TMI - 65 TM/TM-3Y/TMI
SCHERER FEINBAU	VDZ 120/150
SCHUSTER	Futureline 350 - VTM 350/650
SPINNER	UP 65 SMC
VICTOR	VT II 16/20 - VT A16/A20 SCV/YSCV
WEILER	DZ 45 H - DZ 67
WEISSER	Univertor C
WIA	SKT 150 SY

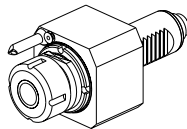
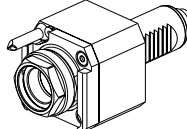
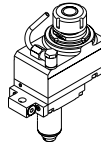
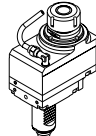
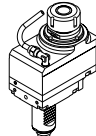
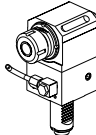
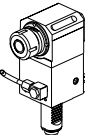
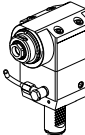
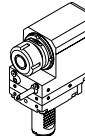
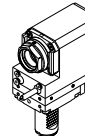
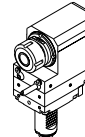
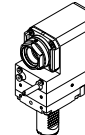
		PAGINA Page Seite
MODULO MOTORIZZATO ASSIALE VDI30 DIN 5480 Axial driven tool VDI30 DIN 5480 Axial angetriebenes Werkzeug VDI30 DIN 5480		SAU017.2.00
MODULO MOTORIZZATO ASSIALE MTSK VDI30 DIN 5480 Axial MTSK driven tool VDI30 DIN 5480 Axial MTSK angetriebenes Werkzeug VDI30 DIN 5480		SAU017.2.00.K
MODULO MOTORIZZATO ASSIALE DISASSATO 36mm VDI30 DIN 5480 Axial driven tool re-directed by 36mm VDI30 DIN 5480 Axial angetriebenes Werkzeug achsversetzt um 36mm VDI30 DIN 5480		SAU017.2.05
MODULO MOTOR. ASSIALE RIDOTTO I=2:1 DISASSATO 36mm VDI30 DIN 5480 Axial geared-down I=2:1 driven tool re-directed by 36mm VDI30 DIN 5480 Axial angetriebenes Werkzeug untersetzt I=2:1 achsversetzt um 36mm VDI30 DIN 5480		SAU017.2.30
MODULO MOTOR. ASSIALE MOLTIPLICATO I=1:2 DISASSATO 36mm VDI30 DIN 5480 Axial geared-up I=1:2 driven tool re-directed by 36mm VDI30 DIN 5480 Axial angetriebenes Werkzeug uebersetzt I=1:2 achsversetzt um 36mm VDI30 DIN 5480		SAU017.2.60
MODULO MOTORIZZATO RADIALE VDI30 DIN 5480 H=85mm Radial driven tool VDI30 DIN 5480 H=85mm Radial angetriebenes Werkzeug VDI30 DIN 5480 H=85mm		SAU018.2.00
MODULO MOTORIZZATO RADIALE VDI30 DIN 5480 H=100mm Radial driven tool VDI30 DIN 5480 H=100mm Radial angetriebenes Werkzeug VDI30 DIN 5480 H=100mm		SAU018.2.10
MODULO MOTORIZ. RADIALE MOLTIPLICATO I = 1:2 VDI30 DIN5480 Radial geared-up I=1:2 driven tool VDI30 DIN 5480 Radial angetriebenes Werkzeug uebersetzt I=1:2 VDI30 DIN 5480		SAU018.2.13
MODULO MOTORIZZATO RADIALE ARRETRATO VDI30 DIN 5480 H=75mm Radial rear-set driven tool VDI30 DIN 5480 H=75mm Radial angetriebenes Werkzeug zurueckversetzt VDI30 DIN 5480 H=75mm		SAU018.2.60
MODULO MOTORIZZ. RADIALE ARRETRATO MTSK VDI30 DIN 5480 H=75mm Radial MTSK rear-set driven tool VDI30 DIN 5480 H=75mm Radial MTSK angetriebenes Werkzeug zurueckversetzt VDI30 DIN 5480 H=75mm		SAU018.2.60.K
MODULO MOTORIZZATO RADIALE ARRETRATO VDI30 DIN 5480 H=85mm Radial rear-set driven tool VDI30 DIN 5480 H=85mm Radial angetriebenes Werkzeug zurueckversetzt VDI30 DIN 5480 H=85mm		SAU018.2.70
MODULO MOTORIZZ. RADIALE ARRETRATO MTSK VDI30 DIN 5480 H=85mm Radial MTSK rear-set driven tool VDI30 DIN 5480 H=85mm Radial MTSK angetriebenes Werkzeug zurueckversetzt VDI30 DIN 5480 H=85mm		SAU018.2.70.K

SAUTER VDI 30 DIN-5480

		PAGINA Page Seite
<p>MODULO MOTORIZZATO RADIALE ARRETRATO VDI30 DIN 5480 H=100mm Radial rear-set driven tool VDI30 DIN 5480 H=100mm Radial angetriebenes Werkzeug zurueckversetzt VDI30 DIN 5480 H=100mm</p>		SAU018.2.80
<p>MODULO MOTORIZZ. RADIALE ARRETRATO MTSK VDI30 DIN 5480 H=100mm Radial MTSK rear-set driven tool VDI30 DIN 5480 H=100mm Radial MTSK angetriebenes Werkzeug zurueckversetzt VDI30 DIN 5480 H=100mm</p>		SAU018.2.80.K
<p>MODULO MOTORIZZATO RADIALE BISPORGENTE VDI30 DIN 5480 H=85mm Radial opposite face twin driven tool VDI30 DIN 5480 H=85mm Radial angetriebenes Werkzeug halb vorspringend VDI30 DIN 5480 H=85mm</p>		SAU019.2.00
<p>MODULO MOTORIZZATO RADIALE BISPORGENTE VDI30 DIN 5480 H=100mm Radial opposite face twin driven tool VDI30 DIN 5480 H=100mm Radial angetriebenes Werkzeug halb vorspringend VDI30 DIN 5480 H=100mm</p>		SAU019.2.10
<p>MODULO MOTORIZZATO ORIENTABILE ±90° VDI30 DIN 5480 ±90° adjustable angle driven tool VDI30 DIN 5480 Angetriebenes Werkzeug schwenkbar ±90° VDI30 DIN 5480</p>		SAU335.2.00
<p>MODULO MOTORIZZATO PORTACREATORE VDI30 DIN 5480 Driven gear hobber VDI30 DIN 5480 Angetriebenes Zahnradwaelzfraes-Werkzeug VDI30 DIN 5480</p>		SAU340.2.05

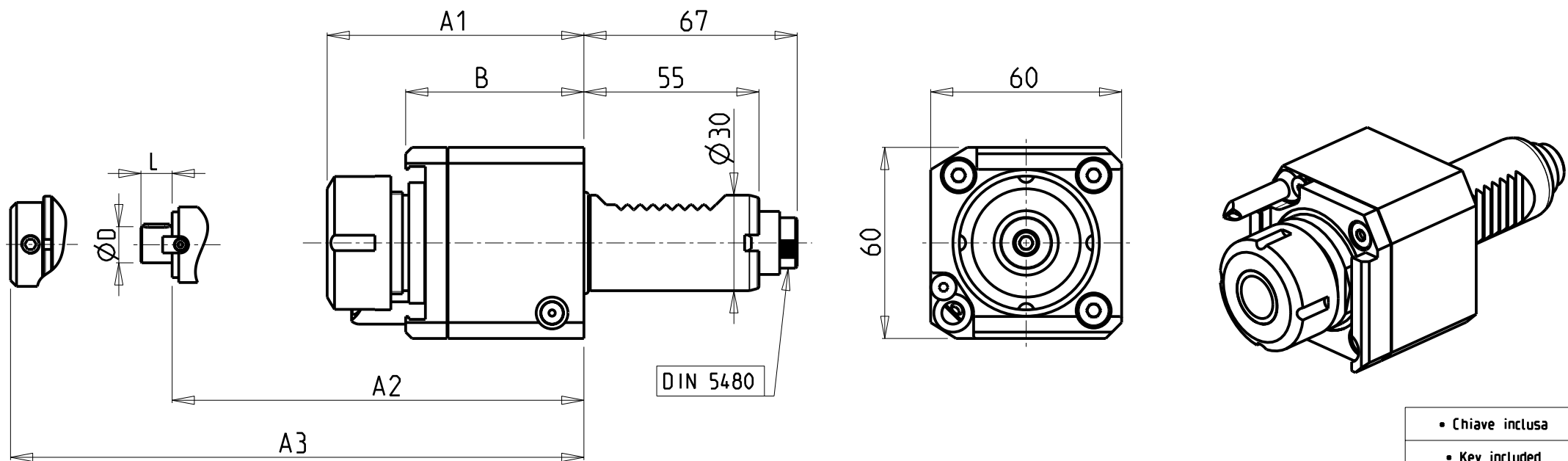

- Chiave inclusa
- Key included
- Schlüssel inbegriffen

Cod. MT	Mandrino Spindle Spindel	I	RPM	Coppia Max Max Torque Max Drehmoment	Lubrificazione int. Coolant through Innenkuehlung	Lubrificazione est. Ext. coolant Aussenkuehlung	ØD	L	A1	A2	A3	B	CHIAVI NON INCLUDE Keys not included Schlüssel nicht einbegriffen		
SAU0070125	ER25	1:1	6000	32Nm		X			80.66			45	OKU0290009	CHSTER25	-
SAU0071125	ER25	1:1	6000	32Nm	P=30bar	X			94.66			59	OKU0290009	CHSTER25	-
SAU0070225	ERA25	1:1	6000	32Nm		X			70.03			45	OKU0290009	CHUB27	CHTAER25ZC
SAU0071225	ERA25	1:1	6000	32Nm	P=30bar	X			84.03			59	OKU0290009	CHUB27	CHTAER25ZC
SAU0070316	WELDON16	1:1	6000	32Nm		X					66.5	45	-	-	-
SAU0071316	WELDON16	1:1	6000	32Nm	P=30bar	X					80	59	-	-	-
SAU0070416	Ø16x17	1:1	6000	32Nm		X	16	17		59.5		45	OKU0290009	CH_VTCROCE_M08	-
SAU0070422	Ø22x19	1:1	6000	32Nm		X	22	19		61.5		45	OKU0290009	CH_VTCROCE_M10	-

SAUTER
VDI 30
MODULO MOTORIZZATO ASSIALE VDI30 DIN 5480
Axial driven tool VDI30 DIN 5480
Axial angetriebenes Werkzeug VDI30 DIN 5480

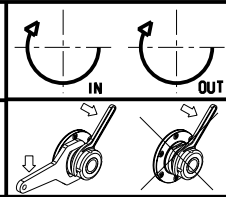

M.T. srl
Via Casino Albini 480
Tel. 0541/956034-957884
Fax 0541/956341
47842 S. GIOVANNI IN M. (RN)
e-mail: mtma@mtmarchetti.com
http://www.mtmarchetti.com

PRODUZIONE MODULI ROTANTI

PAGINA SAU017-2-00

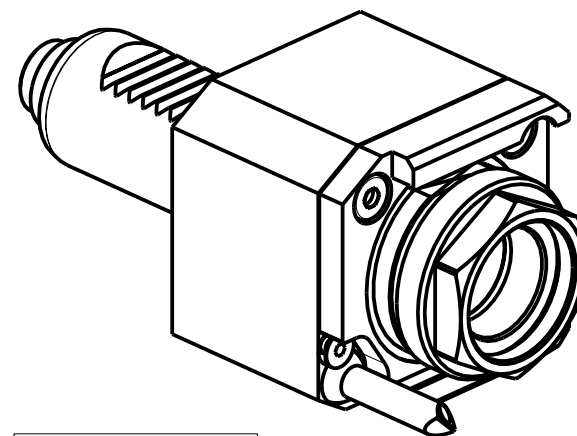
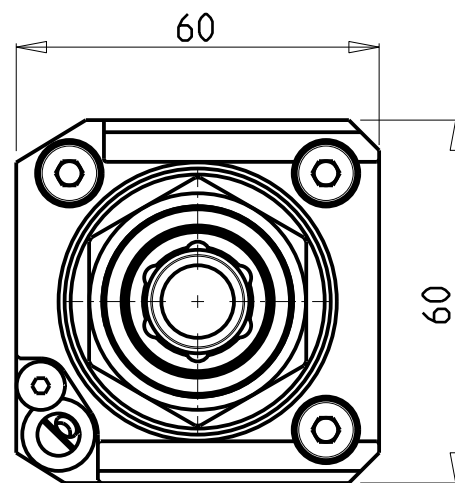
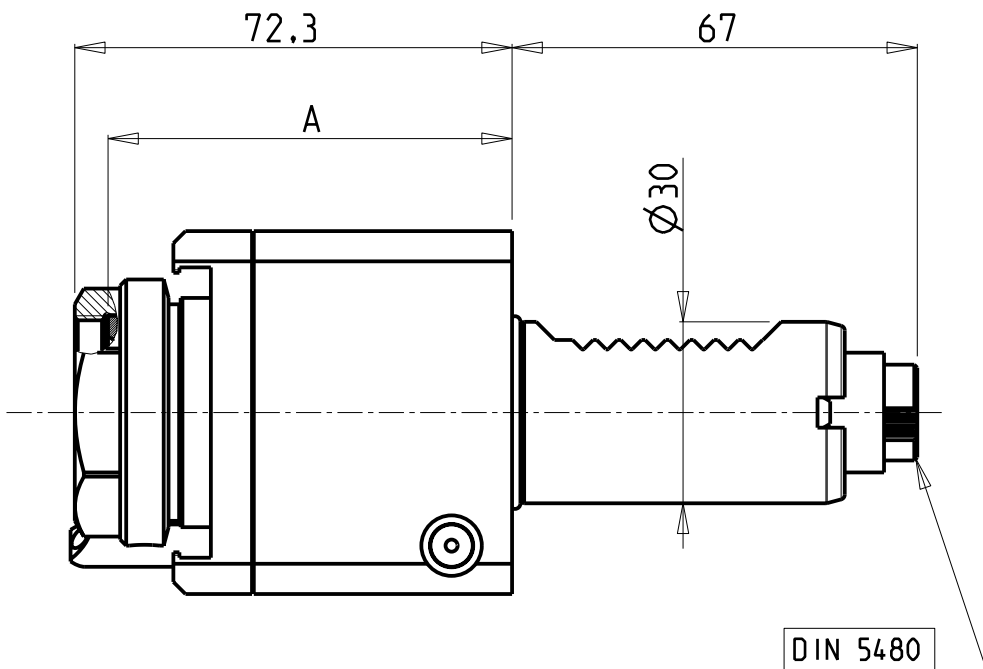

DIN 5480

- Chiave inclusa
- Key included
- Schlüssel inbegriffen

PER PORTAUTENSILI MODULARI MTSK-32 VEDI PAG. TBL300-1-32
 FOR MTSK-32 QUICK CHANGE TOOLHOLDERS CLAMPINGS SEE PAGE TBL300-1-32
 FUER MTSK-32 MODULARE WERKZEUGAUFNAHMEN SIEHE SEITE TBL300-1-32

Cod. MT	Mandrino Spindle Spindel	I	RPM	Coppia Max Max Torque Max Drehmoment	Lubrificazione int. Coolant through Innenkuehlung	Lubrificazione est. Ext. coolant Aussenkuehlung	A	CHIAVI NON INCLUSE Keys not included Schlüssel nicht einbegriffen	
SAU0610132	MTSK-32	1:1	6000	40Nm	-	X	66.8	CHUB36	OKU0290009 *
SAU0610232	MTSK-32	1:1	6000	40Nm	P=30bar	X	80.8	CHUB36	OKU0290009 *

SAUTER
VDI 30

MODULO MOTORIZZATO ASSIALE MTSK VDI30 DIN 5480
 Axial MTSK driven tool VDI30 DIN 5480
 Axial MTSK angetriebenes Werkzeug VDI30 DIN 5480

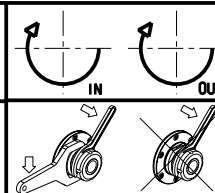

M.T. srl
 Via Casino Albini 480
 Tel. 0541/956034-957884
 Fax 0541/956341
 47842 S. GIOVANNI IN M. (RN)
 e-mail: mtma@mtmarchetti.com
 http://www.mtmarchetti.com

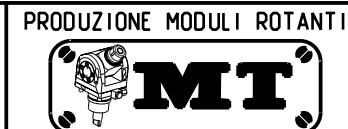

PAGINA SAU017-2-00-K

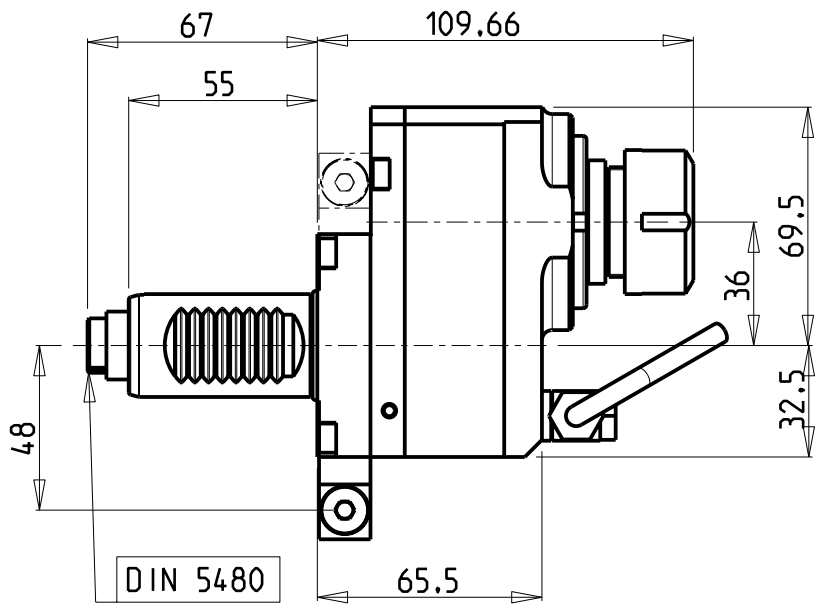

versione dx
right version
version rechts

versione sx
left version
version links

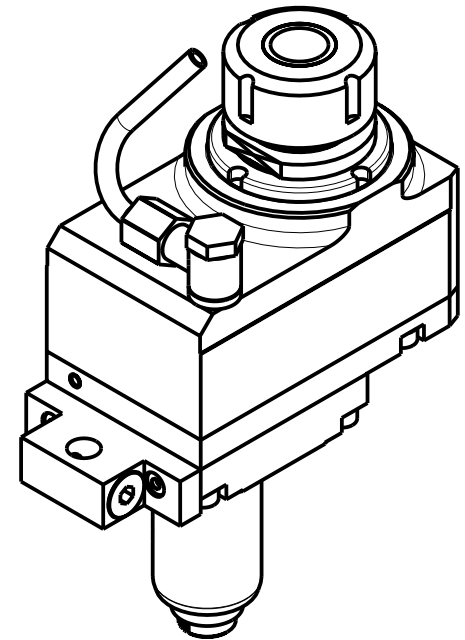
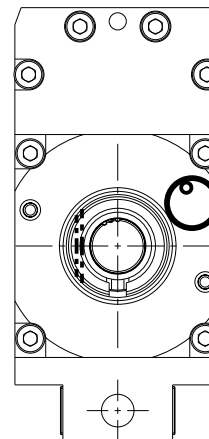
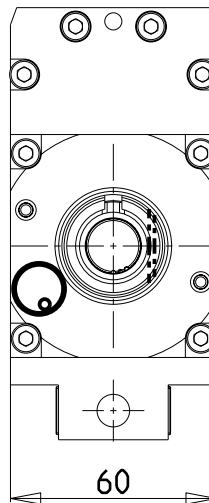

ATTENZIONE - ATTENTION - ACHTUNG

- Per lo smontaggio degli utensili utilizzare sempre la chiave di contrasto come indicato nel manuale d'uso.
- For disassembly of the tools use always the contrast key as mentioned in the user instructions.
- Fuer das Abmontieren der Werkzeuge immer den Gegenschlüssel benutzen wie in der Bedienungsanleitung erwaeht.

Cod. MT		Mandrino Spindle Spindel	I	RPM	Coppia Max Max Torque Max Drehmoment	Lubrificazione est. Ext. coolant Auslenkuehlung	CHIAVI NON INCLUSE Keys not included Schluesssel nicht einbegriffen	
versione dx right version version rechts	versione sx left version version links						CHUB36	CHSTER25
SAU0100125	SAU0101125	ER25	1:1	6000	30Nm	X	CHUB36	CHSTER25

SAUTER
VDI 30

MODULO MOTORIZZATO ASSIALE DISASSATO 36mm VDI30 DIN 5480
Axial driven tool re-directed by 36mm VDI30 DIN 5480
Axial angetriebenes Werkzeug achsversetzt um 36mm VDI30 DIN 5480

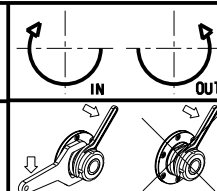

M.T. srl

Via Casino Albini 480
Tel. 0541/956034-957884
Fax 0541/956341

47842 S. GIOVANNI IN M. (RN)
e-mail: mtma@mtmarchetti.com
http://www.mtmarchetti.com

PRODUZIONE MODULI ROTANTI



PAGINA SAU017-2-05

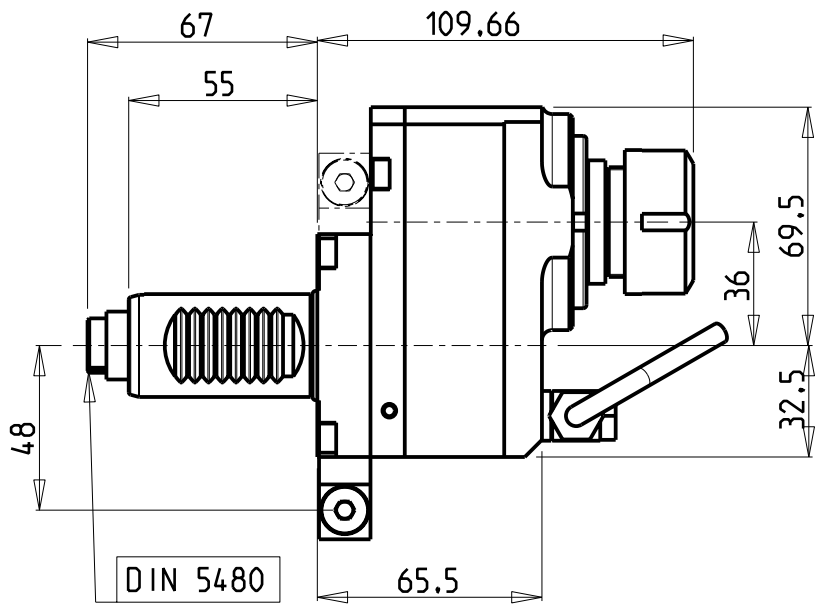

versione dx
right version
version rechts

versione sx
left version
version links

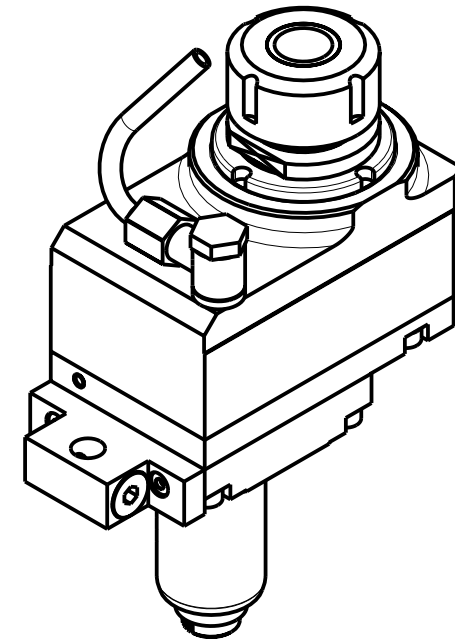
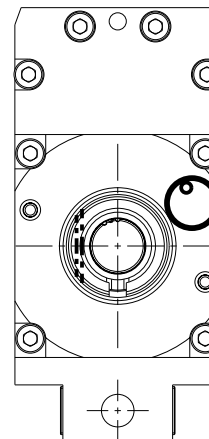
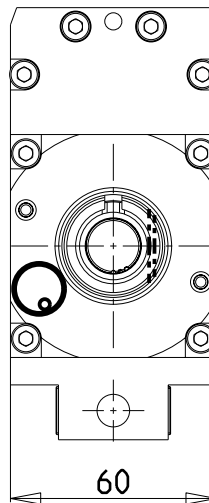

ATTENZIONE - ATTENTION - ACHTUNG

- Per lo smontaggio degli utensili utilizzare sempre la chiave di contrasto come indicato nel manuale d'uso.
- For disassembly of the tools use always the contrast key as mentioned in the user instructions.
- Fuer das Abmontieren der Werkzeuge immer den Gegenschlüssel benutzen wie in der Bedienungsanleitung erwahnt.

Cod. MT		Mandrino Spindle Spindel	I	RPM	Coppia Max Max Torque Max Drehmoment	Lubrificazione est. Ext. coolant Auslenkuehlung	CHIAVI NON INCLUSE Keys not included Schluesssel nicht einbegriffen	
versione dx right version version rechts	versione sx left version version links						CHUB36	CHSTER25
SAU0100325	SAU0101325	ER25	2:1	3000	45Nm	X	CHUB36	CHSTER25

SAUTER
VDI 30

MODULO MOTORIZZATO ASSIALE RIDOTTO I=2:1 DISASSATO 36mm VDI30 DIN 5480
Axial geared-down I=2:1 driven tool re-directed by 36mm VDI30 DIN 5480
Axial angetriebenes Werkzeug untersetzt I=2:1 achsversetzt um 36mm VDI30 DIN 5480

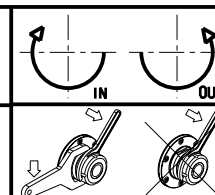

M.T. srl

Via Casino Albini 480
Tel. 0541/956034-957884
Fax 0541/956341

47842 S. GIOVANNI IN M. (RN)
e-mail: mtma@mtmarchetti.com
http://www.mtmarchetti.com

PRODUZIONE MODULI ROTANTI



PAGINA SAU017-2-30

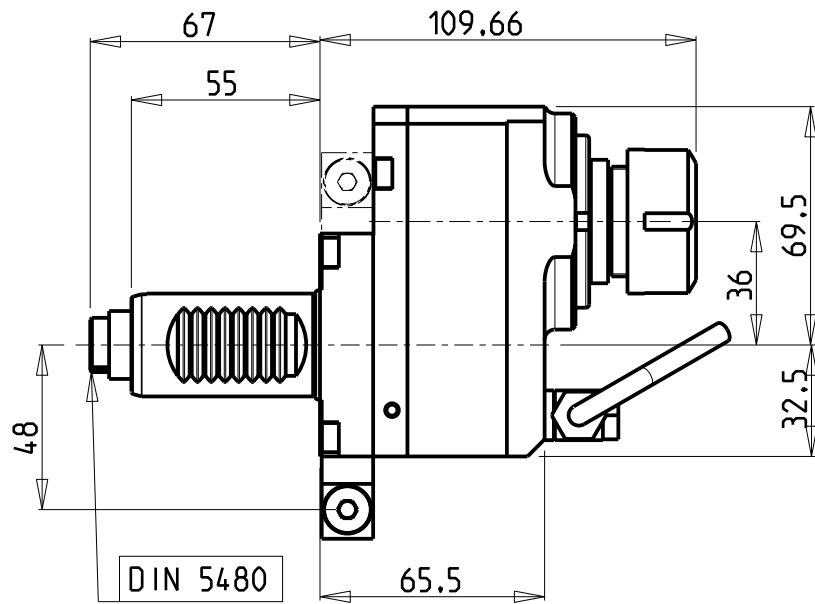

versione dx
right version
version rechts

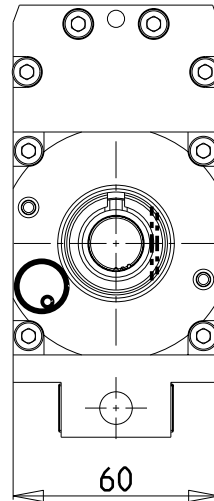

versione sx
left version
version links

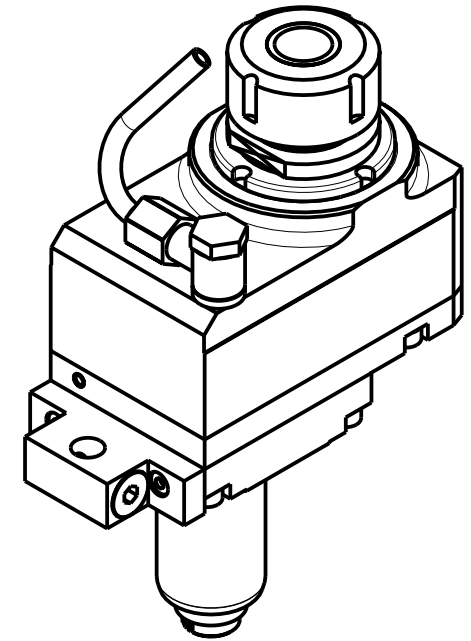
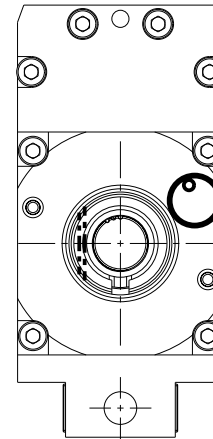

ATTENZIONE - ATTENTION - ACHTUNG

- Per lo smontaggio degli utensili utilizzare sempre la chiave di contrasto come indicato nel manuale d'uso.
- For disassembly of the tools use always the contrast key as mentioned in the user instructions.
- Fuer das Abmontieren der Werkzeuge immer den Gegenschlüssel benutzen wie in der Bedienungsanleitung erwahnt.

Cod. MT		Mandrino Spindle Spindel	i	RPM	Coppia Max Max Torque Max Drehmoment	Lubrificazione est. Ext. coolant Aussenkuehlung	CHIAVI NON INCLUSE Keys not included Schluesssel nicht einbegriffen	
versione dx right version version rechts	versione sx left version version links						CHUB36	CHSTER25
SAU0100225	SAU0101225	ER25	1:2	12000	20Nm	X	CHUB36	CHSTER25

SAUTER
VDI 30

MODULO MOTORIZZATO ASSIALE MOLTIPLICATO I=1:2 DISASSATO 36mm VDI30 DIN 5480
Axial geared-up I=1:2 driven tool re-directed by 36mm VDI30 DIN 5480
Axial angetriebenes Werkzeug uebersetzt I=1:2 achsversetzt um 36mm VDI30 DIN 5480

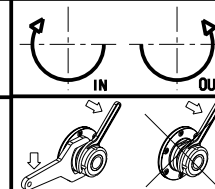

M.T. srl

Via Casino Albini 480
Tel. 0541/956034-957884
Fax 0541/956341

47842 S. GIOVANNI IN M. (RN)
e-mail: mtma@mtmarchetti.com
http://www.mtmarchetti.com

PRODUZIONE MODULI ROTANTI



PAGINA SAU017-2-60

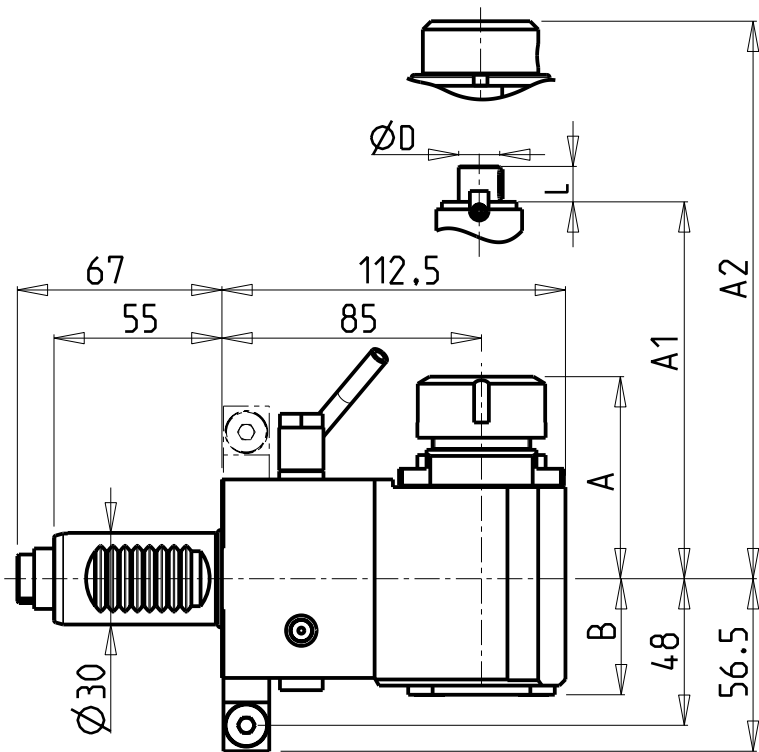

versione dx
right version
version rechts

versione sx
left version
version links

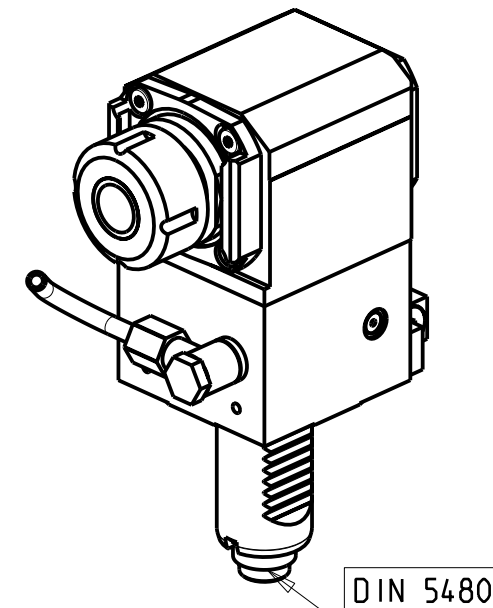
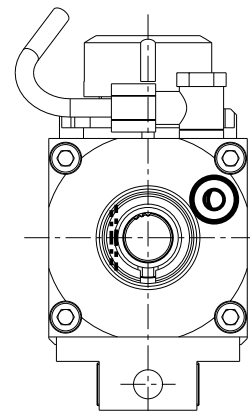
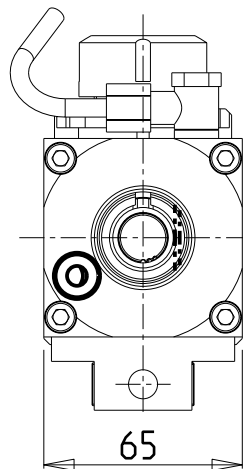

- Chiave inclusa
- Key included
- Schlüssel inbegriffen

Cod. MT		Mandrino Spindle Spindel	I	RPM	Coppia Max Max Torque Max Drehmoment	Lubrificazione int. Coolant through Innenkuehlung	Lubrificazione est. Ext. coolant Aussenkuehlung	ØD	L	A	A1	A2	B	CHIAVI NON INCLUDE Keys not included Schlüssel nicht inbegriffen	
versione dx right version version rechts	versione sx left version version links	ER25	1:1	6000	32Nm	-	X	-	-	66.2	-	-	38	OKU0290009	CHSTER25
SAU0080125	SAU0081125	ER25	1:1	6000	32Nm	P=70bar	X	-	-	66.2	-	-	48	OKU0290009	CHSTER25
SAU0080225	SAU0081225	WELDON16	1:1	6000	32Nm	-	X	-	-	-	-	54.5	38	-	-
SAU0080316	SAU0081316	Ø16x17	1:1	6000	32Nm	-	X	16	17	-	45	-	38	OKU0290009	CH_VTCROCE_M08
SAU0080416	SAU0081416	Ø22x19	1:1	6000	32Nm	-	X	22	19	-	47	-	38	OKU0290009	CH_VTCROCE_M10
SAU0080422	SAU0081422														

SAUTER
VDI 30

MODULO MOTORIZZATO RADIALE VDI30 DIN 5480 H=85mm
Radial driven tool VDI30 DIN 5480 H=85mm
Radial angetriebenes Werkzeug VDI30 DIN 5480 H=85mm

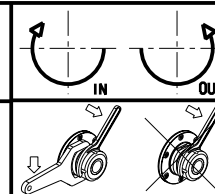

M.T. srl
Via Casino Albini 480
Tel. 0541/956034-957884
Fax 0541/956341
47842 S. GIOVANNI IN M. (RN)
e-mail: mtma@mtmarchetti.com
http://www.mtmarchetti.com

PRODUZIONE MODULI ROTANTI



PAGINA SAU018-2-00

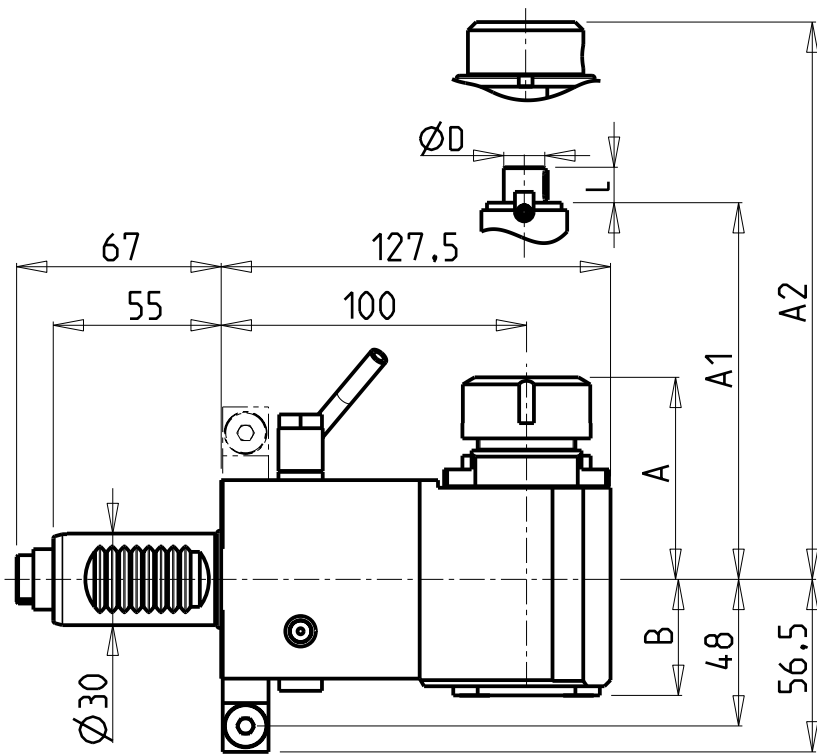

versione dx
right version
version rechts

versione sx
left version
version links

versione universale
universal version
universal version

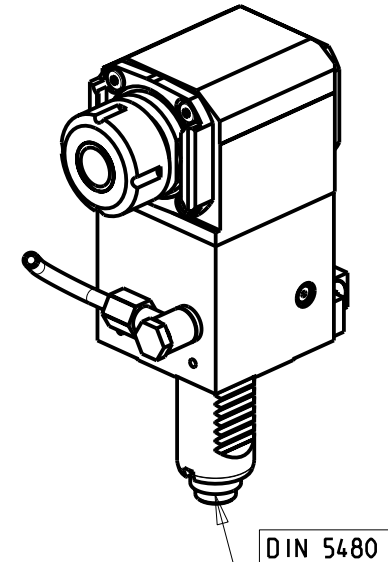
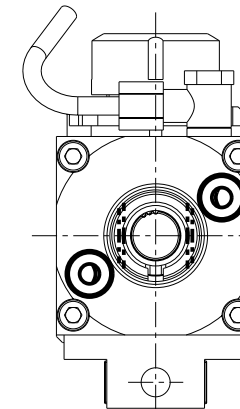
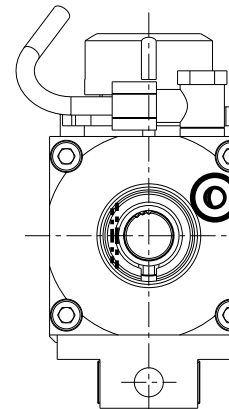
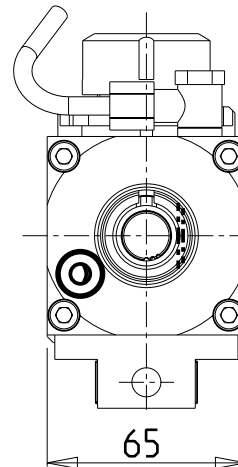

- Chiave inclusa
- Key included
- Schluessel inbegriffen

Cod. MT			Mandrino Spindle Spindel	I	RPM	Coppia Max Max Torque Max Drehmoment	Lubrificazione int. Coolant through Innenkuehlung	Lubrificazione est. Ext. coolant Aussenkuehlung	ØD	L	A	A1	A2	B	CHIAVI NON INCLUDE Keys not included Schluessel nicht einbegriffen	
versione dx right version version rechts	versione sx left version version links	versione universale universal version universal version														
SAU0160125	SAU0161125	SAU0162125	ER25	1:1	6000	32Nm	-	X	-	-	66.2	-	-	38	OKU0290009	CHSTER25
SAU0160225	SAU0161225	SAU0162225	ER25	1:1	6000	32Nm	P=70bar	X	-	-	66.2	-	-	48	OKU0290009	CHSTER25
SAU0160316	SAU0161316	SAU0162316	WELDON16	1:1	6000	32Nm	-	X	-	-	-	-	54.5	38	-	-
SAU0160416	SAU0161416	SAU0162416	Ø16x17	1:1	6000	32Nm	-	X	16	17	-	45	-	38	OKU0290009	CH_VTCROCE_M08
SAU0160422	SAU0161422	SAU0162422	Ø22x19	1:1	6000	32Nm	-	X	22	19	-	47	-	38	OKU0290009	CH_VTCROCE_M10

SAUTER
VDI 30

MODULO MOTORIZZATO RADIALE VDI30 DIN 5480 H=100mm
Radial driven tool VDI30 DIN 5480 H=100mm
Radial angetriebenes Werkzeug VDI30 DIN 5480 H=100mm

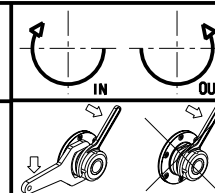

M.T. srl

Via Casino Albini 480
Tel. 0541/956034-957884
Fax 0541/956341
47842 S. GIOVANNI IN M. (RN)
e-mail: mtma@mtmarchetti.com
http://www.mtmarchetti.com

PRODUZIONE MODULI ROTANTI



PAGINA SAU018-2-10

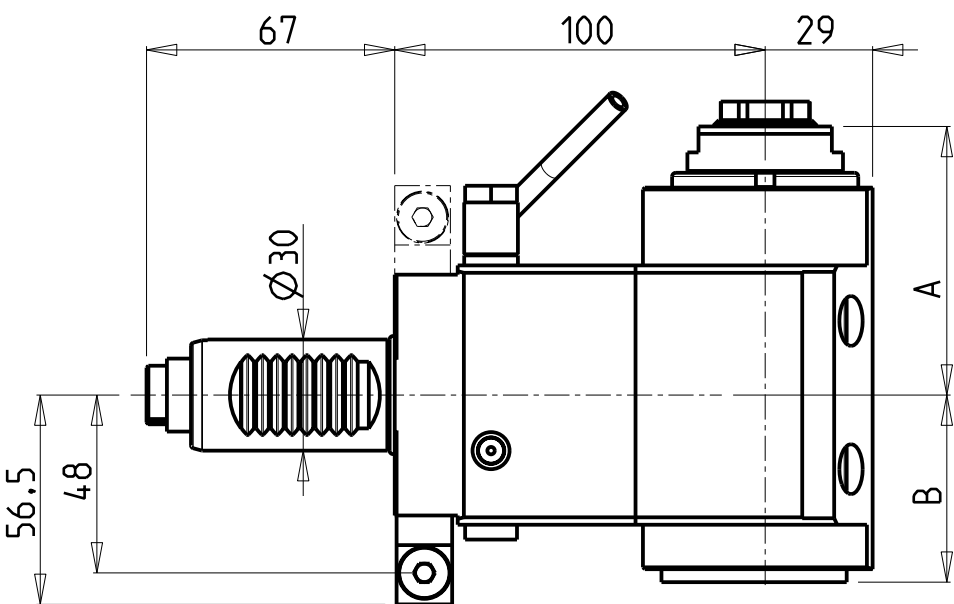

versione dx
right version
version rechts

versione sx
left version
version links

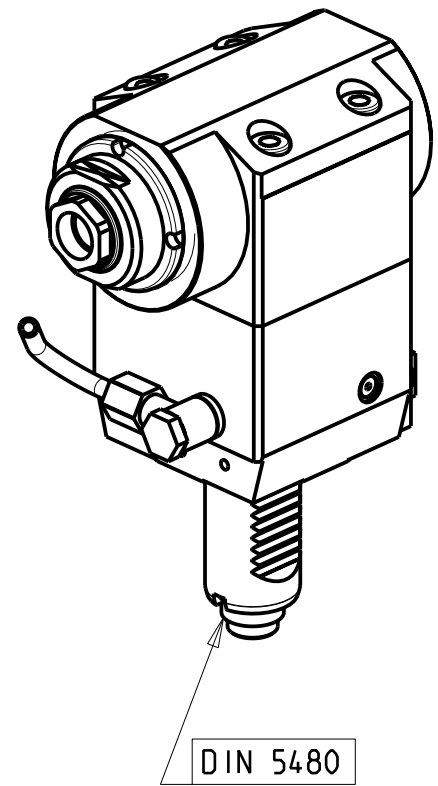
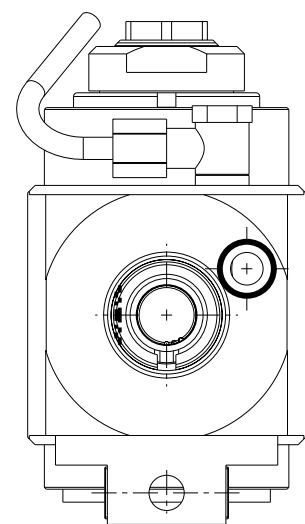
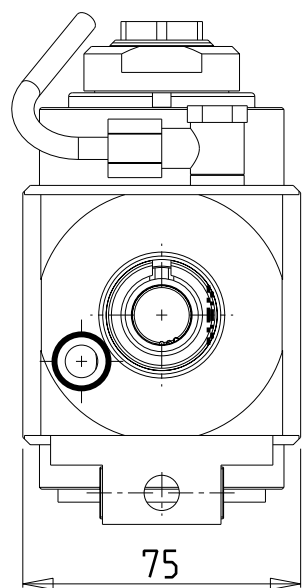

Cod. MT		Mandrino Spindle Spindel	I	RPM	Coppia Max Max Torque Max Drehmoment	Lubrificazione int. Coolant through Innenkuehlung	Lubrificazione est. Ext. coolant Aussenkuehlung	A	B	CHIAVI NON INCLUSE Keys not included Schlüssel nicht einbegriffen	
versione dx right version version rechts	versione sx left version version links										
SAU0340311	SAU0341311	ER11	1:2	12000	20Nm	-	X	83.6	50.5	CHUB36	CHUB17
SAU0340411	SAU0341411	ER11	1:2	12000	20Nm	P=70bar	X	83.6	58.5	CHUB36	CHUB17
SAU0340320	SAU0341320	ER20	1:2	12000	20Nm	-	X	92.2	50.5	CHUB36	CHSTER20
SAU0340420	SAU0341420	ER20	1:2	12000	20Nm	P=70bar	X	92.2	58.5	CHUB36	CHSTER20
SAU0340120	SAU0341120	ERA20	1:2	12000	20Nm	-	X	72.5	50.5	CHUB36	CHUB22
SAU0340220	SAU0341220	ERA20	1:2	12000	20Nm	P=70bar	X	72.5	58.5	CHUB36	CHUB22

NEW
NEW

SAUTER
VDI 30

MODULO MOTORIZZATO RADIALE MOLTIPLICATO I = 1:2 VDI30 DIN5480
Radial geared-up I=1:2 driven tool VDI30 DIN 5480
Radial angetriebenes Werkzeug uebersezt I=1:2 VDI30 DIN 5480

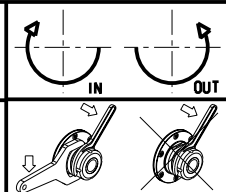

M.T. srl
Via Casino Albini 480
Tel. 0541/956034-957884
Fax 0541/956341
47842 S. GIOVANNI IN M. (RN)
e-mail: mtma@mtmarchetti.com
http://www.mtmarchetti.com

PRODUZIONE MODULI ROTANTI

PAGINA SAU018-2-13

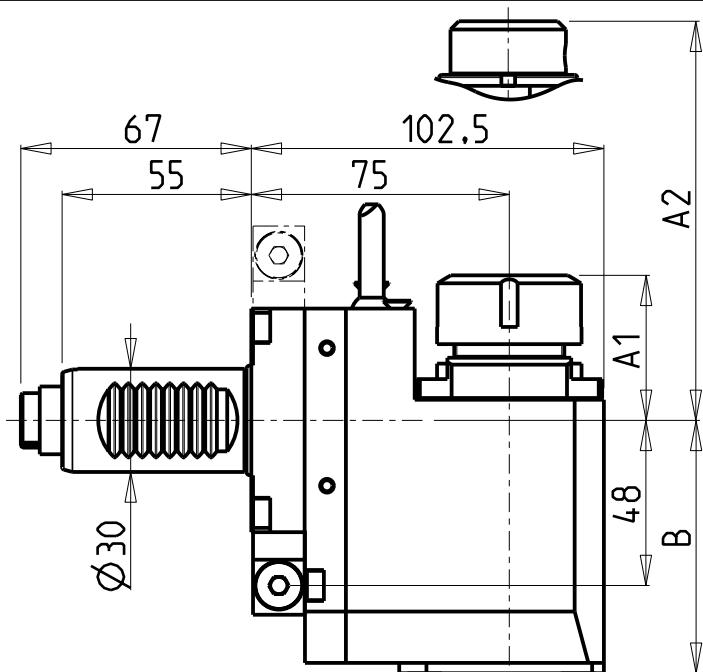

versione dx
right version
version rechts

versione sx
left version
version links

versione universale
universal version
universal version

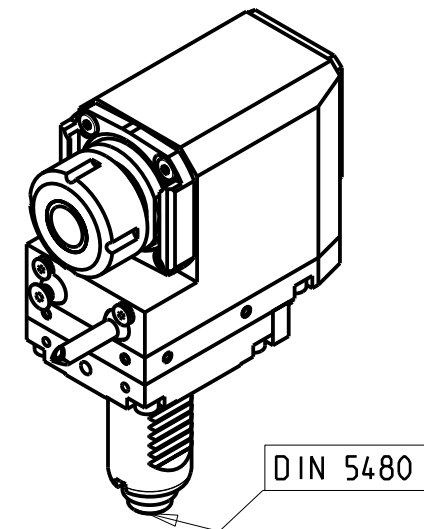
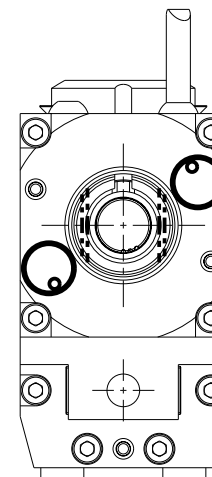
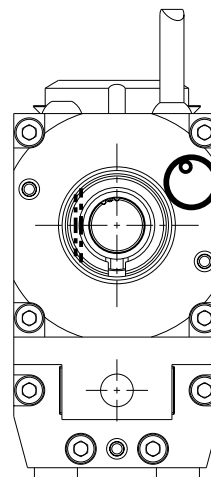
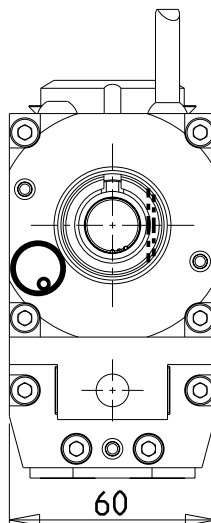

- Chiave inclusa
- Key included
- Schlüssel inbegriffen

Cod. MT			Mandrino Spindle Spindel	I	RPM	Coppia Max Max Torque Max Drehmoment	Lubrificazione int. Coolant through Innenkuehlung	Lubrificazione est. Ext. coolant Aussenkuehlung	A1	A2	B	CHIAVI NON INCLUSE Keys not included Schlüssel nicht einbegriffen		
versione dx right version version rechts	versione sx left version version links	versione universale universal version universal version												
SAU0090120	SAU0091120	SAU0092120	ER20	1:1	6000	32Nm	-	X	41.16	-	73.5	-	CHSTER20	OKU0290009
SAU0090320	SAU0091320	SAU0092320	ERA20	1:1	6000	32Nm	-	X	24.5	-	73.5	CHUB22	CHTAER20ZC	OKU0290009
SAU0090420	SAU0091420	SAU0092420	ERA20	1:1	6000	32Nm	P=70bar	X	24.5	-	83.5	CHUB22	CHTAER20ZC	OKU0290009
SAU0090125	SAU0091125	SAU0092125	ER25	1:1	6000	32Nm	-	X	42.16	-	73.5	-	CHSTER25	OKU0290009
SAU0090225	SAU0091225	SAU0092225	ER25	1:1	6000	32Nm	P=70bar	X	42.16	-	83.5	-	CHSTER25	OKU0290009
SAU0090325	SAU0091325	SAU0092325	ERA25	1:1	6000	32Nm	-	X	28.5	-	73.5	CHUB27	CHTAER25ZC	OKU0290009
SAU0090425	SAU0091425	SAU0092425	ERA25	1:1	6000	32Nm	P=70bar	X	28.5	-	83.5	CHUB27	CHTAER25ZC	OKU0290009
SAU0090516	SAU0091516	SAU0092516	WELDON16	1:1	6000	32Nm	-	X	-	27.5	73.5	-	-	-

SAUTER
VDI 30

MODULO MOTORIZZATO RADIALE ARRETRATO VDI30 DIN 5480 H=75mm
Radial rear-set driven tool VDI30 DIN 5480 H=75mm
Radial angetriebenes Werkzeug zurueckversetzt VDI30 DIN 5480 H=75mm

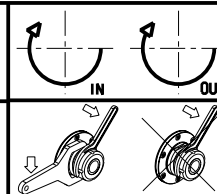

M.T. srl

Via Casino Albini 480
Tel. 0541/956034-957884
Fax 0541/956341

47842 S. GIOVANNI IN M. (RN)
e-mail: mtma@mtmarchetti.com
http://www.mtmarchetti.com

PRODUZIONE MODULI ROTANTI



PAGINA SAU018-2-60

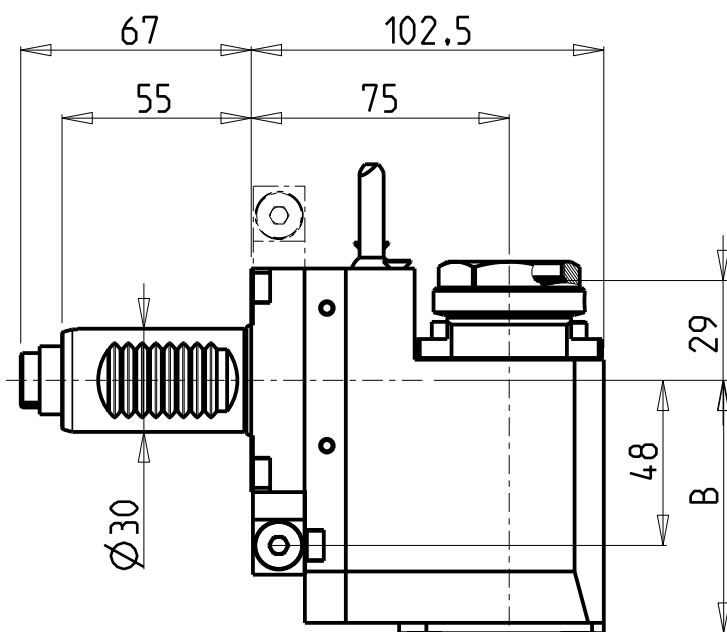

versione dx
right version
version rechts

versione sx
left version
version links

versione universale
universal version
universal version

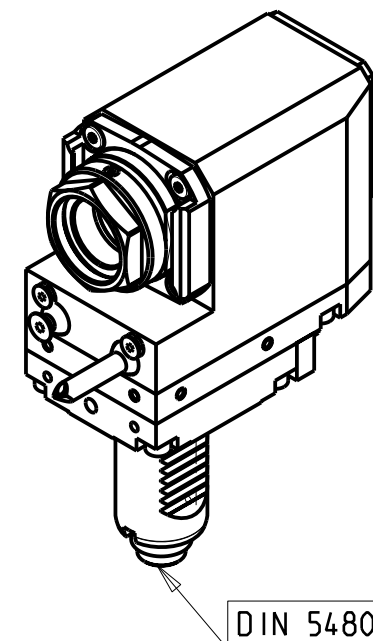
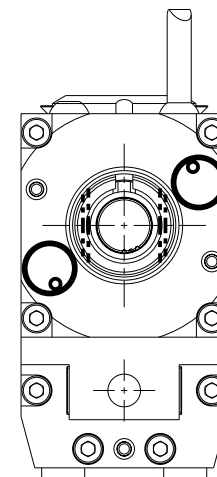
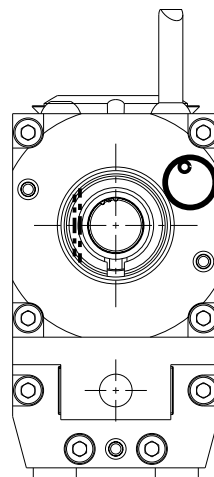
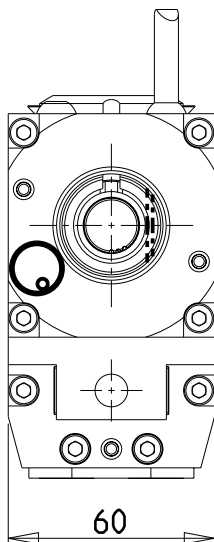

DIN 5480

PER PORTAUTENSILI MODULARI MTSK-32 VEDI PAG. TBL300-1-32
FOR MTSK-32 QUICK CHANGE TOOLHOLDERS CLAMPINGS SEE PAGE TBL300-1-32
FUER MTSK-32 MODULARE WERKZEUGAUFNAHMEN SIEHE SEITE TBL300-1-32

- Chiave inclusa
- Key included
- Schlüssel inbegriffen

Cod. MT			Mandrino Spindle Spindel	I	RPM	Coppia Max Max Torque Max Drehmoment	Lubrificazione int. Coolant through Innenkuehlung	Lubrificazione est. Ext. coolant Aussenkuehlung	B	CHIAVI NON INCLUDE Keys not included Schlüssel nicht einbegriffen	
versione dx right version version rechts	versione sx left version version links	versione universale universal version universal version								CHUB36	OKU0290009
SAU0640132	SAU0641132	SAU0642132	MTSK-32	1:1	6000	32Nm	-	X	73.5	CHUB36	OKU0290009
SAU0640232	SAU0641232	SAU0642232	MTSK-32	1:1	6000	32Nm	P=70bar	X	83.5	CHUB36	OKU0290009

SAUTER
VDI 30

MODULO MOTORIZZATO RADIALE ARRETRATO MTSK VDI30 DIN 5480 H=75mm
Radial MTSK rear-set driven tool VDI30 DIN 5480 H=75mm
Radial MTSK angetriebenes Werkzeug zurueckversetzt VDI30 DIN 5480 H=75mm

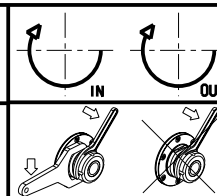

M.T. srl
Via Casino Albini 480
Tel. 0541/956034-957884
Fax 0541/956341
47842 S. GIOVANNI IN M. (RN)
e-mail: mtma@mtmarchetti.com
http://www.mtmarchetti.com

PRODUZIONE MODULI ROTANTI



PAGINA SAU018-2-60-K

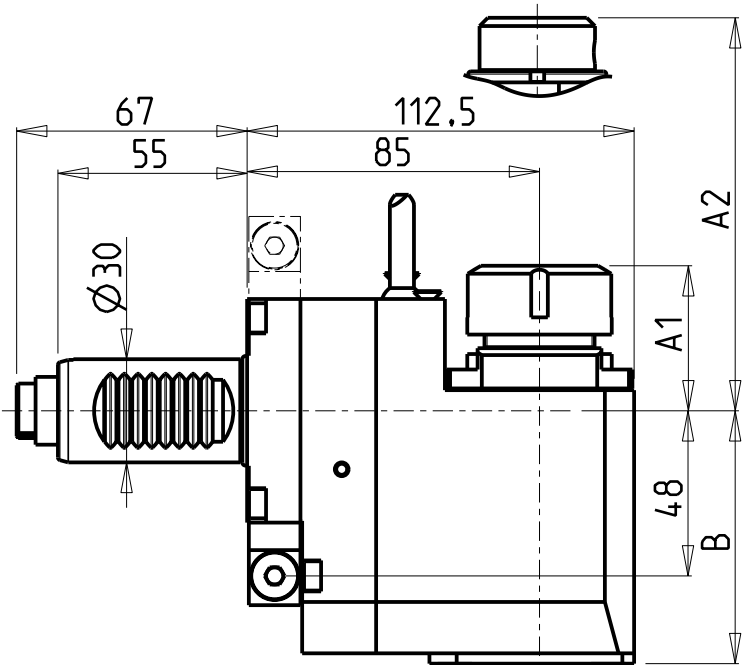

versione dx
right version
version rechts

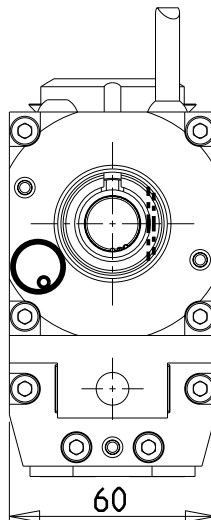

versione sx
left version
version links

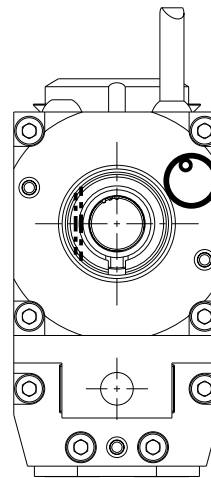

versione universale
universal version
universal version

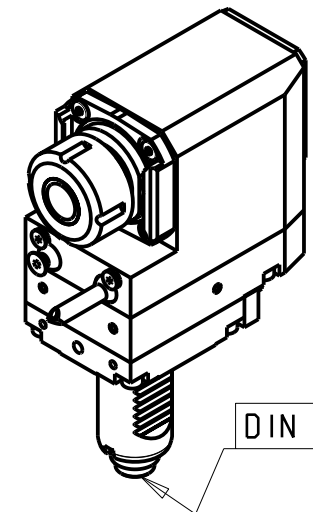
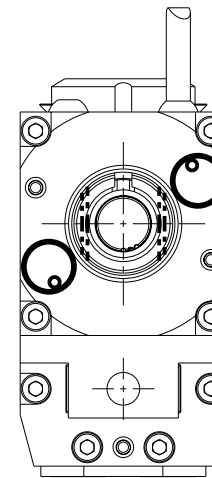

- Chiave inclusa
- Key included
- Schlüssel inbegriffen

Cod. MT			Mandrino Spindle Spindel	I	RPM	Coppia Max Max Torque Max Drehmoment	Lubrificazione int. Coolant through Innenkuehlung	Lubrificazione est. Ext. coolant Aussenkuehlung	A1	A2	B	CHIAVI NON INCLUSE Keys not included Schlüssel nicht einbegriffen			
versione dx right version version rechts	versione sx left version version links	versione universale universal version universal version													
SAU0130120	SAU0131120	SAU0132120	ER20	1:1	6000	32Nm	-	X	41.16	-	73.5	-	CHSTER20	OKU0290009	•
SAU0130320	SAU0131320	SAU0132320	ERA20	1:1	6000	32Nm	-	X	24.5	-	73.5	CHUB22	CHTAER20ZC	•	OKU0290009
SAU0130420	SAU0131420	SAU0132420	ERA20	1:1	6000	32Nm	P=70bar	X	24.5	-	83.5	CHUB22	CHTAER20ZC	•	OKU0290009
SAU0130125	SAU0131125	SAU0132125	ER25	1:1	6000	32Nm	-	X	42.16	-	73.5	-	CHSTER25	OKU0290009	•
SAU0130225	SAU0131225	SAU0132225	ER25	1:1	6000	32Nm	P=70bar	X	42.16	-	83.5	-	CHSTER25	OKU0290009	•
SAU0130325	SAU0131325	SAU0132325	ERA25	1:1	6000	32Nm	-	X	28.5	-	73.5	CHUB27	CHTAER25ZC	•	OKU0290009
SAU0130425	SAU0131425	SAU0132425	ERA25	1:1	6000	32Nm	P=70bar	X	28.5	-	83.5	CHUB27	CHTAER25ZC	•	OKU0290009
SAU0130516	SAU0131516	SAU0132516	WELDON16	1:1	6000	32Nm	-	X	-	27.5	73.5	-	-	-	-

SAUTER
VDI 30

MODULO MOTORIZZATO RADIALE ARRETRATO VDI30 DIN 5480 H=85mm
Radial rear-set driven tool VDI30 DIN 5480 H=85mm
Radial angetriebenes Werkzeug zurueckversetzt VDI30 DIN 5480 H=85mm

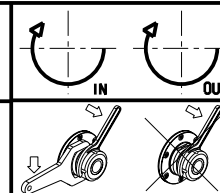

M.T. srl

Via Casino Albini 480
Tel. 0541/956034-957884
Fax 0541/956341
47842 S. GIOVANNI IN M. (RN)
e-mail: mtma@mtmarchetti.com
http://www.mtmarchetti.com

PRODUZIONE MODULI ROTANTI



PAGINA SAU018-2-70

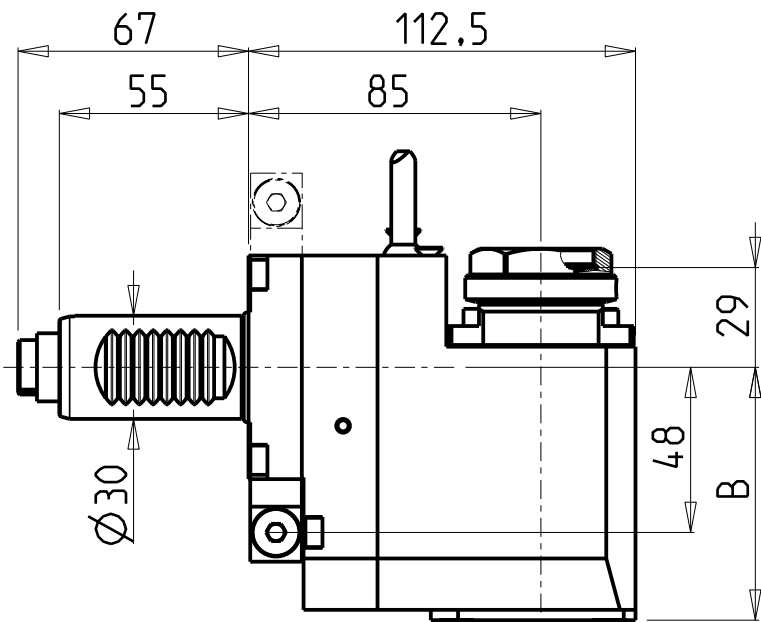

versione dx
right version
version rechts

versione sx
left version
version links

versione universale
universal version
universal version

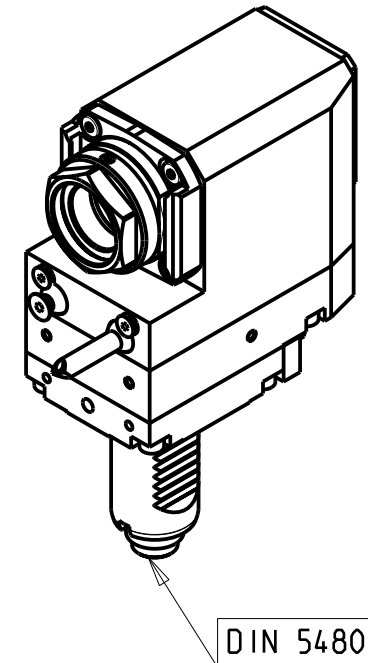
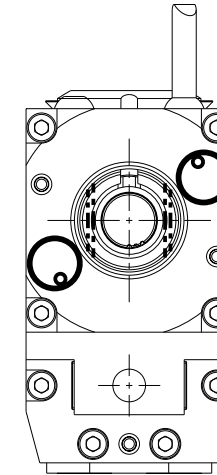
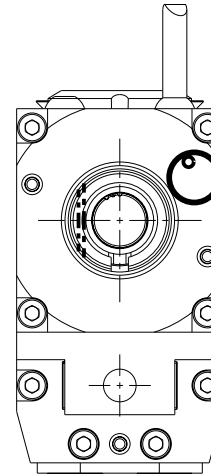
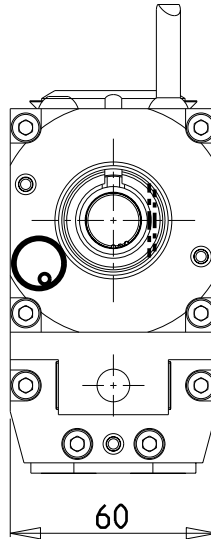

DIN 5480

PER PORTAUTENSILI MODULARI MTSK-32 VEDI PAG. TBL300-1-32
FOR MTSK-32 QUICK CHANGE TOOLHOLDERS CLAMPINGS SEE PAGE TBL300-1-32
FUER MTSK-32 MODULARE WERKZEUGAUFNAHMEN SIEHE SEITE TBL300-1-32

- Chiave inclusa
- Key included
- Schluessel inbegriffen

Cod. MT			Mandrino Spindle Spindel	I	RPM	Coppia Max Max Torque Max Drehmoment	Lubrificazione int. Coolant through Innenkuehlung	Lubrificazione est. Ext. coolant Aussenkuehlung	B	CHIAVI NON INCLUDE Keys not included Schluessel nicht einbegriffen	
versione dx right version version rechts	versione sx left version version links	versione universale universal version universal version								C HUB36	OKU0290009 •
SAU0650132	SAU0651132	SAU0652132	MTSK-32	1:1	6000	32Nm	-	X	73.5	C HUB36	OKU0290009 •
SAU0650232	SAU0651232	SAU0652232	MTSK-32	1:1	6000	32Nm	P=70bar	X	83.5	C HUB36	OKU0290009 •

SAUTER
VDI 30

MODULO MOTORIZZATO RADIALE ARRETRATO MTSK VDI30 DIN 5480 H=85mm
Radial MTSK rear-set driven tool VDI30 DIN 5480 H=85mm
Radial MTSK angetriebenes Werkzeug zurueckversetzt VDI30 DIN 5480 H=85mm

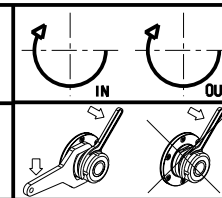

M.T. srl
Via Casino Albini 480
Tel. 0541/956034-957884
Fax 0541/956341
47842 S. GIOVANNI IN M. (RN)
e-mail: mtma@mtmarchetti.com
http://www.mtmarchetti.com

PRODUZIONE MODULI ROTANTI



PAGINA SAU018-2-70-K

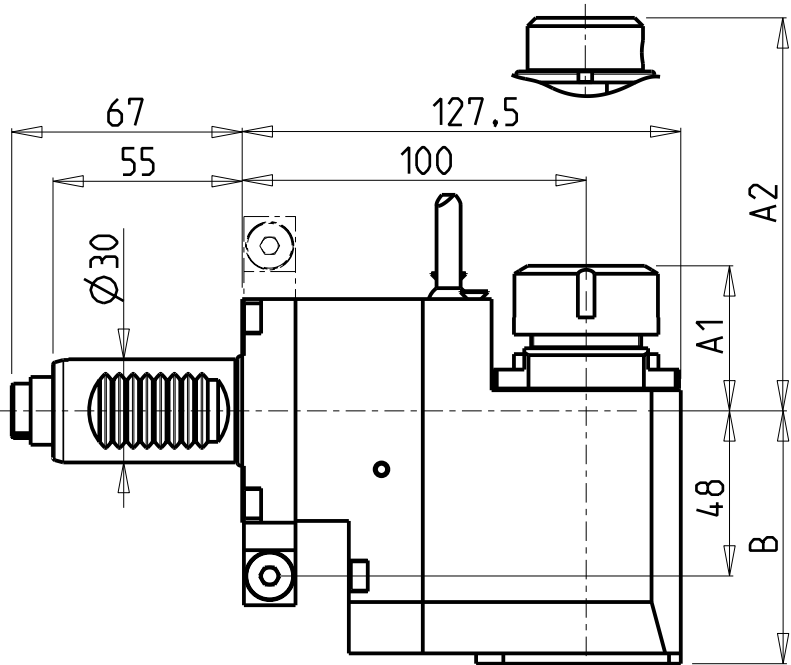

versione dx
right version
version rechts

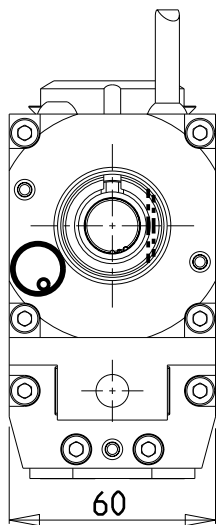

versione sx
left version
version links

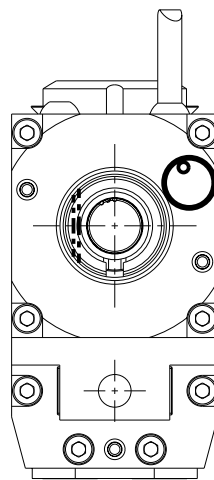

versione universale
universal version
universal version

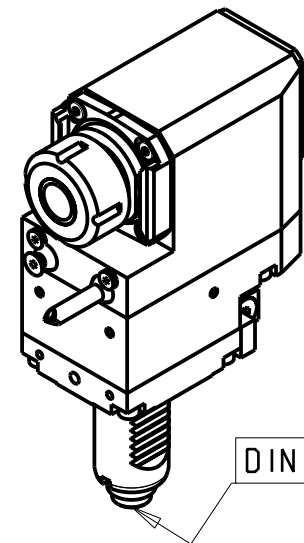
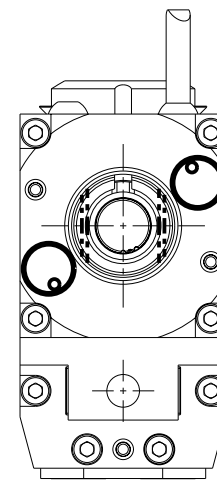

- Chiave inclusa
- Key included
- Schlüssel inbegriffen

Cod. MT			Mandrino Spindle Spindel	I	RPM	Coppia Max Max Torque Max Drehmoment	Lubrificazione int. Coolant through Innenkuehlung	Lubrificazione est. Ext. coolant Aussenkuehlung	A1	A2	B	CHIAVI NON INCLUSE Keys not included Schlüssel nicht einbegriffen				
versione dx right version version rechts	versione sx left version version links	versione universale universal version universal version														
SAU0140120	SAU0141120	SAU0142120	ER20	1:1	6000	32Nm	-	X	41.16	-	73.5	-	CHSTER20	OKU0290009	•	
SAU0140320	SAU0141320	SAU0142320	ERA20	1:1	6000	32Nm	-	X	24.5	-	73.5	CHUB22	CHTAER20ZC	•	OKU0290009	•
SAU0140420	SAU0141420	SAU0142420	ERA20	1:1	6000	32Nm	P=70bar	X	24.5	-	83.5	CHUB22	CHTAER20ZC	•	OKU0290009	•
SAU0140125	SAU0141125	SAU0142125	ER25	1:1	6000	32Nm	-	X	42.16	-	73.5	-	CHSTER25	OKU0290009	•	
SAU0140225	SAU0141225	SAU0142225	ER25	1:1	6000	32Nm	P=70bar	X	42.16	-	83.5	-	CHSTER25	OKU0290009	•	
SAU0140325	SAU0141325	SAU0142325	ERA25	1:1	6000	32Nm	-	X	28.5	-	73.5	CHUB27	CHTAER25ZC	•	OKU0290009	•
SAU0140425	SAU0141425	SAU0142425	ERA25	1:1	6000	32Nm	P=70bar	X	28.5	-	83.5	CHUB27	CHTAER25ZC	•	OKU0290009	•
SAU0140516	SAU0141516	SAU0142516	WELDON16	1:1	6000	32Nm	-	X	-	27.5	73.5	-	-	-	-	

SAUTER
VDI 30

MODULO MOTORIZZATO RADIALE ARRETRATO VDI30 DIN 5480 H=100mm
Radial rear-set driven tool VDI30 DIN 5480 H=100mm
Radial angetriebenes Werkzeug zurueckversetzt VDI30 DIN 5480 H=100mm

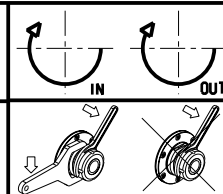

M.T. srl

Via Casino Albini 480
Tel. 0541/956034-957884
Fax 0541/956341

47842 S. GIOVANNI IN M. (RN)
e-mail: mtma@mtmarchetti.com
http://www.mtmarchetti.com

PRODUZIONE MODULI ROTANTI



PAGINA SAU018-2-80

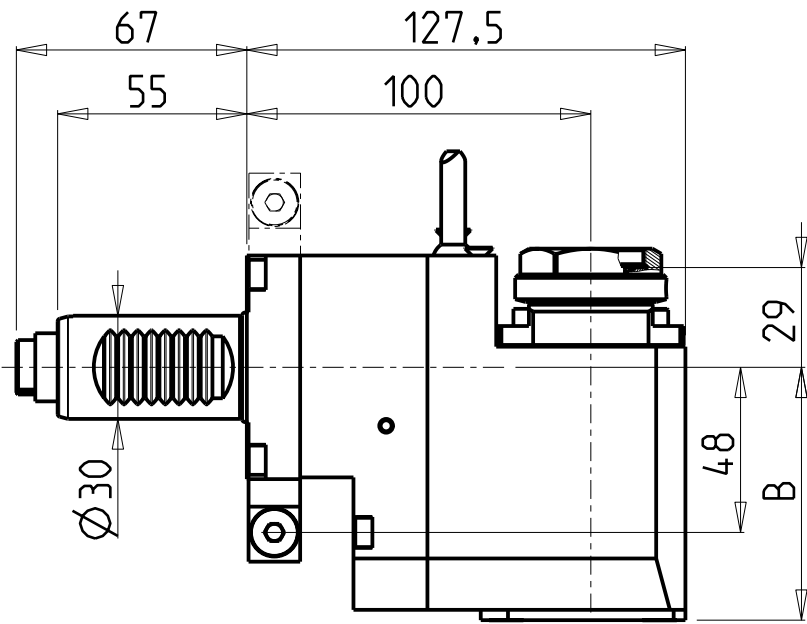

versione dx
right version
version rechts

versione sx
left version
version links

versione universale
universal version
universal version

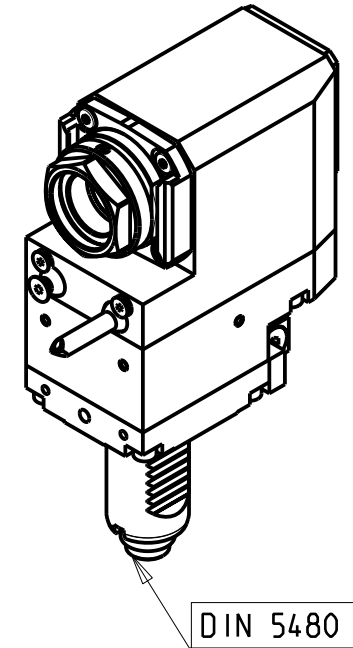
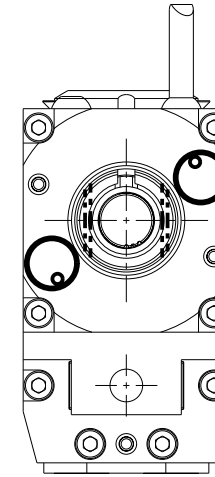
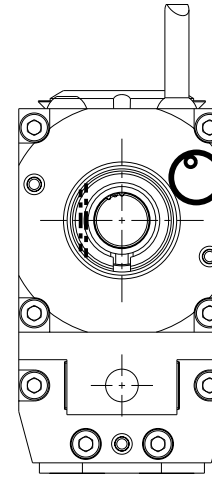
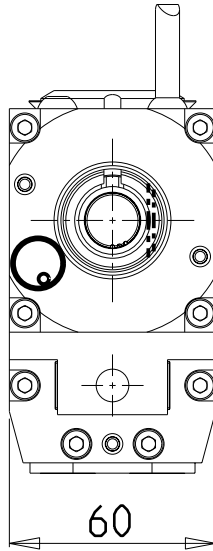

DIN 5480

PER PORTAUTENSILI MODULARI MTSK-32 VEDI PAG. TBL300-1-32
FOR MTSK-32 QUICK CHANGE TOOLHOLDERS CLAMPINGS SEE PAGE TBL300-1-32
FUER MTSK-32 MODULARE WERKZEUGAUFNAHMEN SIEHE SEITE TBL300-1-32

- Chiave inclusa
- Key included
- Schlüssel inbegriffen

Cod. MT			Mandrino Spindle Spindel	I	RPM	Coppia Max Max Torque Max Drehmoment	Lubrificazione int. Coolant through Innenkuehlung	Lubrificazione est. Ext. coolant Aussenkuehlung	B	CHIAVI NON INCLUDE Keys not included Schlüssel nicht einbegriffen	
versione dx right version version rechts	versione sx left version version links	versione universale universal version universal version								CHUB36	OKU0290009
SAU0660132	SAU0661132	SAU0662132	MTSK-32	1:1	6000	32Nm	-	X	73.5	CHUB36	OKU0290009
SAU0660232	SAU0661232	SAU0662232	MTSK-32	1:1	6000	32Nm	P=70bar	X	83.5	CHUB36	OKU0290009

SAUTER
VDI 30

MODULO MOTORIZZATO RADIALE ARRETRATO MTSK VDI30 DIN 5480 H=100mm
Radial MTSK rear-set driven tool VDI30 DIN 5480 H=100mm
Radial MTSK angetriebenes Werkzeug zurueckversetzt VDI30 DIN 5480 H=100mm

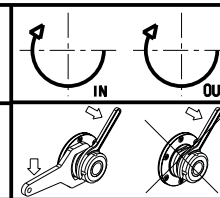

M.T. srl
Via Casino Albini 480
Tel. 0541/956034-957884
Fax 0541/956341
47842 S. GIOVANNI IN M. (RN)
e-mail: mtma@mtmarchetti.com
http://www.mtmarchetti.com

PRODUZIONE MODULI ROTANTI



PAGINA SAU018-2-80-K

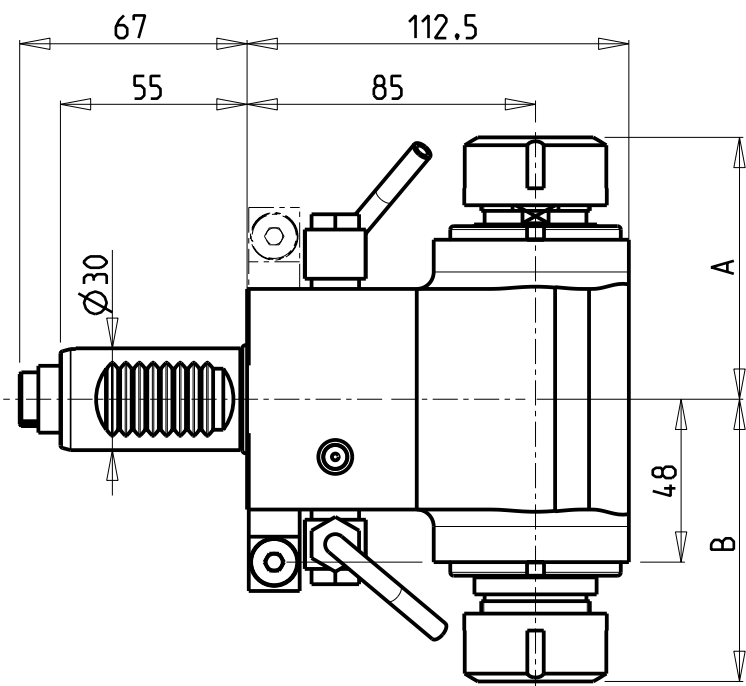

versione dx
right version
version rechts

versione sx
left version
version links

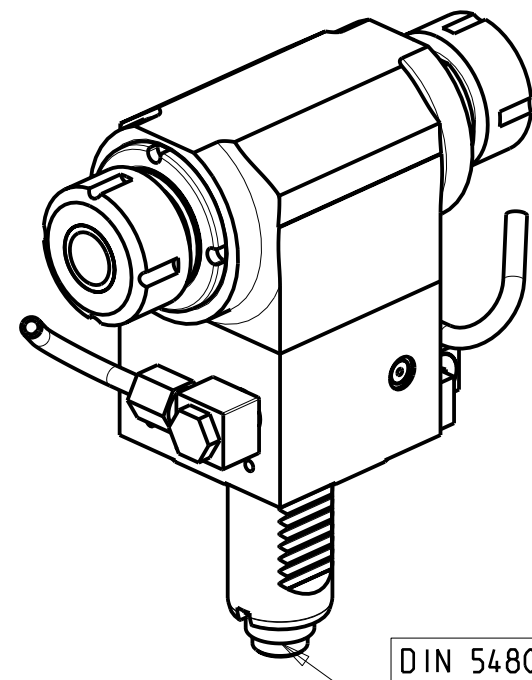
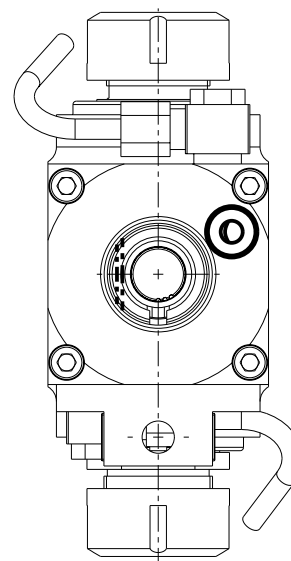
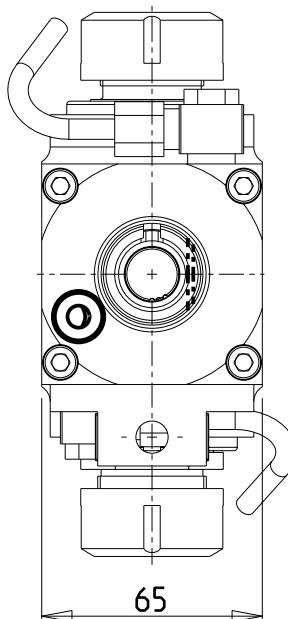

DIN 5480

ATTENZIONE - ATTENTION - ACHTUNG

- Per lo smontaggio degli utensili utilizzare sempre la chiave di contrasto come indicato nel manuale d'uso.
- For disassembly of the tools use always the contrast key as mentioned in the user instructions.
- Fuer das Abmontieren der Werkzeuge immer den Gegenschlüssel benutzen wie in der Bedienungsanleitung erwaeht.

Cod. MT		Mandrino Spindle Spindel	I	RPM	Coppia Max Max Torque Max Drehmoment	Lubrificazione est. Ext. coolant Aussenkuehlung	A	B	CHIAVI NON INCLUDE Keys not included Schluesel nicht einbegriffen		
versione dx right version version rechts	versione sx left version version links										
SAU0110220	SAU0111220	ER20-ER20	1:1	6000	32Nm	X	81.2	82.2	-	CHUB38	CHSTER20
SAU0110225	SAU0111225	ER25-ER25	1:1	6000	32Nm	X	77.2	83.2	CHUB29	CHUB36	CHSTER25

SAUTER
VDI 30

MODULO MOTORIZZATO RADIALE BISPORGENTE VDI30 DIN 5480 H=85mm
Radial opposite face twin driven tool VDI30 DIN 5480 H=85mm
Radial angetriebenes Werkzeug halb vorspringend VDI30 DIN 5480 H=85mm

M.T. srl

Via Casino Albini 480
Tel. 0541/956034-957884
Fax 0541/956341
47842 S. GIOVANNI IN M. (RN)
e-mail: mtma@mtmarchetti.com
http://www.mtmarchetti.com

PRODUZIONE MODULI ROTANTI



PAGINA SAU019-2-00

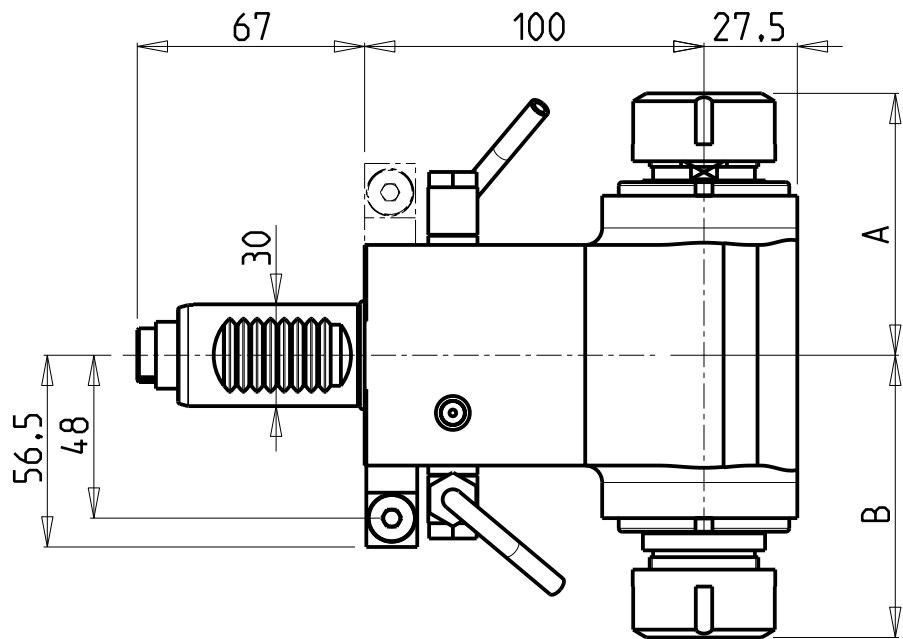

versione dx
right version
version rechts

versione sx
left version
version links

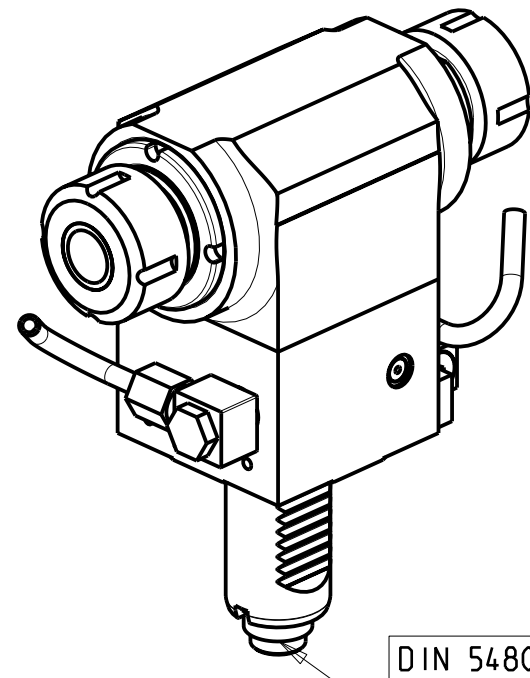
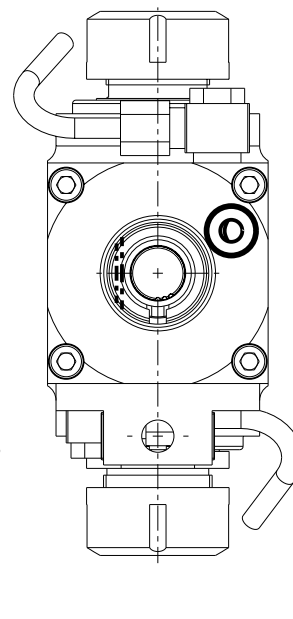
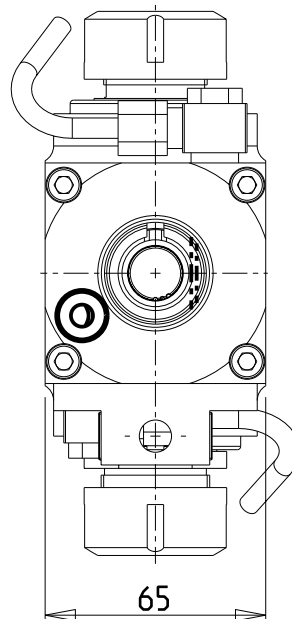

DIN 5480

ATTENZIONE - ATTENTION - ACHTUNG

- Per lo smontaggio degli utensili utilizzare sempre la chiave di contrasto come indicato nel manuale d'uso.
- For disassembly of the tools use always the contrast key as mentioned in the user instructions.
- Fuer das Abmontieren der Werkzeuge immer den Gegenschlüssel benutzen wie in der Bedienungsanleitung erwaeht.

Cod. MT		Mandrino Spindle Spindel	I	RPM	Coppia Max Max Torque Max Drehmoment	Lubrificazione est. Ext. coolant Ausseenkuehlung	A	B	CHIAVI NON INCLUDE Keys not included Schlüssel nicht einbegriffen		
versione dx right version version rechts	versione sx left version version links										
SAU0360220	SAU0361220	ER20-ER20	1:1	6000	32Nm	X	81.2	82.2	-	CHUB38	CHSTER20
SAU0360225	SAU0361225	ER25-ER25	1:1	6000	32Nm	X	77.2	83.2	CHUB29	CHUB36	CHSTER25

SAUTER
VDI 30

MODULO MOTORIZZATO RADIALE BISPORGENTE VDI30 DIN 5480 H=100mm
Radial opposite face twin driven tool VDI30 DIN 5480 H=100mm
Radial angetriebenes Werkzeug halb vorspringend VDI30 DIN 5480 H=100mm

M.T. srl

Via Casino Albini 480
Tel. 0541/956034-957884
Fax 0541/956341
47842 S. GIOVANNI IN M. (RN)
e-mail: mtma@mtmarchetti.com
http://www.mtmarchetti.com

PRODUZIONE MODULI ROTANTI



PAGINA SAU019-2-10

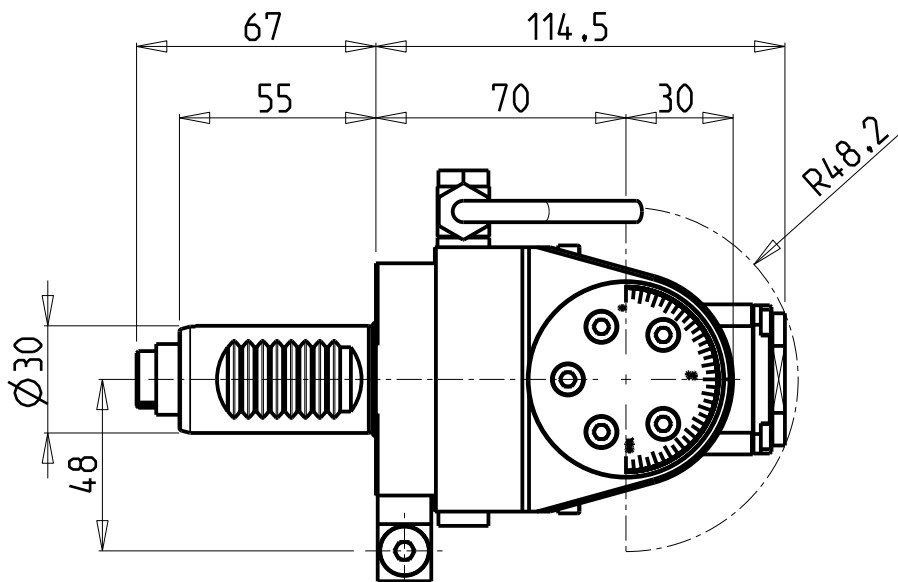

versione dx
right version
version rechts

versione sx
left version
version links

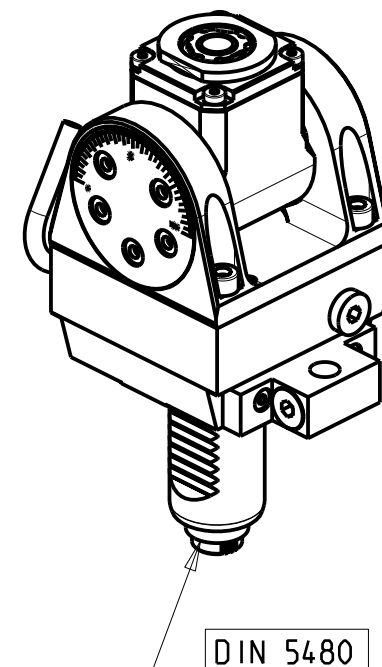
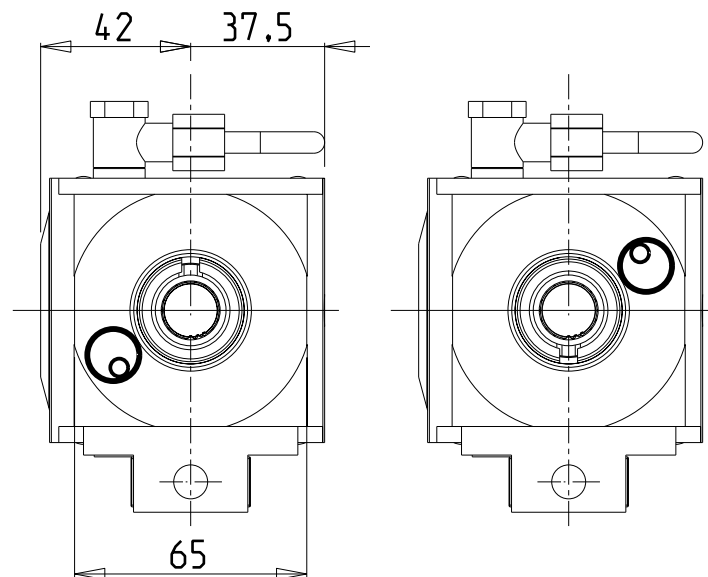

ATTENZIONE - ATTENTION - ACHTUNG

- Per lo smontaggio degli utensili utilizzare sempre la chiave di contrasto come indicato nel manuale d'uso.
- For disassembly of the tools use always the contrast key as mentioned in the user instructions.
- Fuer das Abmontieren der Werkzeuge immer den Gegenschlüssel benutzen wie in der Bedienungsanleitung erwaeht.

Cod. MT		Mandrino Spindle Spindel	I	RPM	Coppia Max Max Torque Max Drehmoment	Lubrificazione est. Ext. coolant Aussenkuehlung	CHIAVI INCLUSE Keys included Schluessel inbegriffen			
versione dx right version version rechts	versione sx left version version links						CHUB19_SP3	CHUB32	CHESL05	CHTAER16ZC
SAU0530116	SAU0531116	ERA16	1:1	6000	20Nm	X	CHUB19_SP3	CHUB32	CHESL05	CHTAER16ZC

SAUTER
VDI 30
MODULO MOTORIZZATO ORIENTABILE ±90° VDI30 DIN 5480
±90° adjustable angle driven tool VDI30 DIN 5480
Angetriebenes Werkzeug schwenkbar ±90° VDI30 DIN 5480

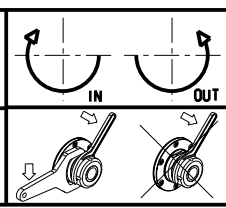

M.T. srl
Via Casino Albini 480
Tel. 0541/956034-957884
Fax 0541/956341
47842 S. GIOVANNI IN M. (RN)
e-mail: mtma@mtmarchetti.com
http://www.mtmarchetti.com

PRODUZIONE MODULI ROTANTI

PAGINA SAU335-2-00

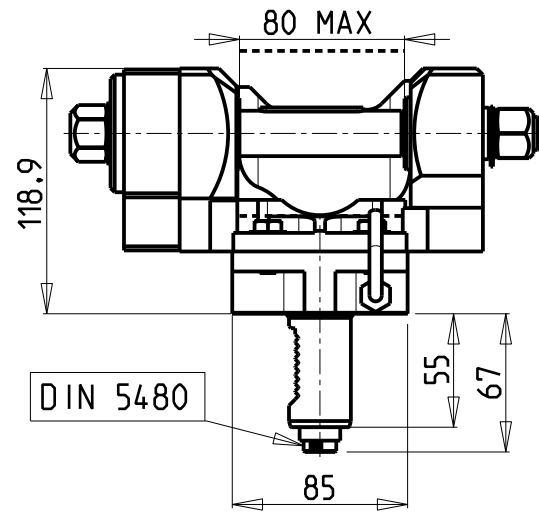
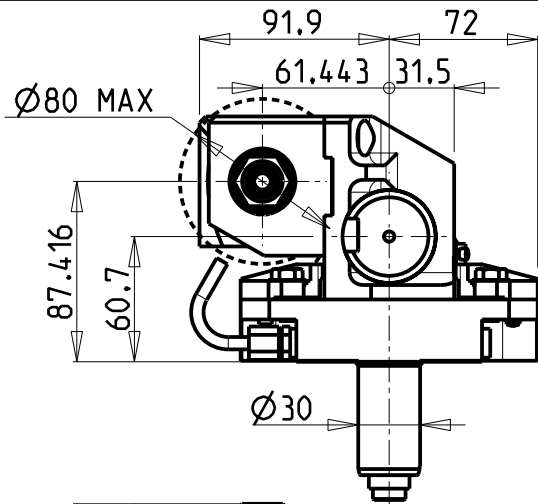

versione dx
right version
version rechts

versione sx
left version
version links

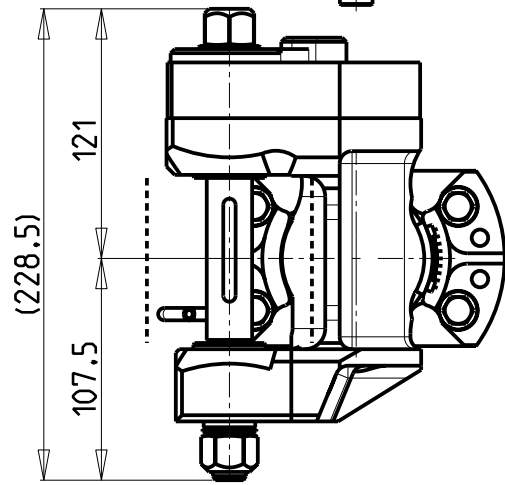
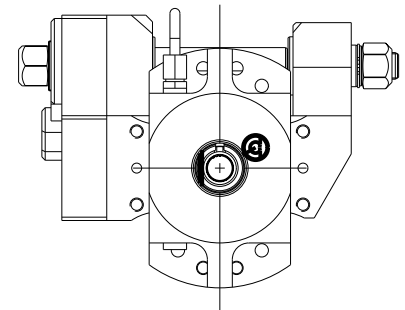
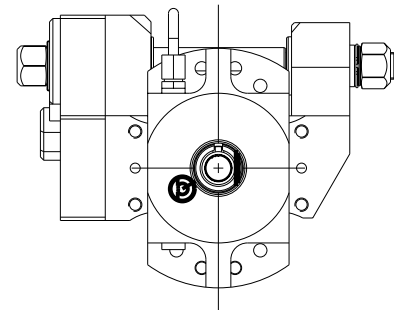

INCLINAZIONE
REGOLABILE ±20°

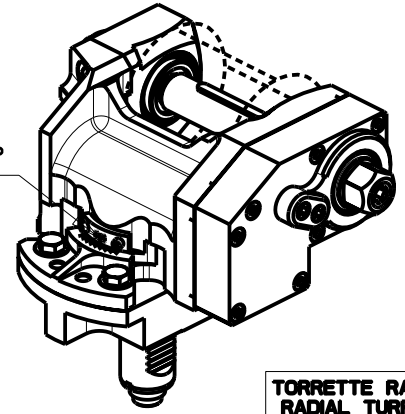

DOTAZIONI - SUPPLIED WITH - AUSSTATTUNG

mm / inch	- N°1 ALBERO + DISTANZIALI - N°1 SHAFT + SPACER - N°1 DORN + ABSTANDSSTUECK
-----------	---

PER ALBERI E DISTANZIALI VEDI PAG. TBL250-1-00
FOR SHAFT END SPACER SEE PAGE TBL250-1-00
FUER DORN UND ABSTANDSSTUECK SEITE TBL250-1-00

TORRETTE RADIALI
RADIAL TURRETS
RADIAL REVOLVER

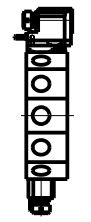

Cod. MT		i	RPM	Coppia Max Max Torque Max Drehmoment	Lubrificazione est. Ext. coolant Aussenkuehlung	D (mm)	D (Inch)	CHIAVI INCLUSE Keys included Schluessel einbegriffen		
versione dx right version version rechts	versione sx left version version links							CHUB24	CHUB13	CHESL08
SAU0021110	SAU0021100	1:1	6000	60Nm	X	16-22-27-32	3/4"-1"-1 1/4"	CHUB24	CHUB13	CHESL08
SAU0022110	SAU0022100	2:1	3000	80Nm	X	16-22-27-32	3/4"-1"-1 1/4"	CHUB24	CHUB13	CHESL08

SAUTER
VDI 30

MODULO MOTORIZZATO PORTACREATORE VDI30 DIN 5480
Driven gear hobber VDI30 DIN 5480
Angetriebenes Zahnradwaelzfraes-Werkzeug VDI30 DIN 5480

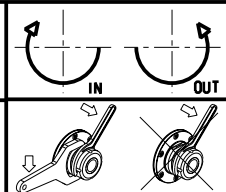

M.T. srl
Via Casino Albini 480
Tel. 0541/956034-957884
Fax 0541/956341
47842 S. GIOVANNI IN M. (RN)
e-mail: mtma@mtmarchetti.com
http://www.mtmarchetti.com

PRODUZIONE MODULI ROTANTI



PAGINA SAU340-2-05