

**TORRETTE ASSIALI
AXIAL TURRETS
AXIAL REVOLVER**

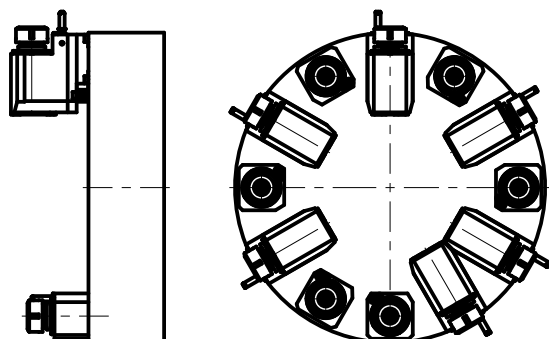

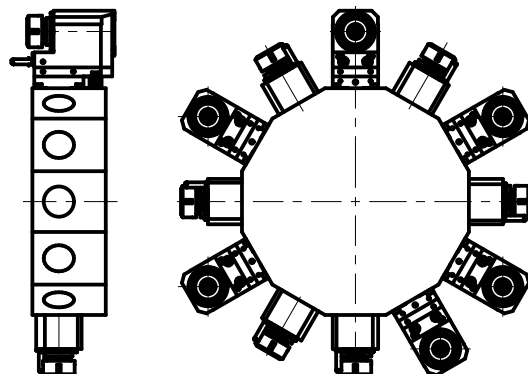



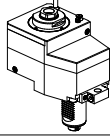
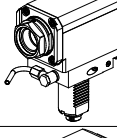
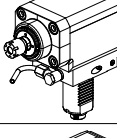
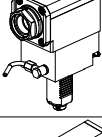
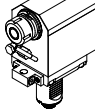

**TORRETTE RADIALI
RADIAL TURRETS
RADIAL REVOLVER**

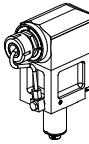
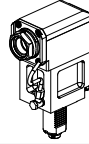
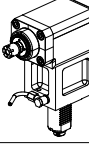
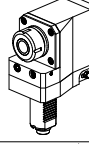
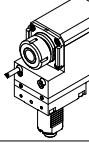
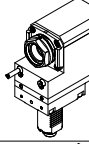
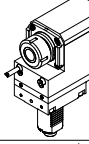
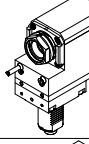
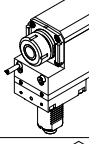
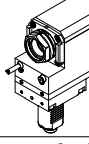
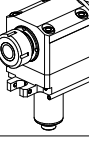
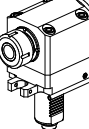

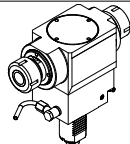
MACCHINE MACHINES MASCHINEN	MODELLI MODELS MODELLE
BOEHRINGER	NG 180/200 - NV 250 - 16 M
COLCHESTER	T 8 MS/MSY
DOOSAN	H 310 - S 390 M - S 550 - Z 280
EMCO	ET 500 - Hyperturn 645/665/690 MC - Maxxturn 65
FMS	M 35 G - NDM 20
GILDEMEISTER	Beta 500/800/1250 - CTX 410/420/450/510/520 - CTV 200/250 - Gamma 1250/2000 GMX 250/300/400 - MF Twin 42/65 - NEF 600 - Twin 42/65/102 - Sprint 65
GRAZIANO	GT 500 G
HURCO	TMM 10
MAGDEBURGER	M 160 - MV 160
MONFORTS	DNC 5/500
NILES	NF 13/16/20 - NV 20
SHAUBLIN	42 L TM/TMI - 65 TM/TM-3Y/TMI
SCHERER FEINBAU	VDZ 120/320/400 - WDZ 250 G
SCHMID	DZ 5
VICTOR	VT II 23/26 - VT A26 SCV/YSCV
VIPER	VT 2300 YMS
WEISSER	Univertor AD/AS/M
WFL	M 30

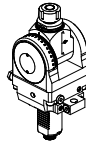
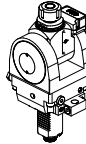
		PAGINA Page Seite
<p>MODULO MOTORIZZATO ASSIALE VDI40 DIN 5480 Axial driven tool VDI40 DIN 5480 Axial angetriebenes Werkzeug VDI40 DIN 5480</p>		SAU017.3.00
<p>MODULO MOTORIZZATO ASSIALE MTSK VDI40 DIN 5480 Axial MTSK driven tool VDI40 DIN 5480 Axial MTSK angetriebenes Werkzeug VDI40 DIN 5480</p>		SAU017.3.00.K
<p>MODULO MOTOR. ASSIALE RIDOTTO I=2:1 DISASSATO 60mm VDI40 DIN 5480 Axial geared-down I=2:1 driven tool re-directed by 60mm VDI40 DIN 5480 Axial angetriebenes Werkzeug untersetzt I=2:1 achsversetzt um 60mm VDI40 DIN 5480</p>		SAU017.3.30
<p>MODULO MOTOR. ASSIALE RIDOTTO I=3:1 DISASSATO 60mm VDI40 DIN 5480 Axial geared-down I=3:1 driven tool re-directed by 60mm VDI40 DIN 5480 Axial angetriebenes Werkzeug untersetzt I=3:1 achsversetzt um 60mm VDI40 DIN 5480</p>		SAU017.3.40
<p>MODULO MOTOR. ASSIALE MOLTIPLICATO I=1:2 DISASSATO 60mm VDI40 DIN 5480 Axial geared-up I=1:2 driven tool re-directed by 60mm VDI40 DIN 5480 Axial angetriebenes Werkzeug uebersetzt I=1:2 achsversetzt um 60mm VDI40 DIN 5480</p>		SAU017.3.60
<p>MODULO MOTORIZZATO ASSIALE 2 USCITE IN Y VDI40 DIN 5480 Axial single side twin head driven tool in Y VDI40 DIN 5480 Axial angetriebenes Werkzeug 2 Ausgaenge in Y VDI40 DIN 5480</p>		SAU017.3.80
<p>MODULO MOTORIZZATO RADIALE VDI40 DIN 5480 H=70mm Radial driven tool VDI40 DIN 5480 H=70mm Radial angetriebenes Werkzeug VDI40 DIN 5480 H=70mm</p>		SAU018.3.00
<p>MODULO MOTORIZZATO RADIALE MTSK VDI40 DIN 5480 H=70mm Radial MTSK driven tool VDI40 DIN 5480 H=70mm Radial MTSK angetriebenes Werkzeug VDI40 DIN 5480 H=70mm</p>		SAU018.3.00.K
<p>MODULO MOTOR. RADIALE MOLTIPLICATO I=1:3 VDI40 DIN 5480 H=70mm Radial geared-up I=1:3 driven tool VDI40 DIN 5480 H=70mm Radial angetriebenes Werkzeug uebersetzt I=1:3 VDI40 DIN 5480 H=70mm</p>		SAU018.3.04
<p>MODULO MOTORIZZATO RADIALE VDI40 DIN 5480 H=100mm Radial driven tool VDI40 DIN 5480 H=100mm Radial angetriebenes Werkzeug VDI40 DIN 5480 H=100mm</p>		SAU018.3.10
<p>MODULO MOTORIZZATO RADIALE MTSK VDI40 DIN 5480 H=100mm Radial MTSK driven tool VDI40 DIN 5480 H=100mm Radial MTSK angetriebenes Werkzeug VDI40 DIN 5480 H=100mm</p>		SAU018.3.10.K
<p>MODULO MOTORIZZATO RADIALE MOLTIPLICATO I=1:3 VDI40 DIN 5480 Radial geared-up I=1:3 driven tool VDI40 DIN 5480 Radial angetriebenes Werkzeug uebersetzt I=1:3 VDI40 DIN 5480</p>		SAU018.3.14

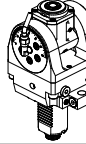
		PAGINA Page Seite
<p>MODULO MOTORIZZATO RADIALE VDI40 DIN 5480 H=130mm Radial driven tool VDI40 DIN 5480 H=130mm Radial angetriebenes Werkzeug VDI40 DIN 5480 H=130mm</p>		SAU018.3.20
<p>MODULO MOTORIZZATO RADIALE MTSK VDI40 DIN 5480 H=130mm Radial MTSK driven tool VDI40 DIN 5480 H=130mm Radial MTSK angetriebenes Werkzeug VDI40 DIN 5480 H=130mm</p>		SAU018.3.20.K
<p>MODULO MOTOR. RADIALE MOLTIPLICATO I=1:3 VDI40 DIN 5480 H=130mm Radial geared-up I=1:3 driven tool VDI40 DIN 5480 H=130mm Radial angetriebenes Werkzeug uebersetzt I=1:3 VDI40 DIN 5480 H=130mm</p>		SAU018.3.24
<p>MODULO MOTORIZZATO RADIALE ARRETRATO VDI40 DIN 5480 H=85mm Radial rear-set driven tool VDI40 DIN 5480 H=85mm Radial angetriebenes Werkzeug zurueckversetzt VDI40 DIN 5480 H=85mm</p>		SAU018.3.60
<p>MODULO MOTORIZZATO RADIALE ARRETRATO VDI40 DIN 5480 H=100mm Radial rear-set driven tool VDI40 DIN 5480 H=100mm Radial angetriebenes Werkzeug zurueckversetzt VDI40 DIN 5480 H=100mm</p>		SAU018.3.70
<p>MODULO MOTORIZZ. RADIALE ARRETRATO MTSK VDI40 DIN 5480 H=100mm Radial MTSK rear-set driven tool VDI40 DIN 5480 H=100mm Radial MTSK angetriebenes Werkzeug zurueckversetzt VDI40 DIN 5480 H=100mm</p>		SAU018.3.70.K
<p>MODULO MOTORIZZATO RADIALE ARRETR. RIDOTTO I=2:1 VDI40 DIN 5480 Radial geared-down I=2:1 rear-set driven tool VDI40 DIN 5480 Radial angetriebenes Werkzeug zurueckversetzt untersetzt I=2:1 VDI40 DIN 5480</p>		SAU018.3.71
<p>MODULO MOTORIZZ. RADIALE ARRETR. MTSK RIDOTTO I=2:1 VDI40 DIN 5480 Radial MTSK geared-down I=2:1 rear-set driven tool VDI40 DIN 5480 Radial MTSK angetriebenes Werkzeug zurueckvers. untersetzt I=2:1 VDI40 DIN 5480</p>		SAU018.3.71.K
<p>MODULO MOTORIZZ. RADIALE ARRETR. MOLTIPLIC. I=1:2 VDI40 DIN 5480 Radial geared-up I=1:2 rear-set driven tool VDI40 DIN 5480 Radial angetriebenes Werkzeug zurueckversetzt uebersetzt I=1:2 VDI40 DIN 5480</p>		SAU018.3.72
<p>MODULO MOTORIZZ. RADIALE ARRETR. MTSK MOLTIPLIC. I=1:2 VDI40 DIN 5480 Radial MTSK geared-up I=1:2 rear-set driven tool VDI40 DIN 5480 Radial MTSK angetriebenes Werkzeug zurueckvers. uebersetzt I=1:2 VDI40 DIN 5480</p>		SAU018.3.72.K
<p>MODULO MOTORIZZATO RADIALE BISPORGENTE VDI40 DIN 5480 H=70mm Radial opposite face twin driven tool VDI40 DIN 5480 H=70mm Radial angetriebenes Werkzeug halb vorspringend VDI40 DIN 5480 H=70mm</p>		SAU019.3.00
<p>MODULO MOTORIZZATO RADIALE BISPORGENTE VDI40 DIN 5480 H=100mm Radial opposite face twin driven tool VDI40 DIN 5480 H=100mm Radial angetriebenes Werkzeug halb vorspringend VDI40 DIN 5480 H=100mm</p>		SAU019.3.10

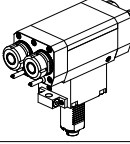
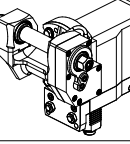
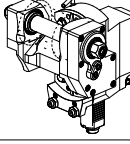
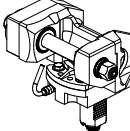
		PAGINA Page Seite
<p>MODULO MOTORIZ RADIALE BISPORG. MOLTIPLICATO 1:2 VDI40 DIN 5480 Radial geared-up 1=1:2 opposite face twin driven tool VDI40 DIN 5480 Radial angetriebenes Werkzeug halb vorspringend uebersetzt 1=1:2 VDI40 DIN 5480</p>		SAU019.3.13
<p>MODULO MOTORIZZATO ORIENTABILE 0-90° VDI40 DIN 5480 0-90° adjustable angle driven tool VDI40 DIN 5480 Angetriebenes Werkzeug schwenkbar 0-90° VDI40 DIN 5480</p>		SAU019.3.50
<p>MODULO MOTORIZZATO ORIENTABILE ±90° VDI40 DIN 5480 ±90° adjustable angle driven tool VDI40 DIN 5480 Angetriebenes Werkzeug schwenkbar ±90° VDI40 DIN 5480</p>		SAU019.3.60
<p>MOD. MOTOR. ORIENTABILE ±90° CON NONIO DIGITALE VDI40 DIN 5480 ±90° adjustable angle driven tool with digital display VDI40 DIN 5480 Angetriebenes Werkzeug schwenkbar ±90° mit digital display VDI40 DIN 5480</p>		SAU019.3.61
<p>MODULO MOTORIZZATO ORIENTABILE ±90° VDI40 DIN 5480 ±90° adjustable angle driven tool VDI40 DIN 5480 Angetriebenes Werkzeug schwenkbar ±90° VDI40 DIN 5480</p>		SAU019.3.70
<p>MOD. MOTOR. ORIENTABILE ±90° CON NONIO DIGITALE VDI40 DIN 5480 ±90° adjustable angle driven tool with digital display VDI40 DIN 5480 Angetriebenes Werkzeug schwenkbar ±90° mit digital display VDI40 DIN 5480</p>		SAU019.3.71
<p>MODULO MOTOR. ORIENTABILE ±90° MOLTIPLICATO 1:2 VDI40 DIN 5480 ±90° adjustable angle driven tool geared-up 1=1:2 VDI40 DIN 5480 Angetriebenes Werkzeug schwenkbar ±90° uebersetzt 1=1:2 VDI40 DIN 5480</p>		SAU019.3.80
<p>MOD. MOT. ORIENTABILE ±90° MOLTIPL 1:2 CON NONIO DIGITALE VDI40 ±90° adjustable angle driven tool geared-up 1=1:2 with digital display VDI40 Antrieb. Werkzeug schwenkbar ±90° uebersetzt 1=1:2 mit digital display VDI40</p>		SAU019.3.81
<p>MODULO MOTORIZZATO RADIALE 2+2 USCITE IN Y VDI40 DIN 5480 Radial multiple 2+2 outlet driven tool in Y VDI40 DIN 5480 Radial angetriebenes Mehrspindel-Werkzeug 2+2 Ausgaenge in Y VDI40 DIN 5480</p>		SAU020.3.00
<p>MODULO MOTORIZZATO PORTACREATORE VDI40 DIN 5480 Driven gear hobber VDI40 DIN 5480 Angetriebenes Zahnradwaelzfraes-Werkzeug VDI40 DIN 5480</p>		SAU340.3.00
<p>MODULO MOTORIZZATO PORTACREATORE VDI40 DIN 5480 Driven gear hobber VDI40 DIN 5480 Angetriebenes Zahnradwaelzfraes-Werkzeug VDI40 DIN 5480</p>		SAU340.3.01
<p>MODULO MOTORIZZATO PORTACREATORE VDI40 DIN 5480 Driven gear hobber VDI40 DIN 5480 Angetriebenes Zahnradwaelzfraes-Werkzeug VDI40 DIN 5480</p>		SAU340.3.05

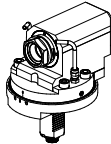
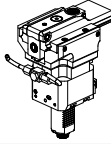
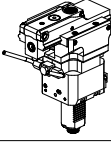
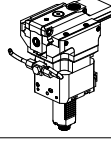
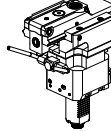
		PAGINA Page Seite
<p>MOD. MOT. ASSIALE MTSK PER POWER SKIVING H=100mm VDI40 DIN 5480 Axial MTSK driven tool for Power Skiving H=100mm VDI40 DIN 5480 Axial MTSK angetriebenes Werkzeug fuer Power Skiving H=100mm VDI40 DIN 5480</p>		SAU350.3.00.K
<p>MODULO MOTORIZZ. STOZZATORE CORSA 50mm H=120mm VDI40 DIN 5480 Slotting driven tool 50mm stroke H=120mm VDI40 DIN 5480 Keilnutenstossmaschine 50mm Hub H=120mm VDI40 DIN 5480</p>		SAU360.3.00
<p>MODULO MOTORIZZ. STOZZATORE CORSA 25mm H=120mm VDI40 DIN 5480 Slotting driven tool 25mm stroke H=120mm VDI40 DIN 5480 Keilnutenstossmaschine 25mm Hub H=120mm VDI40 DIN 5480</p>		SAU360.3.01
<p>MODULO MOTORIZZ. STOZZATORE CORSA 50mm H=100mm VDI40 DIN 5480 Slotting driven tool 50mm stroke H=100mm VDI40 DIN 5480 Keilnutenstossmaschine 50mm Hub H=100mm VDI40 DIN 5480</p>		SAU360.3.10
<p>MODULO MOTORIZZ. STOZZATORE CORSA 25mm H=100mm VDI40 DIN 5480 Slotting driven tool 25mm stroke H=100mm VDI40 DIN 5480 Keilnutenstossmaschine 25mm Hub H=100mm VDI40 DIN 5480</p>		SAU360.3.11

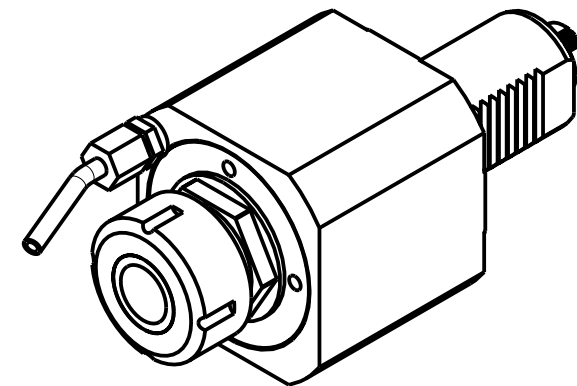
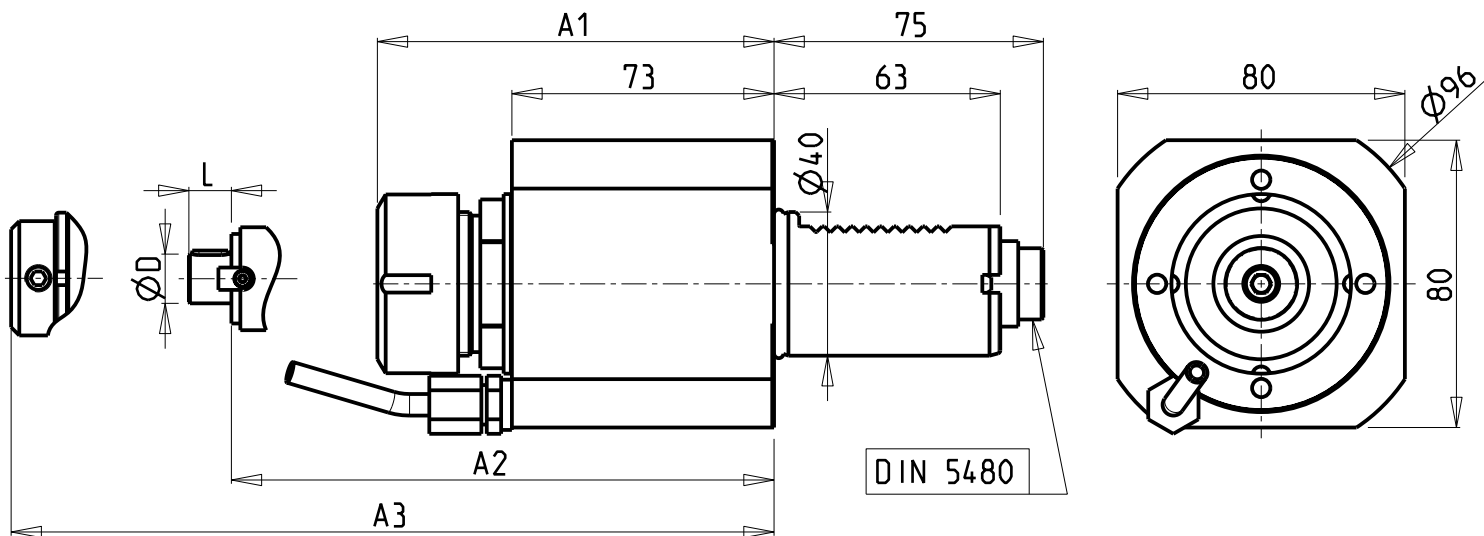

Cod. MT	Mandrino Spindle Spindel	I	RPM	Coppia Max Max Torque Max Drehmoment	Lubrificazione int. Coolant through Innenkuehlung	Lubrificazione est. Ext. coolant Aussenkuehlung	ØD	L	A1	A2	A3	CHIAVI NON INCLUDE Keys not included Schlüssel nicht einbegriffen	
SAU0240140	ER40	1:1	6000	70Nm	-	X	-	-	114	-	-	CHUB41	CHSTER40
212SAU_A32_40D00	ER32	1:1	6000	70Nm	-	X	-	-	110.46	-	-	CHUB41	CHSTER32
212SAU_A32_40D10	ER32	1:1	6000	70Nm	P=30bar	X	-	-	110.46	-	-	CHUB41	CHSTER32
SAU0240125	ER25	1:1	6000	70Nm	-	X	-	-	107.46	-	-	CHUB41	CHSTER25
SAU0241125	ER25	1:1	6000	70Nm	P=30bar	X	-	-	107.46	-	-	CHUB41	CHSTER25
SAU0240320	WELDON20	1:1	6000	70Nm	-	X	-	-	-	-	106.3	-	-
SAU0241320	WELDON20	1:1	6000	70Nm	P=30bar	X	-	-	-	-	106.3	-	-
SAU0240525	WELDON25	1:1	6000	70Nm	-	X	-	-	-	-	106.3	-	-
SAU0241525	WELDON25	1:1	6000	70Nm	P=30bar	X	-	-	-	-	106.3	-	-
SAU0240422	Ø22x19	1:1	6000	70Nm	-	X	22	19	-	96.8	-	CHUB41	CH_VTCROCE_M10 *

- Chiave inclusa
- Key included
- Schlüssel inbegriffen

SAUTER
VDI 40

MODULO MOTORIZZATO ASSIALE VDI40 DIN 5480
Axial driven tool VDI40 DIN 5480
Axial angetriebenes Werkzeug VDI40 DIN 5480

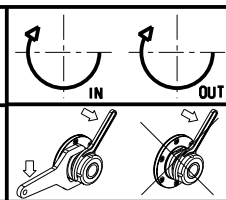

M.T. srl
Via Casino Albini 480
Tel. 0541/956034-957884
Fax 0541/956341
47842 S. GIOVANNI IN M. (RN)
e-mail: mtma@mtmarchetti.com
http://www.mtmarchetti.com

PRODUZIONE MODULI ROTANTI



PAGINA SAU017-3-00

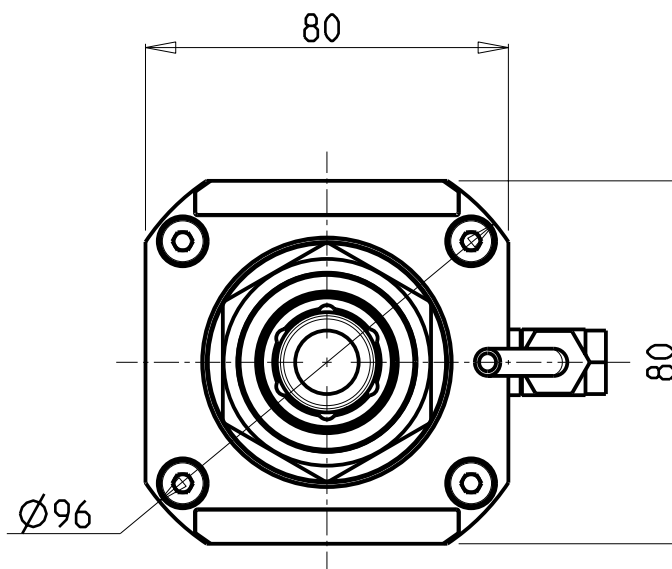
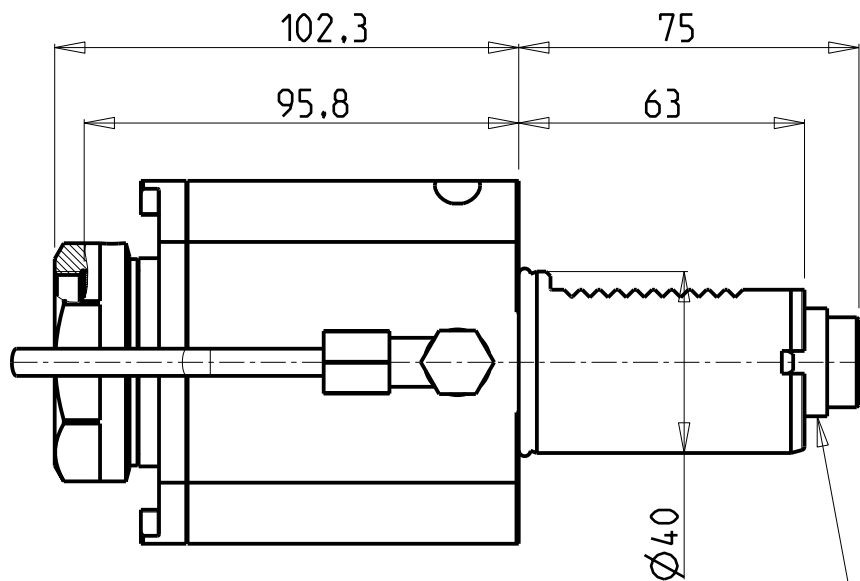

DIN 5480

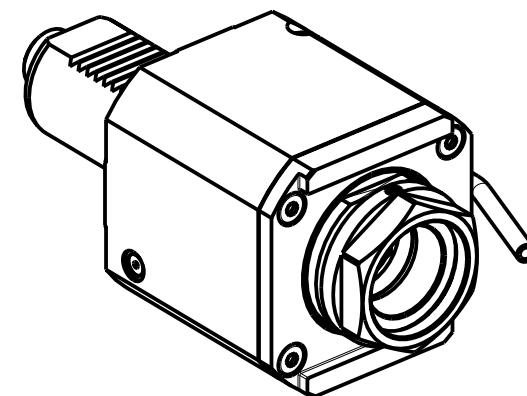

- Chiave inclusa
- Key included
- Schlüssel inbegriffen

PER PORTAUTENSILI MODULARI MTSK-40 VEDI PAG. TBL300-1-40
 FOR MTSK-40 QUICK CHANGE TOOLHOLDERS CLAMPINGS SEE PAGE TBL300-1-40
 FUER MTSK-40 MODULARE WERKZEUGAUFNAHMEN SIEHE SEITE TBL300-1-40

Cod. MT	Mandrino Spindle Spindel	i	RPM	Coppia Max Max Torque Max Drehmoment	Lubrificazione int. Coolant through Innenkuehlung	Lubrificazione est. Ext. coolant Aussenkuehlung	CHIAVI NON INCLUSE Keys not included Schlüssel nicht einbegriffen	
							CHUB46	OKU0650004 *
SAU0550140	MTSK-40	1:1	6000	70Nm	-	X	CHUB46	OKU0650004 *
SAU0550240	MTSK-40	1:1	6000	70Nm	P=30bar	X	CHUB46	OKU0650004 *

SAUTER
VDI 40

MODULO MOTORIZZATO ASSIALE MTSK VDI40 DIN 5480
 Axial MTSK driven tool VDI40 DIN 5480
 Axial MTSK angetriebenes Werkzeug VDI40 DIN 5480

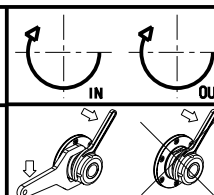

M.T. srl
 Via Casino Albini 480
 Tel. 0541/956034-957884
 Fax 0541/956341
 47842 S. GIOVANNI IN M. (RN)
 e-mail: mtma@mtmarchetti.com
 http://www.mtmarchetti.com

PRODUZIONE MODULI ROTANTI



PAGINA SAU017-3-00-K

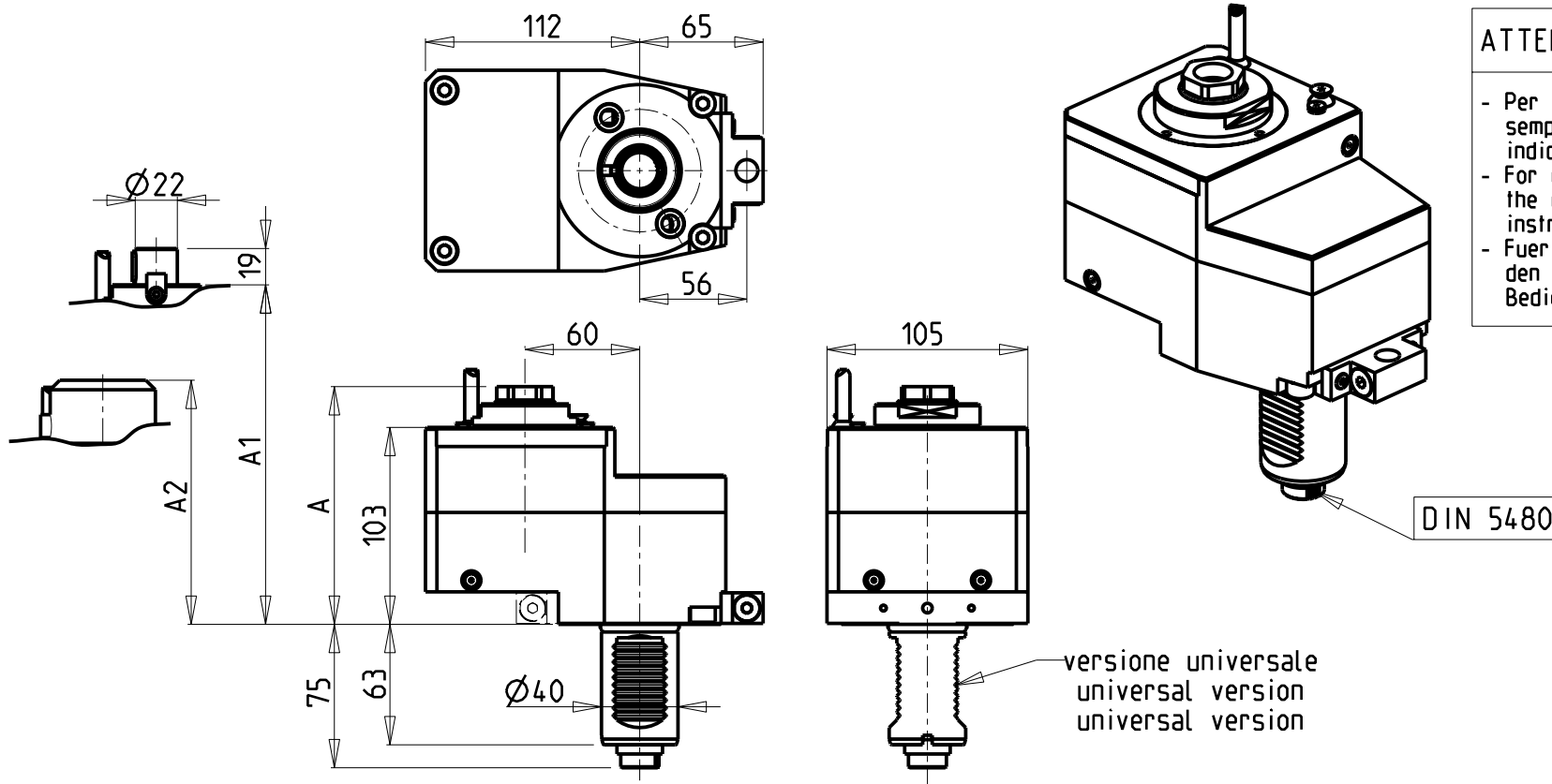

ATTENZIONE - ATTENTION - ACHTUNG

- Per lo smontaggio degli utensili utilizzare sempre la chiave di contrasto come indicato nel manuale d'uso.
- For disassembly of the tools use always the contrast key as mentioned in the user instructions.
- Fuer das Abmontieren der Werkzeuge immer den Gegenschlüssel benutzen wie in der Bedienungsanleitung erwaeht.

DIN 5480

versione universale
universal version
universal version

Cod. MT	Mandrino Spindle Spindel	I	RPM	Coppia Max Max Torque Max Drehmoment	Lubrificazione est. Ext. coolant Aussenkuehlung	Reversibile lato mandrino/contromandrino Reversible sub/main spindle side Umkehrbare Spindel-seite/ Gegenspindel-seite	A	A1	A2	CHIAVI NON INCLUDE Keys not included Schluesel nicht einbegriffen	
SAU0120125	ERA25	2:1	3000	90Nm	X	X	124.33	-	-	CHUB46	CHUB27
SAU0120232	ERA32	2:1	3000	90Nm	X	X	131.53	-	-	CHUB46	CHUB32
SAU0120140	ER40	2:1	3000	90Nm	X	X	143.66	-	-	CHUB46	CHSTER40
SAU0120322	Ø22x19	2:1	3000	90Nm	X	X	-	116	-	CHUB46	CH_VTCROCE_M10 *
SAU0120425	WELDON25	2:1	3000	90Nm	X	X	-	-	137	-	-

• Chiave inclusa

• Key included

• Schluesel inbegriffen

SAUTER
VDI 40

MODULO MOTORIZZATO ASSIALE RIDOTTO I=2:1 DISASSATO 60mm VDI40 DIN 5480
Axial geared-down I=2:1 driven tool re-directed by 60mm VDI40 DIN 5480
Axial angetriebenes Werkzeug untersetzt I=2:1 achsversetzt um 60mm VDI40 DIN 5480

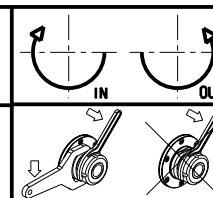

M.T. srl

Via Casino Albini 480
Tel. 0541/956034-957884
Fax 0541/956341
47842 S. GIOVANNI IN M. (RN)
e-mail: mtma@mtmarchetti.com
http://www.mtmarchetti.com

PRODUZIONE MODULI ROTANTI



PAGINA SAU017-3-30

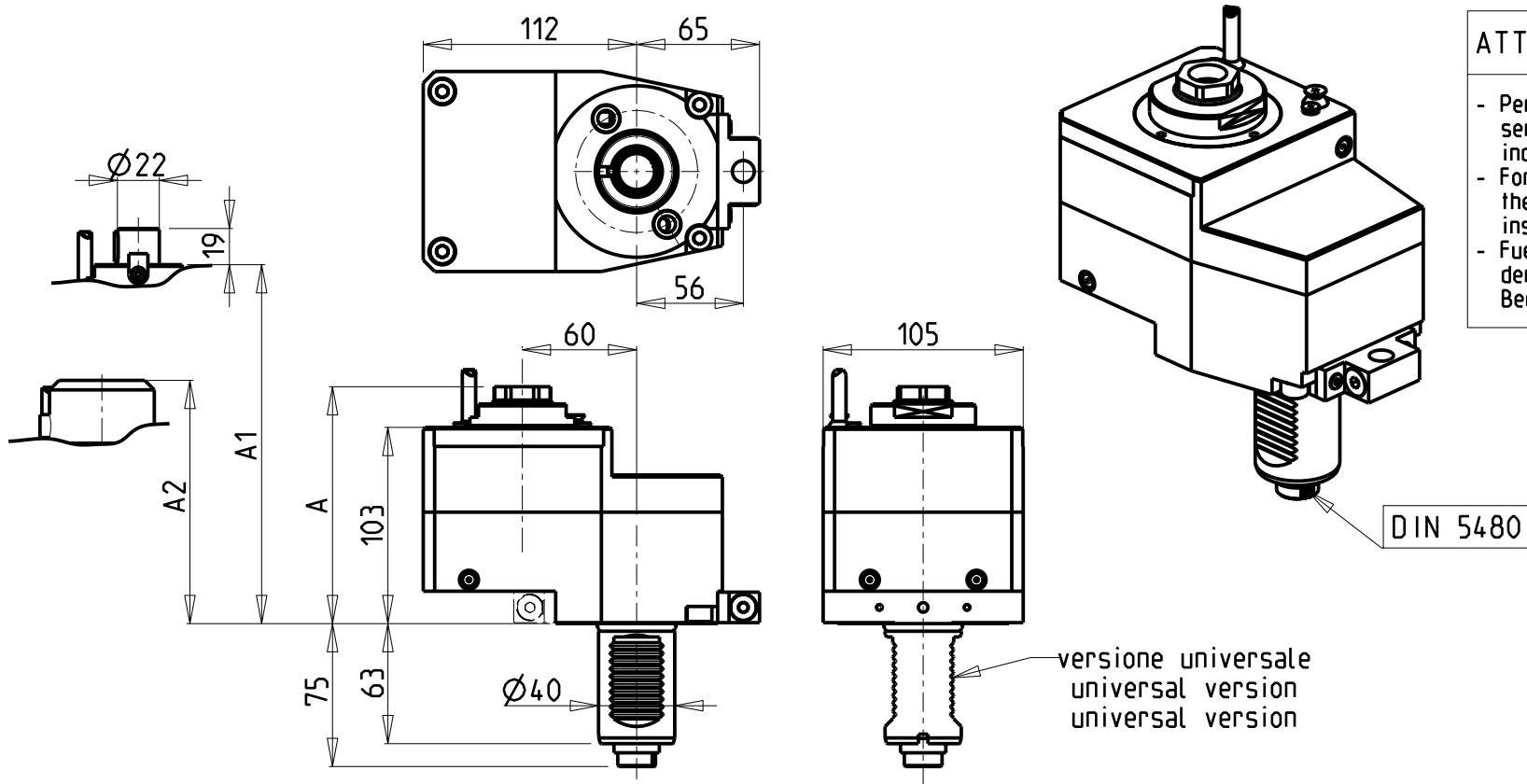

ATTENZIONE - ATTENTION - ACHTUNG

- Per lo smontaggio degli utensili utilizzare sempre la chiave di contrasto come indicato nel manuale d'uso.
- For disassembly of the tools use always the contrast key as mentioned in the user instructions.
- Fuer das Abmontieren der Werkzeuge immer den Gegenschlüssel benutzen wie in der Bedienungsanleitung erwäehnt.

DIN 5480

versione universale
universal version
universal version

Cod. MT	Mandrino Spindle Spindel	I	RPM	Coppia Max Max Torque Max Drehmoment	Lubrificazione est. Ext. coolant Aussenkuehlung	Reversibile lato mandrino/controlmandrino Reversible sub/main spindle side Umkehrbare Spindel-seite/Gegenspindel-seite	A	A1	A2	CHIAVI NON INCLUDE Keys not included Schluessel nicht einbegriffen	
SAU0121125	ERA25	3:1	2000	130Nm	X	X	124.33	-	-	CHUB46	CHUB27
SAU0121232	ERA32	3:1	2000	130Nm	X	X	131.53	-	-	CHUB46	CHUB32
SAU0121140	ER40	3:1	2000	130Nm	X	X	143.66	-	-	CHUB46	CHSTER40
SAU0121322	Ø22x19	3:1	2000	130Nm	X	X	-	116	-	CHUB46	CH_VTCROCE_M10 *
SAU0121425	WELDON25	3:1	2000	130Nm	X	X	-	-	137	-	-

- Chiave inclusa
- Key included
- Schluessel inbegriffen

SAUTER
VDI 40

MODULO MOTORIZZATO ASSIALE RIDOTTO I=3:1 DISASSATO 60mm VDI40 DIN 5480
Axial geared-down I=3:1 driven tool re-directed by 60mm VDI40 DIN 5480
Axial angetriebenes Werkzeug untersetzt I=3:1 achsversetzt um 60mm VDI40 DIN 5480

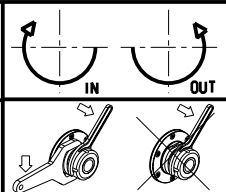

M.T. srl
Via Casino Albini 480
Tel. 0541/956034-957884
Fax 0541/956341
47842 S. GIOVANNI IN M. (RN)
e-mail: mtma@mtmarchetti.com
http://www.mtmarchetti.com

PRODUZIONE MODULI ROTANTI



PAGINA SAU017-3-40

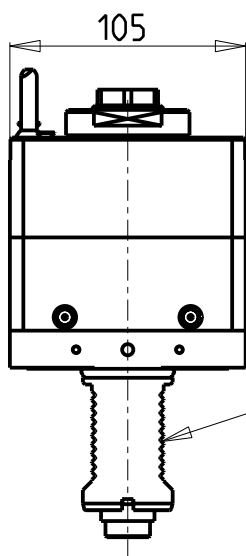
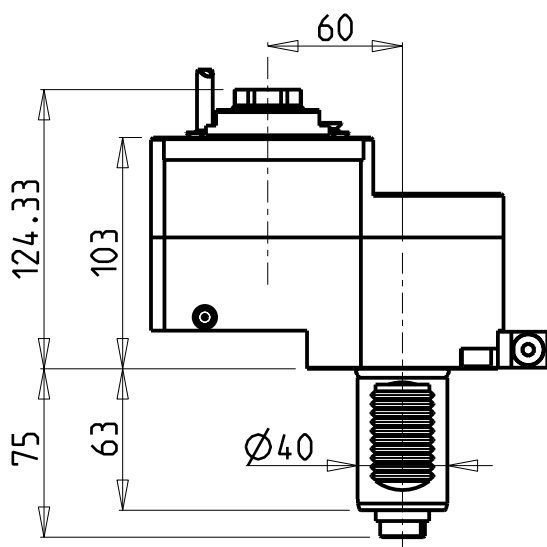
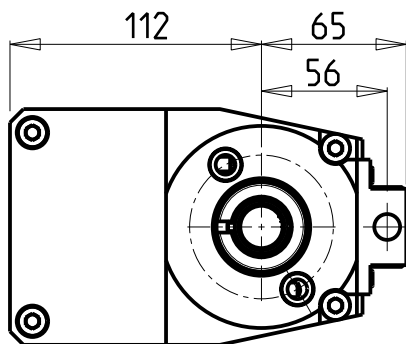

versione universale
universal version
universal version

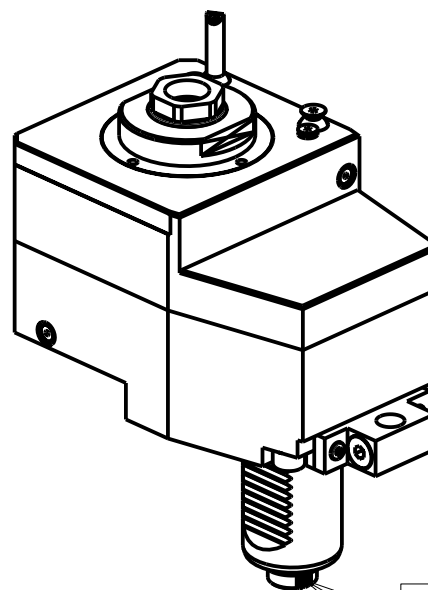

DIN 5480

ATTENZIONE - ATTENTION - ACHTUNG

- Per lo smontaggio degli utensili utilizzare sempre la chiave di contrasto come indicato nel manuale d'uso.
- For disassembly of the tools use always the contrast key as mentioned in the user instructions.
- Fuer das Abmontieren der Werkzeuge immer den Gegenschlüssel benutzen wie in der Bedienungsanleitung erwaeht.

Cod. MT	Mandrino Spindle Spindel	i	RPM	Coppia Max Max Torque Max Drehmoment	Lubrificazione est. Ext. coolant Aussenkuehlung	Reversibile lato mandrino/contromandrino Reversible sub/main spindle side Umkehrbare Spindel-seite/ Gegenspindel-seite	CHIAVI NON INCLUSE Keys not included Schlüssel nicht einbegriffen	
SAU0120525	ERA25	1:2	12000	50Nm	X	X	CHUB46	CHUB27

SAUTER
VDI 40

MODULO MOTORIZZATO ASSIALE MOLTIPLICATO I=1:2 DISASSATO 60mm VDI40 DIN 5480
Axial geared-up I=1:2 driven tool re-directed by 60mm VDI40 DIN 5480
Axial angetriebenes Werkzeug uebersetzt I=1:2 achsversetzt um 60mm VDI40 DIN 5480

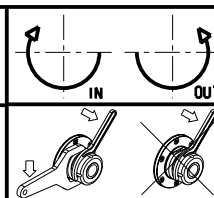

M.T. srl

Via Casino Albini 480
Tel. 0541/956034-957884
Fax 0541/956341
47842 S. GIOVANNI IN M. (RN)
e-mail: mtma@mtmarchetti.com
http://www.mtmarchetti.com

PRODUZIONE MODULI ROTANTI



PAGINA SAU017-3-60

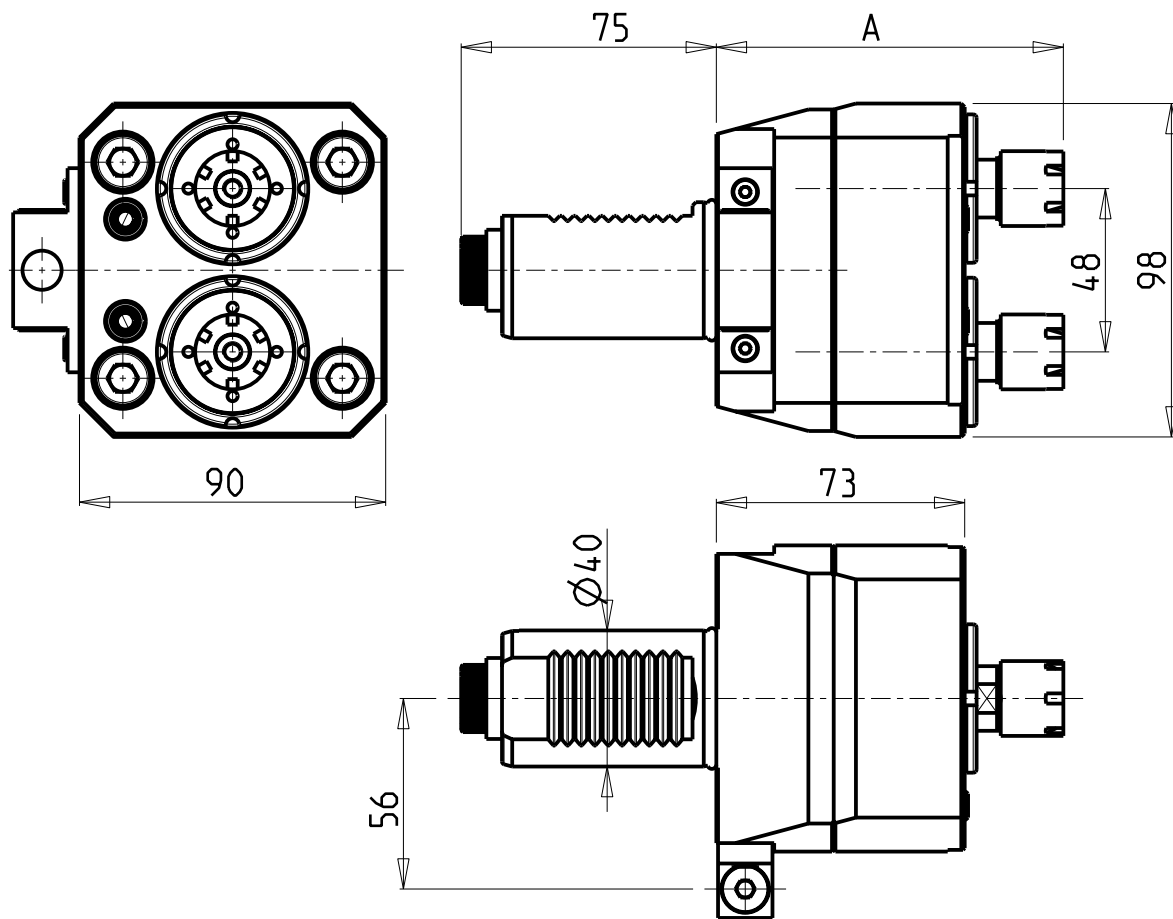

ATTENZIONE - ATTENTION - ACHTUNG

- Per lo smontaggio degli utensili utilizzare sempre la chiave di contrasto come indicato nel manuale d'uso.
- For disassembly of the tools use always the contrast key as mentioned in the user instructions.
- Fuer das Abmontieren der Werkzeuge immer den Gegenschlüssel benutzen wie in der Bedienungsanleitung erwäohnt.

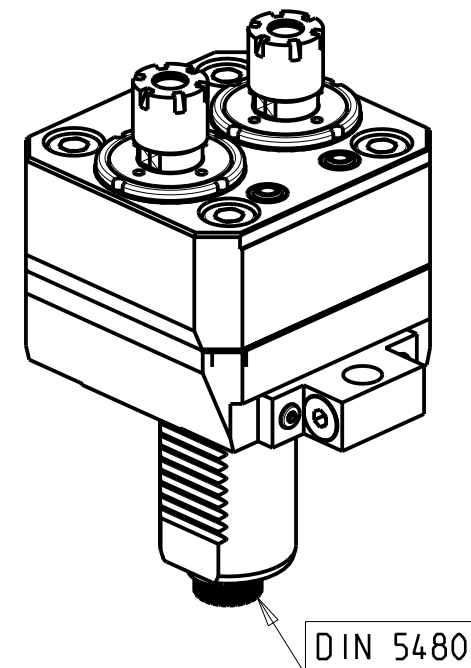

Cod. MT		Mandrino Spindle Spindel	I	RPM	Coppia Max Max Torque Max Drehmoment	Lubrificazione est. Ext. coolant Auslenkuehlung	A	CHIAVI NON INCLUSE Keys not included Schlüssel nicht einbegriffen	
versione dx right version version rechts	versione sx left version version links							CHUB17	CHMNER16
SAU0450216	SAU0451216	ER16	1:1	6000	30Nm	X	102	CHUB17	CHMNER16
SAU0450225	SAU0451225	ER25	1:1	6000	30Nm	X	102.96	CHUB36	CHSTER25

SAUTER
VDI 40

MODULO MOTORIZZATO ASSIALE 2 USCITE IN Y VDI40 DIN 5480
Axial single side twin head driven tool in Y VDI40 DIN 5480
Axial angetriebenes Werkzeug 2 Ausgaenge in Y VDI40 DIN 5480

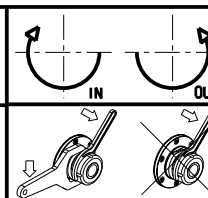

M.T. srl
Via Casino Albini 480
Tel. 0541/956034-957884
Fax 0541/956341
47842 S. GIOVANNI IN M. (RN)
e-mail: mtma@mtmarchetti.com
http://www.mtmarchetti.com

PRODUZIONE MODULI ROTANTI



PAGINA SAU017-3-80

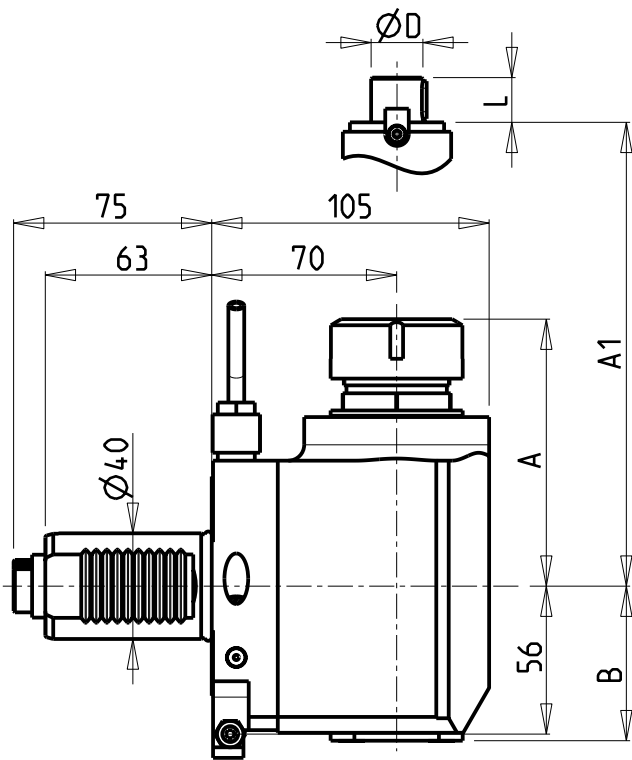

versione dx
right version
version rechts

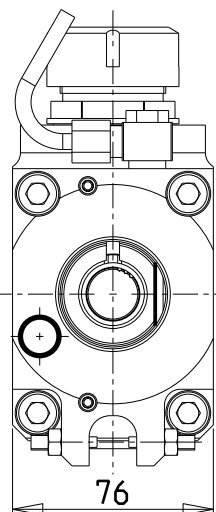

versione sx
left version
version links

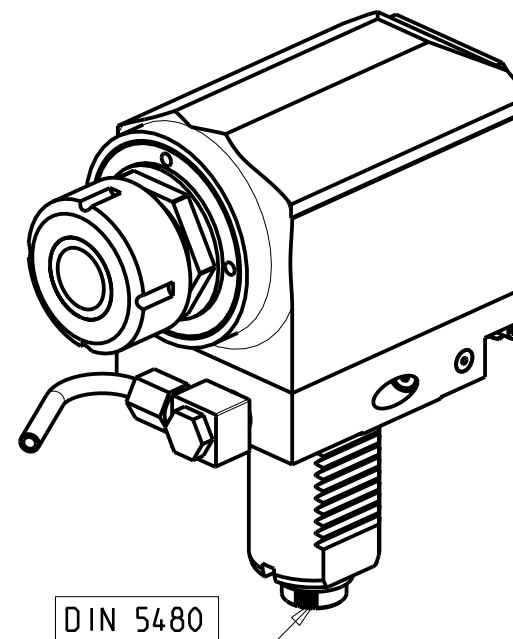
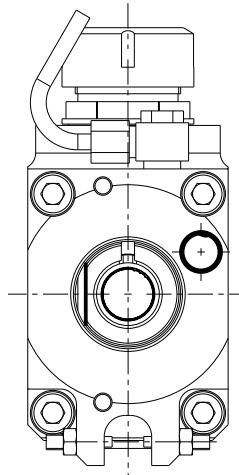

- Chiave inclusa
- Key included
- Schlüssel inbegriffen

Cod. MT		Mandrino Spindle Spindel	I	RPM	Coppia Max Max Torque Max Drehmoment	Lubrificazione int. Coolant through Innenkuehlung	Lubrificazione est. Exl. coolant Aussenkuehlung	A	A1	B	D	L	CHIAVI NON INCLUDE Keys not included Schluessel nicht einbegriffen	
versione dx right version version rechts	versione sx left version version links													
215SAU_R32_40D00	215SAU_R32_40D20	ER32	1:1	6000	70Nm	-	X	101.1	-	58.5	-	-	CHUB41	CHSTER32
215SAU_R32_40D10	215SAU_R32_40D30	ER32	1:1	6000	70Nm	P=70bar	X	101.1	-	82	-	-	CHUB41	CHSTER32
SAU0840140	SAU0841140	ER40	1:1	6000	70Nm	-	X	103.7	-	58.5	-	-	CHUB46	CHSTER40
SAU0840240	SAU0841240	ER40	1:1	6000	70Nm	P=70bar	X	103.7	-	69.5	-	-	CHUB46	CHSTER40
215SAU_R22_40D00	215SAU_R22_40D10	Ø22x19	1:1	6000	70Nm	-	X	-	78.5	58.5	22	19	CHUB41	CH_VTCROCE_M10
215SAU_R27_40D00	215SAU_R27_40D10	Ø27x21	1:1	6000	70Nm	-	X	-	78.5	58.5	27	21	CHUB41	CH_VTCROCE_M12

SAUTER
VDI 40
MODULO MOTORIZZATO RADIALE VDI40 DIN 5480 H=70mm
Radial driven tool VDI40 DIN 5480 H=70mm
Radial angetriebenes Werkzeug VDI40 DIN 5480 H=70mm

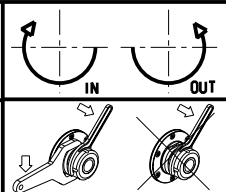

M.T. srl
Via Casino Albini 480
Tel. 0541/956034-957884
Fax 0541/956341
47842 S. GIOVANNI IN M. (RN)
e-mail: mtma@mtmarchetti.com
http://www.mtmarchetti.com

PRODUZIONE MODULI ROTANTI

PAGINA SAU018-3-00

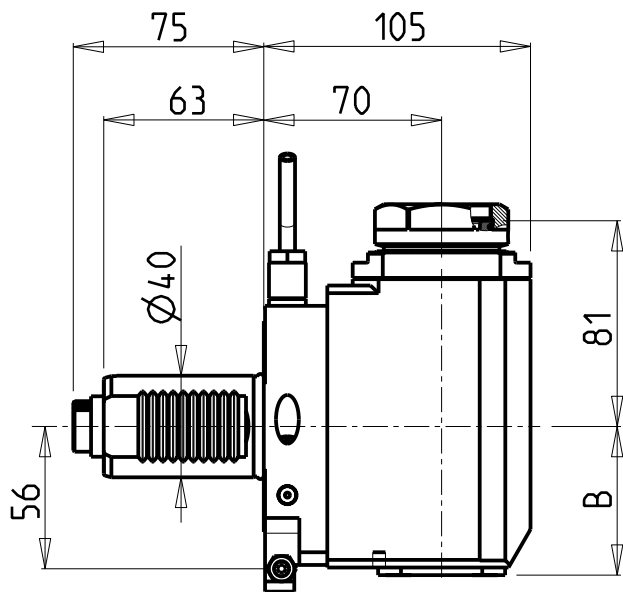

versione dx
right version
version rechts

versione sx
left version
version links

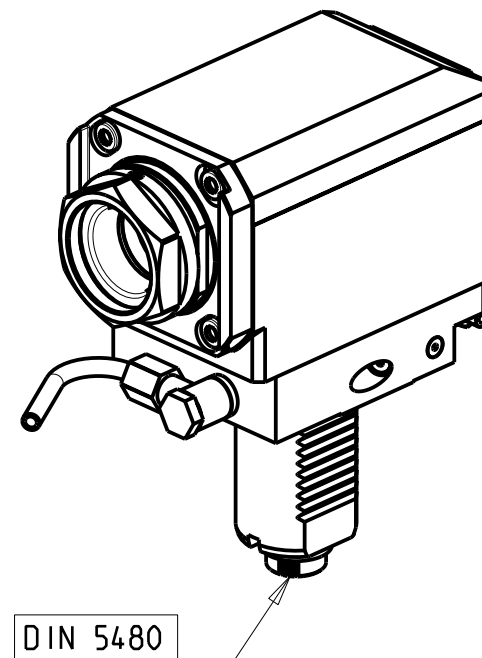
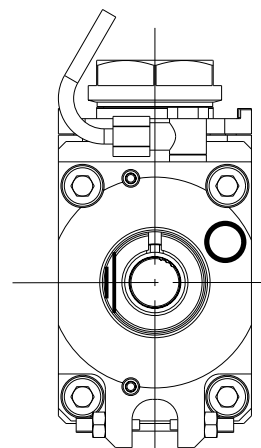
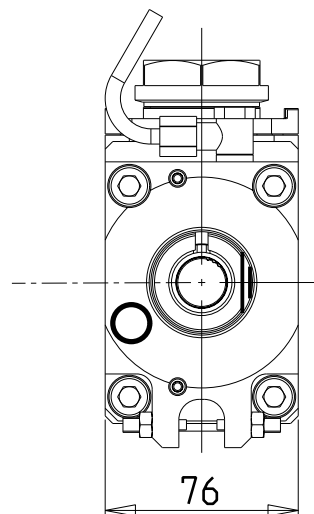

PER PORTAUTENSILI MODULARI MTSK-40 VEDI PAG. TBL300-1-40
FOR MTSK-40 QUICK CHANGE TOOLHOLDERS CLAMPINGS SEE PAGE TBL300-1-40
FUER MTSK-40 MODULARE WERKZEUGAUFNAHMEN SIEHE SEITE TBL300-1-40

- Chiave inclusa
- Key included
- Schlüssel inbegriffen

Cod. MT		Mandrino Spindle Spindel	I	RPM	Coppia Max Max Torque Max Drehmoment	Lubrificazione int. Coolant through Innenkuehlung	Lubrificazione est. Ext. coolant Aussenkuehlung	B	CHIAVI NON INCLUSE Keys not included Schlüssel nicht einbegriffen	
versione dx right version version rechts	versione sx left version version links									
SAU0410140	SAU0411140	MTSK-40	1:1	6000	70Nm	-	X	58.5	CHUB46	OKU0650004 *
SAU0410240	SAU0411240	MTSK-40	1:1	6000	70Nm	P=70bar	X	69.5	CHUB46	OKU0650004 *

SAUTER
VDI 40

MODULO MOTORIZZATO RADIALE MTSK VDI40 DIN 5480 H=70mm
Radial MTSK driven tool VDI40 DIN 5480 H=70mm
Radial MTSK angetriebenes Werkzeug VDI40 DIN 5480 H=70mm

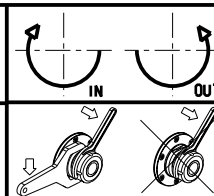

M.T. srl
Via Casino Albini 480
Tel. 0541/956034-957884
Fax 0541/956341
47842 S. GIOVANNI IN M. (RN)
e-mail: mtma@mtmarchetti.com
http://www.mtmarchetti.com

PRODUZIONE MODULI ROTANTI



PAGINA SAU018-3-00-K

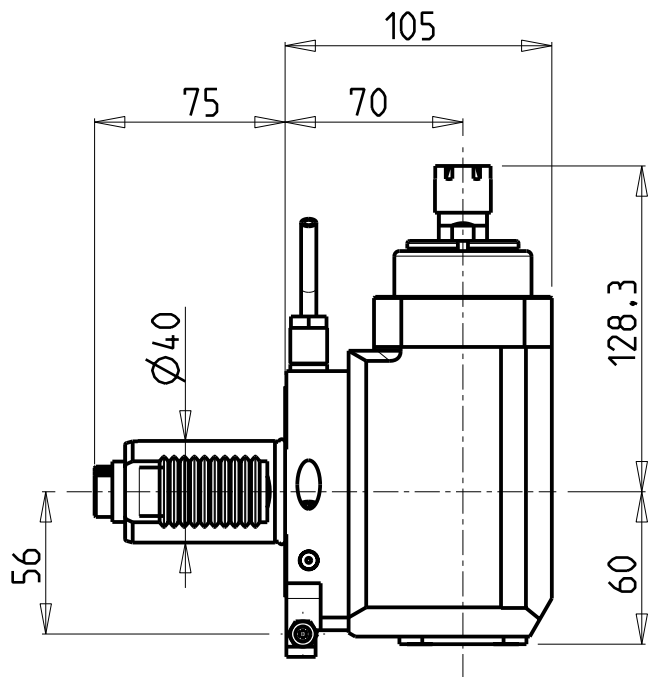

versione dx
right version
version rechts

versione sx
left version
version links

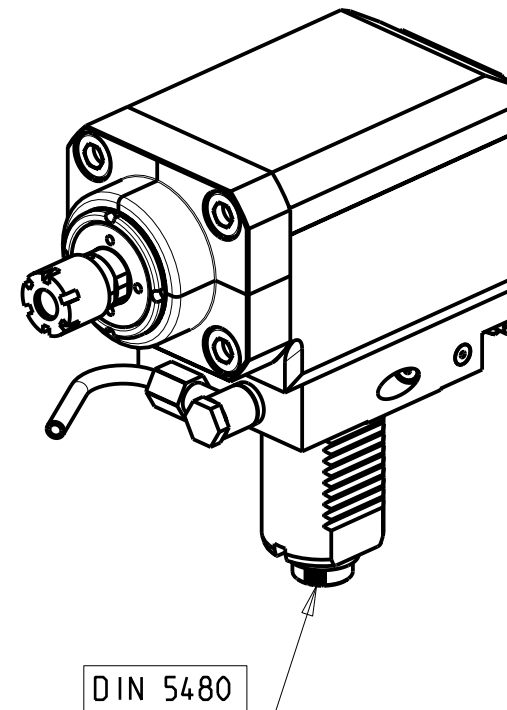
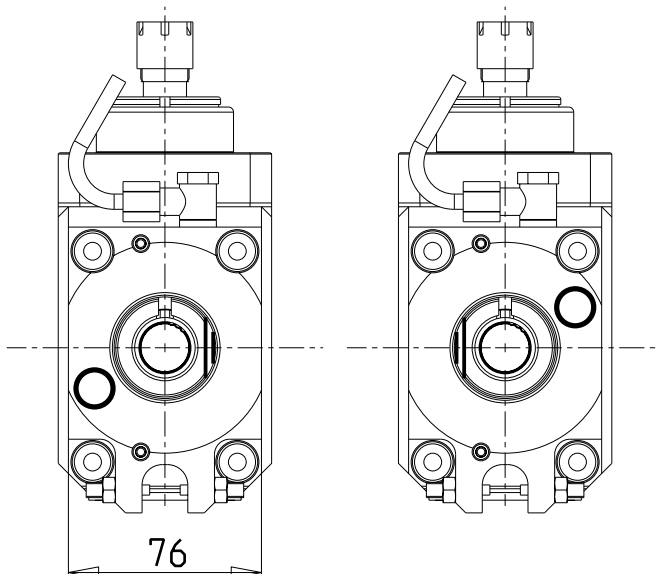

DIN 5480

Cod. MT		Mandrino Spindle Spindel	i	RPM	Coppia Max Max Torque Max Drehmoment	Lubrificazione est. Ext. coolant Aussenkuehlung	CHIAVI INCLUSE Keys included Schlüssel einbegriffen	
versione dx right version version rechts	versione sx left version version links						CHUB17	CHMNER16
SAU0580016	SAU0581016	ER16	1:3	18000	10Nm	X	CHUB17	CHMNER16

SAUTER
VDI 40

MODULO MOTORIZZATO RADIALE MOLTIPLICATO I=1:3 VDI40 DIN 5480 H=70mm
Radial geared-up I=1:3 driven tool VDI40 DIN 5480 H=70mm
Radial angetriebenes Werkzeug uebersetzt I=1:3 VDI40 DIN 5480 H=70mm

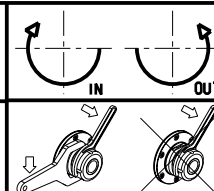

M.T. srl

Via Casino Albini 480
Tel. 0541/956034-957884
Fax 0541/956341

47842 S. GIOVANNI IN M. (RN)
e-mail: mtma@mtmarchetti.com
http://www.mtmarchetti.com

PRODUZIONE MODULI ROTANTI



PAGINA SAU018-3-04

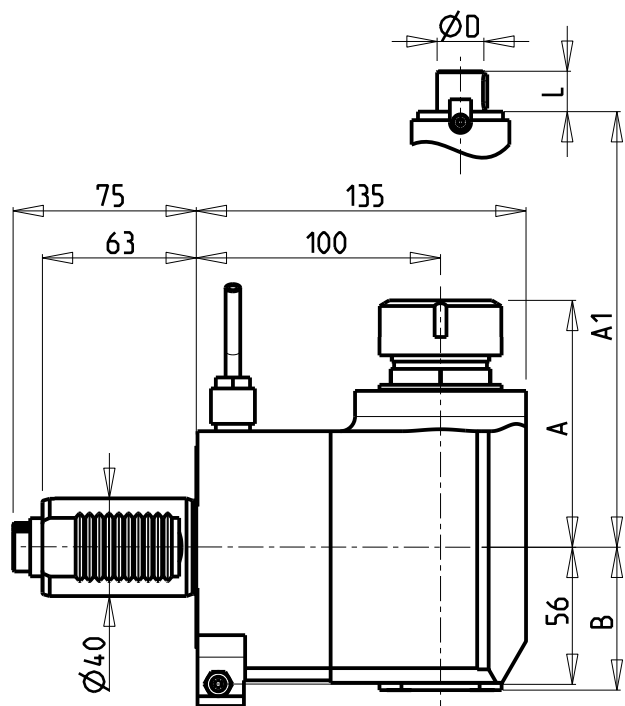

versione dx
right version
version rechts

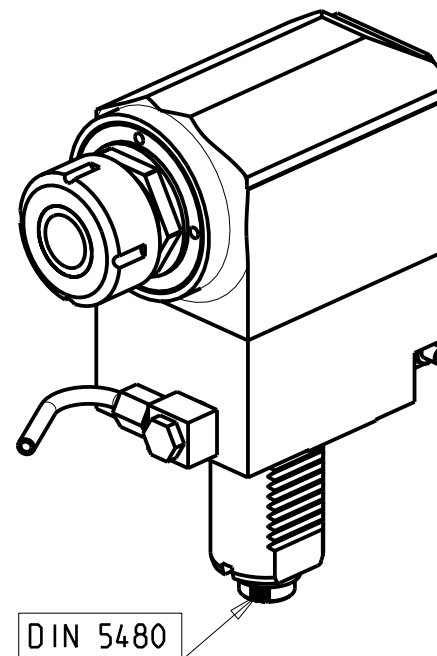
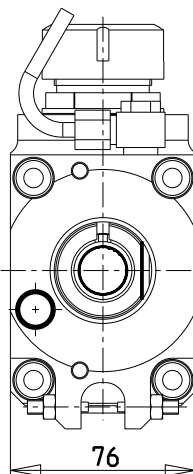

- Chiave inclusa
- Key included
- Schlüssel einbegriffen

Cod. MT	Mandrino Spindle Spindel	I	RPM	Coppia Max Max Torque Max Drehmoment	Lubrificazione int. Coolant through Innenkuhlung	Lubrificazione est. Ext. coolant Aussenkuhlung	A	A1	B	D	L	CHIAVI NON INCLUSE Keys not included Schlüssel nicht einbegriffen	
213SAU_R32_40D00	ER32	1:1	6000	70Nm	-	X	101.1	-	58.5	-	-	CHUB41	CHSTER32
213SAU_R32_40D10	ER32	1:1	6000	70Nm	P=70bar	X	101.1	-	82	-	-	CHUB41	CHSTER32
SAU0820140	ER40	1:1	6000	70Nm	-	X	103.7	-	58.5	-	-	CHUB46	CHSTER40
SAU0820240	ER40	1:1	6000	70Nm	P=70bar	X	103.7	-	69.5	-	-	CHUB46	CHSTER40
213SAU_R22_40D00	Ø22x19	1:1	6000	70Nm	-	X	-	78.5	58.5	22	19	CHUB41	CH_VTCROCE_M10 ▪
213SAU_R27_40D00	Ø27x21	1:1	6000	70Nm	-	X	-	78.5	58.5	27	21	CHUB41	CH_VTCROCE_M12 ▪

SAUTER
VDI 40
MODULO MOTORIZZATO RADIALE VDI40 DIN 5480 H=100mm
Radial driven tool VDI40 DIN 5480 H=100mm
Radial angetriebenes Werkzeug VDI40 DIN 5480 H=100mm

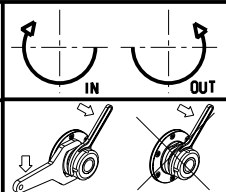

M.T. srl
Via Casino Albini 480
Tel. 0541/956034-957884
Fax 0541/956341
47842 S. GIOVANNI IN M. (RN)
e-mail: mtma@mtmarchetti.com
http://www.mtmarchetti.com

PRODUZIONE MODULI ROTANTI

PAGINA SAU018-3-10

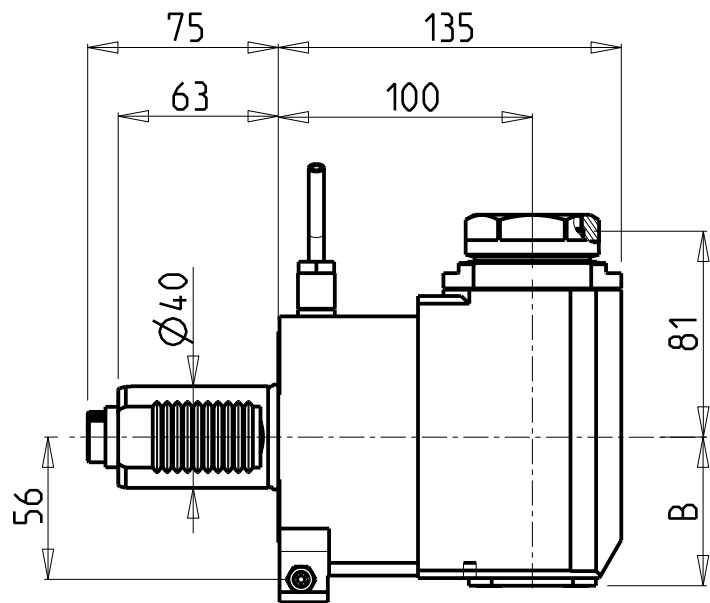

versione dx
right version
version rechts

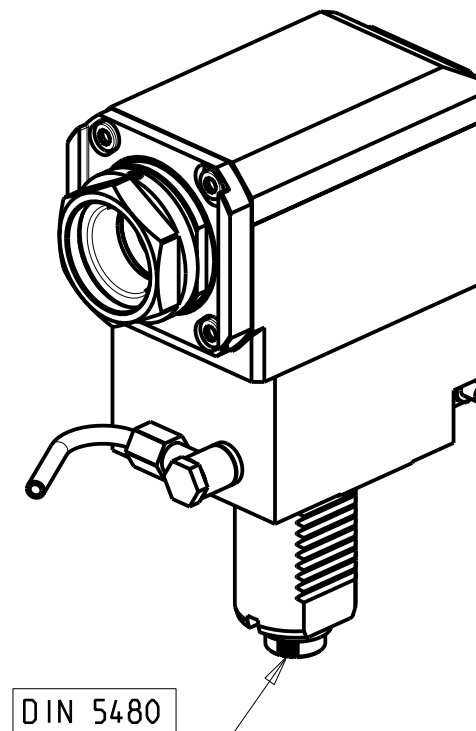
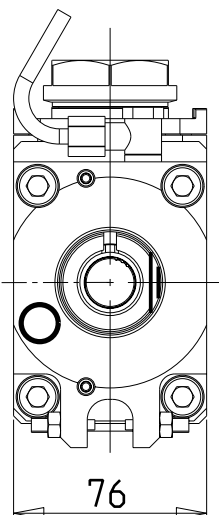

DIN 5480

PER PORTAUTENSILI MODULARI MTSK-40 VEDI PAG. TBL300-1-40
FOR MTSK-40 QUICK CHANGE TOOLHOLDERS CLAMPINGS SEE PAGE TBL300-1-40
FUER MTSK-40 MODULARE WERKZEUGAUFNAHMEN SIEHE SEITE TBL300-1-40

Cod. MT	Mandrino Spindle Spindel	I	RPM	Coppia Max Max Torque Max Drehmoment	Lubrificazione int. Coolant through Innenkuehlung	Lubrificazione est. Ext. coolant Aussenkuehlung	B	CHIAVI NON INCLUSE Keys not included Schluessel nicht einbegriffen	
								CHUB46	OKU0650004 *
SAU0420140	MTSK-40	1:1	6000	70Nm	-	X	58.5	CHUB46	OKU0650004 *
SAU0420240	MTSK-40	1:1	6000	70Nm	P=70bar	X	69.5	CHUB46	OKU0650004 *

- Chiave inclusa
- Key included
- Schluessel inbegriffen

SAUTER
VDI 40

MODULO MOTORIZZATO RADIALE MTSK VDI40 DIN 5480 H=100mm
Radial MTSK driven tool VDI40 DIN 5480 H=100mm
Radial MTSK angetriebenes Werkzeug VDI40 DIN 5480 H=100mm

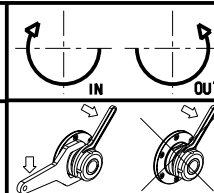

M.T. srl

Via Casino Albini 480
Tel. 0541/956034-957884
Fax 0541/956341
47842 S. GIOVANNI IN M. (RN)
e-mail: mtma@mtmarchetti.com
http://www.mtmarchetti.com

PRODUZIONE MODULI ROTANTI



PAGINA SAU018-3-10-K

versione universale
universal version
universal version

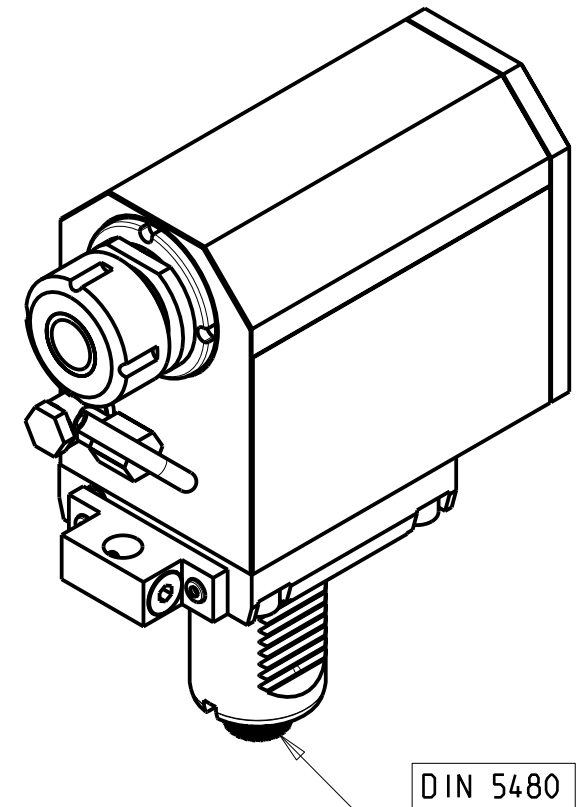
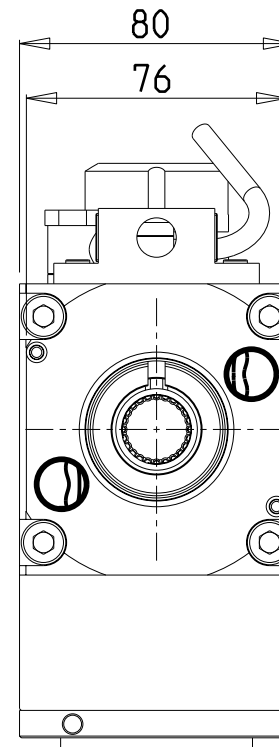
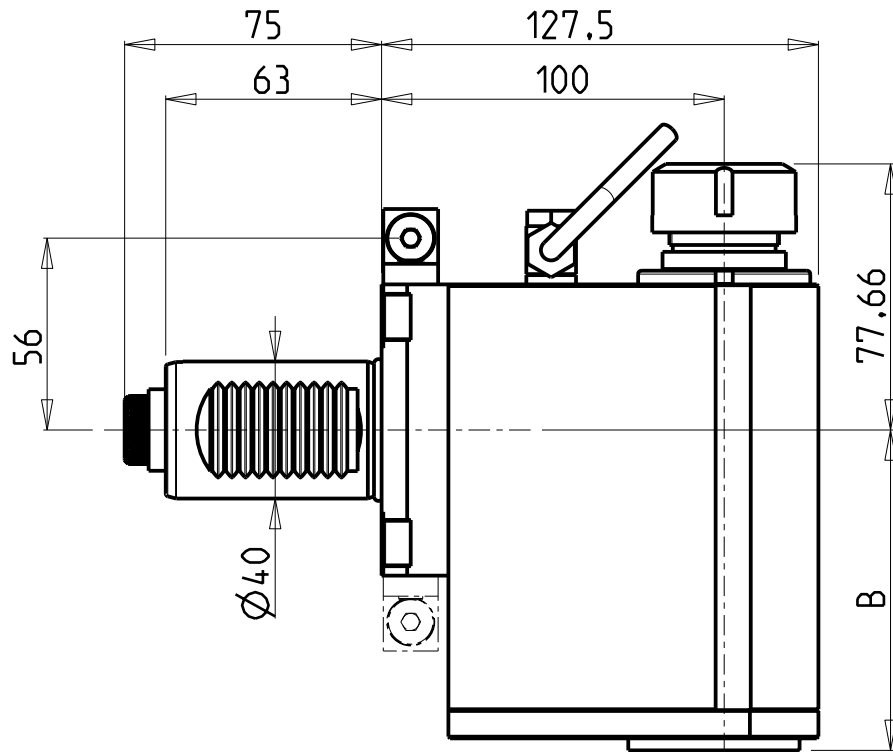

DIN 5480

Cod. MT	Mandrino Spindle Spindel	i	RPM MAX	Coppia Max Max Torque Max Drehmoment	Lubrificazione int. Coolant through Innenkuehlung	Lubrificazione est. Ext. coolant Aussenkuehlung	B	CHIAVI NON INCLUSE Keys not included Schlüssel nicht einbegriffen	
SAU0310125	ER25	1:3	12000	40Nm		X	93.5	CHUB36	CHSTER25
SAU0310225	ER25	1:3	12000	40Nm	P=70bar	X	101.5	CHUB36	CHSTER25

SAUTER
VDI 40

MODULO MOTORIZZATO RADIALE MOLTIPLICATO I=1:3 VDI40 DIN 5480
Radial geared-up I=1:3 driven tool VDI40 DIN 5480
Radial angetriebenes Werkzeug uebersetzt I=1:3 VDI40 DIN 5480

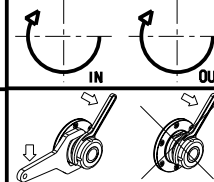

M.T. srl

Via Casino Albini 480
Tel. 0541/956034-957884
Fax 0541/956341
47842 S. GIOVANNI IN M. (RN)
e-mail: mtma@mtmarchetti.com
http://www.mtmarchetti.com

PRODUZIONE MODULI ROTANTI



PAGINA SAU018-3-14

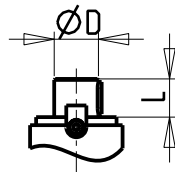
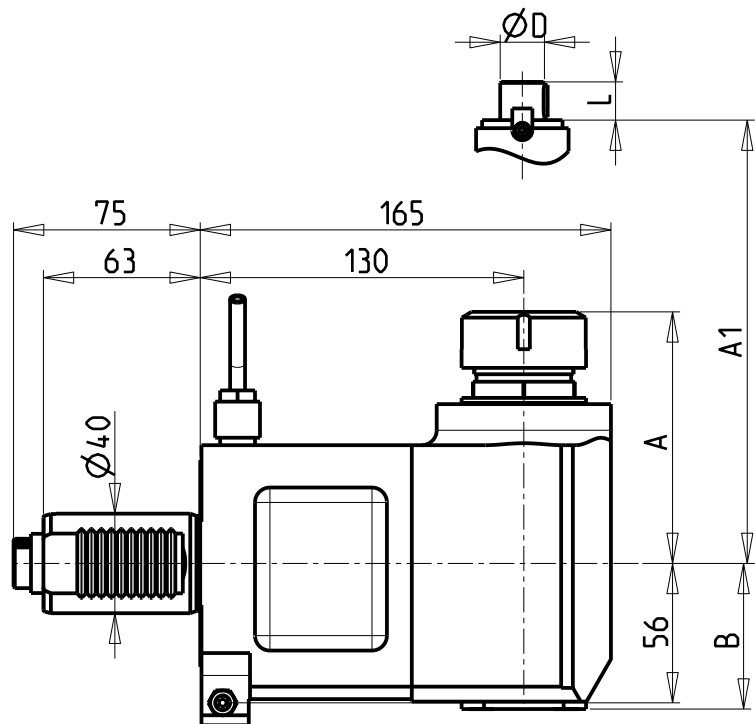

versione dx
right version
version rechts

versione sx
left version
version links

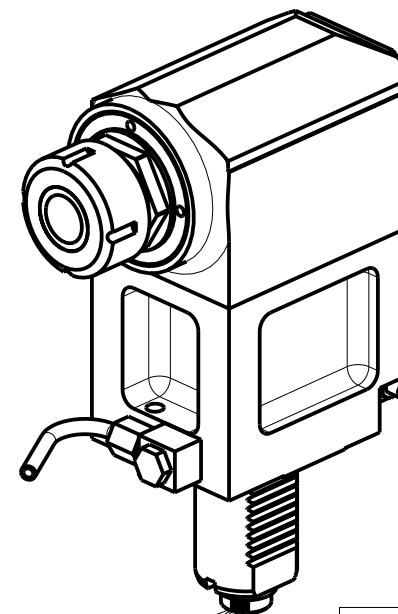
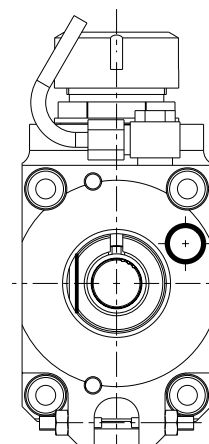
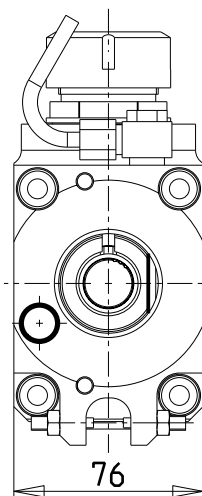

DIN 5480

- Chiave inclusa
- Key included
- Schlüssel inbegriffen

Cod. MT		Mandrino Spindle Spindel	I	RPM	Coppia Max Max Torque Max Drehmoment	Lubrificazione int. Coolant through Innenkuehlung	Lubrificazione est. Ext. coolant Aussenkuehlung	A	A1	B	D	L	CHIAVI NON INCLUDE Keys not included Schlüssel nicht einbegriffen	
versione dx right version version rechts	versione sx left version version links													
213SAU_R32_40D20	213SAU_R32_40D30	ER32	1:1	6000	70Nm	-	X	101.1	-	58.5	-	-	CHUB41	CHSTER32
213SAU_R32_40D40	213SAU_R32_40D50	ER32	1:1	6000	70Nm	P=70bar	X	101.1	-	82	-	-	CHUB41	CHSTER32
SAU0830140	SAU0831140	ER40	1:1	6000	70Nm	-	X	103.7	-	58.5	-	-	CHUB46	CHSTER40
SAU0830240	SAU0831240	ER40	1:1	6000	70Nm	P=70bar	X	103.7	-	69.5	-	-	CHUB46	CHSTER40
213SAU_R22_40D20	213SAU_R22_40D30	Ø22x19	1:1	6000	70Nm	-	X	-	78.5	58.5	22	19	CHUB41	CH_VTCROCE_M10
213SAU_R27_40D20	213SAU_R27_40D30	Ø27x21	1:1	6000	70Nm	-	X	-	78.5	58.5	27	21	CHUB41	CH_VTCROCE_M12

SAUTER
VDI 40

MODULO MOTORIZZATO RADIALE VDI40 DIN 5480 H=130mm
Radial driven tool VDI40 DIN 5480 H=130mm
Radial angetriebenes Werkzeug VDI40 DIN 5480 H=130mm

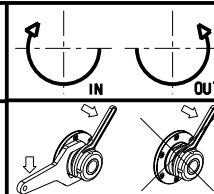

M.T. srl

Via Casino Albini 480
Tel. 0541/956034-957884
Fax 0541/956341
47842 S. GIOVANNI IN M. (RN)
e-mail: mtma@mtmarchetti.com
http://www.mtmarchetti.com

PRODUZIONE MODULI ROTANTI



PAGINA SAU018-3-20

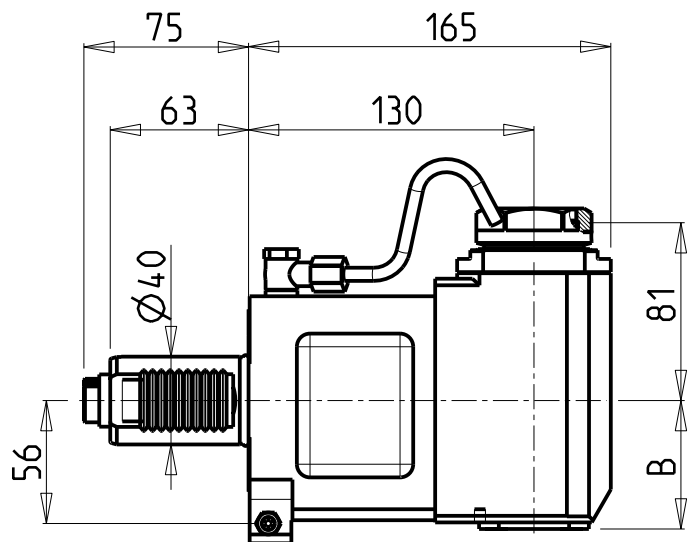

versione dx
right version
version rechts

versione sx
left version
version links

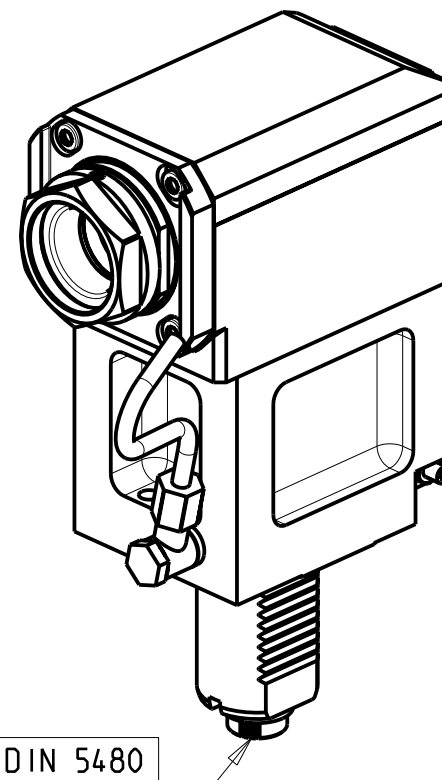
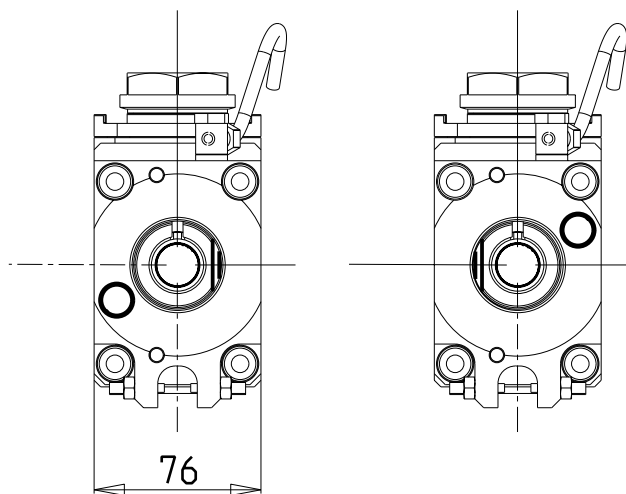

DIN 5480

- Chiave inclusa
- Key included
- Schluessel inbegriffen

PER PORTAUTENSILI MODULARI MTSK-40 VEDI PAG. TBL300-1-40
FOR MTSK-40 QUICK CHANGE TOOLHOLDERS CLAMPINGS SEE PAGE TBL300-1-40
FUER MTSK-40 MODULARE WERKZEUGAUFNAHMEN SIEHE SEITE TBL300-1-40

Cod. MT		Mandrino Spindle Spindel	I	RPM	Coppia Max Max Torque Max Drehmoment	Lubrificazione int. Coolant through Innenkuehlung	Lubrificazione est. Ext. coolant Aussenkuehlung	B	CHIAVI NON INCLUSE Keys not included Schluessel nicht einbegriffen	
versione dx right version version rechts	versione sx left version version links									
SAU0430140	SAU0431140	MTSK-40	1:1	6000	70Nm	-	X	58.5	CHUB46	OKU0650004 •
SAU0430240	SAU0431240	MTSK-40	1:1	6000	70Nm	P=70bar	X	69.5	CHUB46	OKU0650004 •

SAUTER
VDI 40

MODULO MOTORIZZATO RADIALE MTSK VDI40 DIN 5480 H=130mm
Radial MTSK driven tool VDI40 DIN 5480 H=130mm
Radial MTSK angetriebenes Werkzeug VDI40 DIN 5480 H=130mm

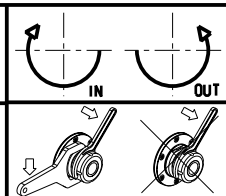

M.T. srl
Via Casino Albini 480
Tel. 0541/956034-957884
Fax 0541/956341
47842 S. GIOVANNI IN M. (RN)
e-mail: mtma@mtmarchetti.com
http://www.mtmarchetti.com

PRODUZIONE MODULI ROTANTI



PAGINA SAU018-3-20-K

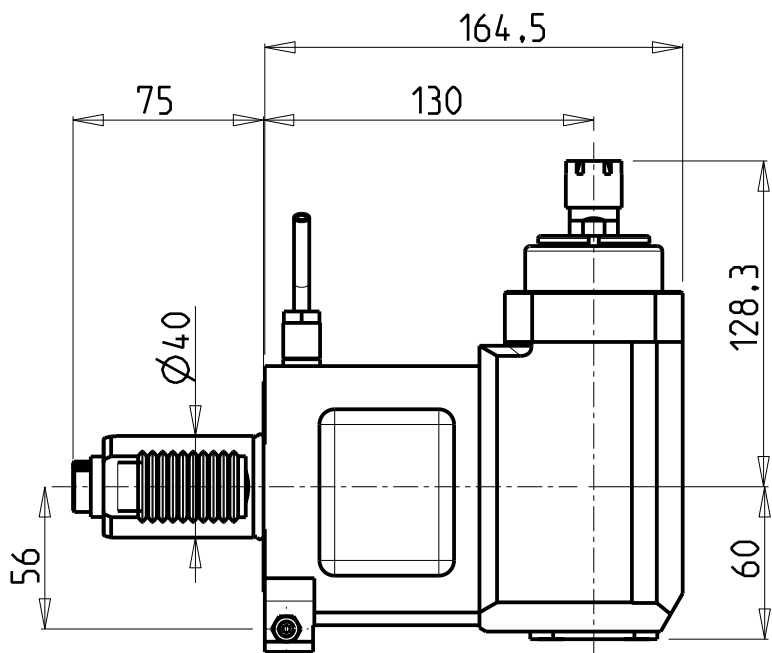

versione dx
right version
version rechts

versione sx
left version
version links

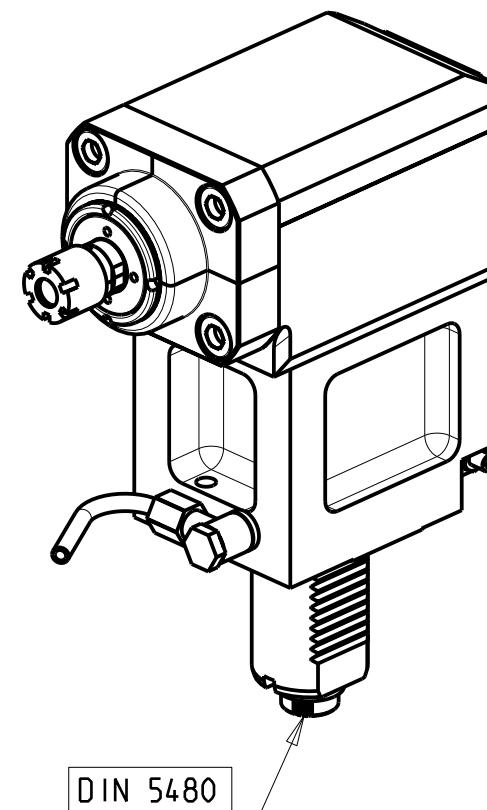
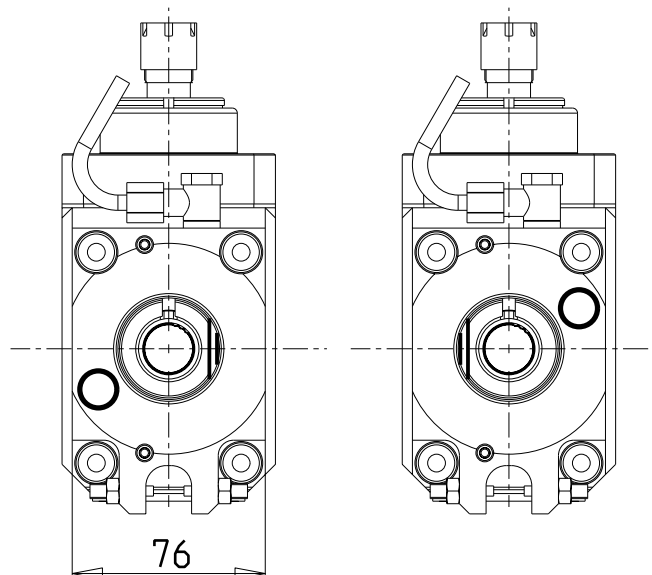

DIN 5480

Cod. MT		Mandrino Spindle Spindel	i	RPM	Coppia Max Max Torque Max Drehmoment	Lubrificazione est. Ext. coolant Aussenkuehlung	CHIAVI INCLUSE Keys included Schlüssel einbegriffen	
versione dx right version version rechts	versione sx left version version links						CHUB17	CHMNER16
SAU0600016	SAU0601016	ER16	1:3	18000	10Nm	X	CHUB17	CHMNER16

SAUTER
VDI 40

MODULO MOTORIZZATO RADIALE MOLTIPLICATO I=1:3 VDI40 DIN 5480 H=130mm
Radial geared-up I=1:3 driven tool VDI40 DIN 5480 H=130mm
Radial angetriebenes Werkzeug uebersetzt I=1:3 VDI40 DIN 5480 H=130mm

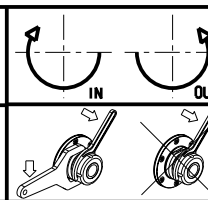

M.T. srl

Via Casino Albini 480
Tel. 0541/956034-957884
Fax 0541/956341
47842 S. GIOVANNI IN M. (RN)
e-mail: mtma@mtmarchetti.com
http://www.mtmarchetti.com

PRODUZIONE MODULI ROTANTI



PAGINA SAU018-3-24

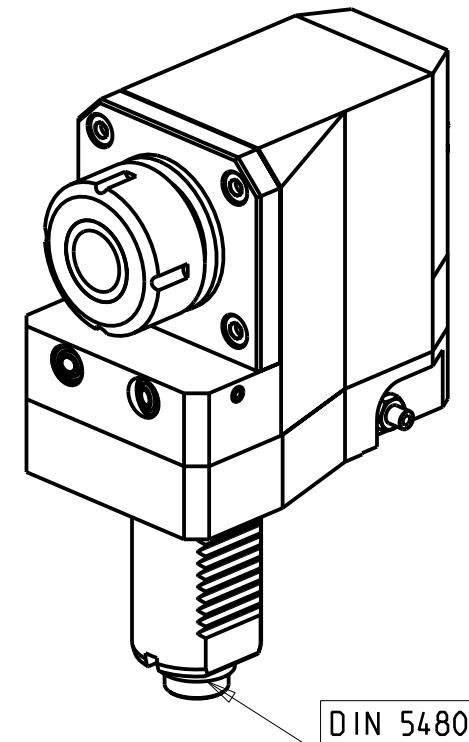
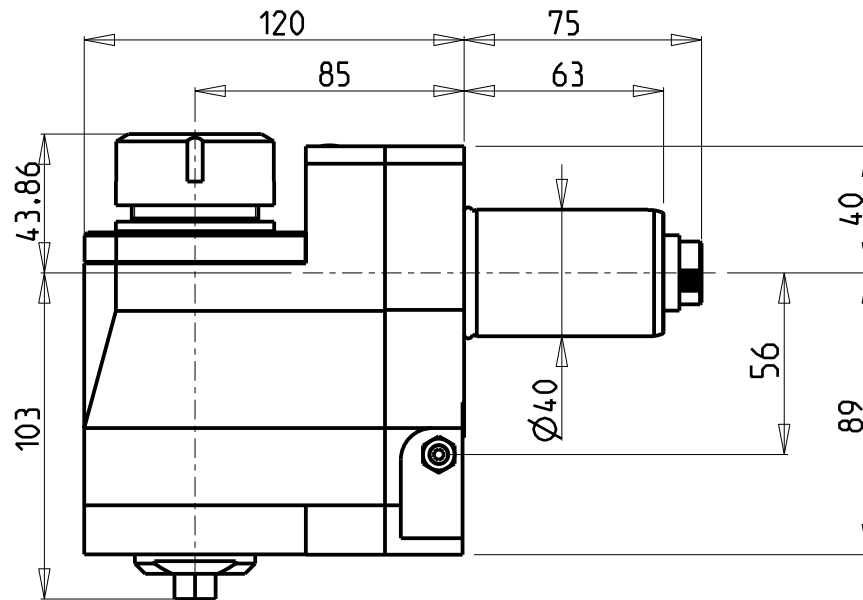
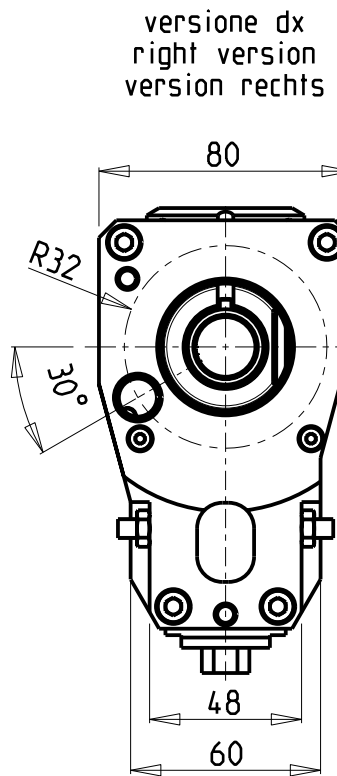

DIN 5480

Cod. MT	Mandrino Spindle Spindel	I	RPM	Coppia Max Max Torque Max Drehmoment	Lubrificazione est. Ext. coolant Aussenkuehlung	CHIAVI NON INCLUSE Keys not included Schluessel nicht einbegriffen	
versione dx right version version rechts	ER32	1:1	6000	70Nm	X	CHUB13	CHSTER32
SAU0060132							

SAUTER
VDI 40

MODULO MOTORIZZATO RADIALE ARRETRATO VDI40 DIN 5480 H=85mm
Radial rear-set driven tool VDI40 DIN 5480 H=85mm
Radial angetriebenes Werkzeug zurueckversetzt VDI40 DIN 5480 H=85mm

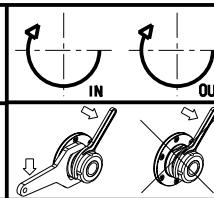

M.T. srl
Via Casino Albini 480
Tel. 0541/956034-957884
Fax 0541/956341
47842 S. GIOVANNI IN M. (RN)
e-mail: mtma@mtmarchetti.com
http://www.mtmarchetti.com

PRODUZIONE MODULI ROTANTI



PAGINA SAU018-3-60

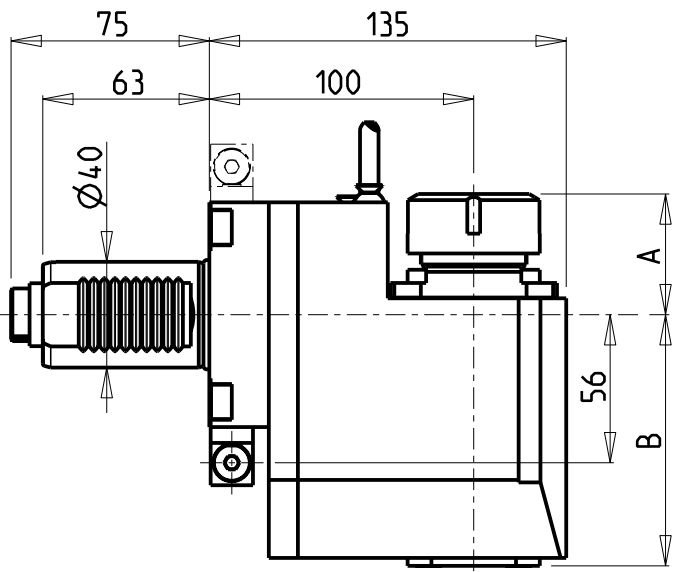

versione dx
right version
version rechts

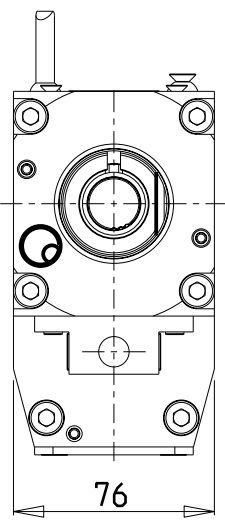

versione sx
left version
version links

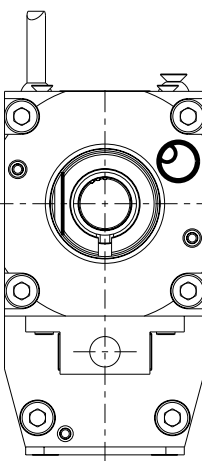

versione universale
universal version
universal version

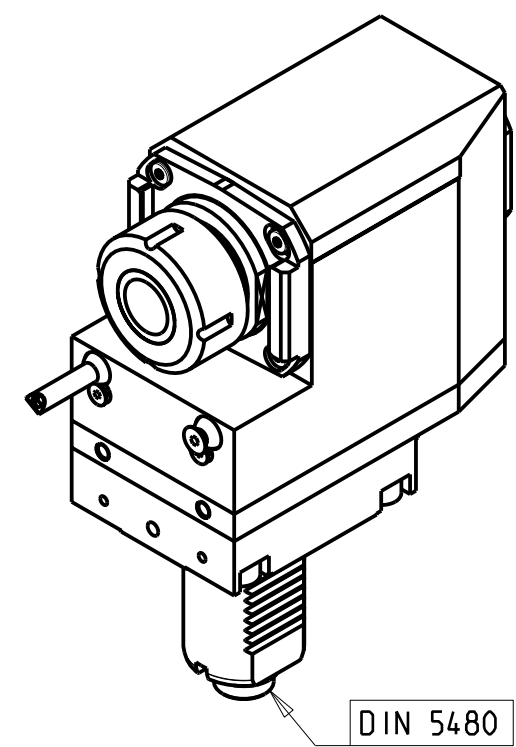
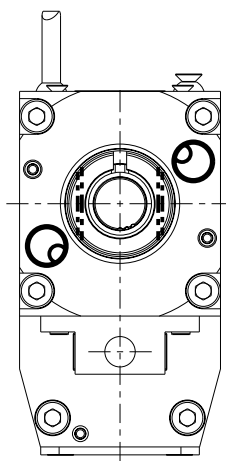

DIN 5480

Cod. MT			Mandrino Spindle Spindel	I	RPM	Coppia Max Max Torque Max Drehmoment	Lubrificazione int. Coolant through Innenkuehlung	Lubrificazione est. Ext. coolant Aussenkuehlung	A	B	CHIAVI NON INCLUDE Keys not included Schluessel nicht einbegriffen	
versione dx right version version rechts	versione sx left version version links	versione universale universal version universal version										
SAU0150125	SAU0151125	SAU0152125	ER25	1:1	6000	70Nm	-	X	42.66	95	CHSTER25	MNZ0410005 ▪
SAU0150225	SAU0151225	SAU0152225	ER25	1:1	6000	70Nm	P=70bar	X	42.66	108.5	CHSTER25	MNZ0410005 ▪
SAU0150132	SAU0151132	SAU0152132	ER32	1:1	6000	70Nm	-	X	45.66	95	CHSTER32	MNZ0410005 ▪
SAU0150232	SAU0151232	SAU0152232	ER32	1:1	6000	70Nm	P=70bar	X	45.66	108.5	CHSTER32	MNZ0410005 ▪

- Chiave inclusa
- Key included
- Schluessel inbegriffen

SAUTER
VDI 40

MODULO MOTORIZZATO RADIALE ARRETRATO VDI40 DIN 5480 H=100mm
Radial rear-set driven tool VDI40 DIN 5480 H=100mm
Radial angetriebenes Werkzeug zurueckversetzt VDI40 DIN 5480 H=100mm

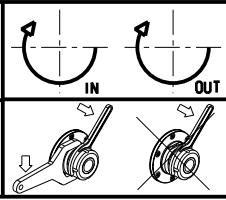

M.T. srl
Via Casino Albini 480
Tel. 0541/956034-957884
Fax 0541/956341
47842 S. GIOVANNI IN M. (RN)
e-mail: mtma@mtmarchetti.com
http://www.mtmarchetti.com

PRODUZIONE MODULI ROTANTI



PAGINA SAU018-3-70

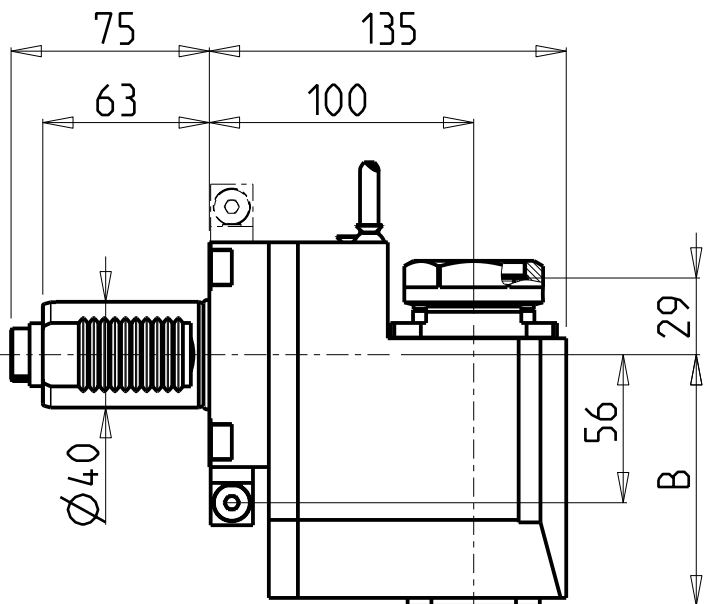

versione dx
right version
version rechts

versione sx
left version
version links

versione universale
universal version
universal version

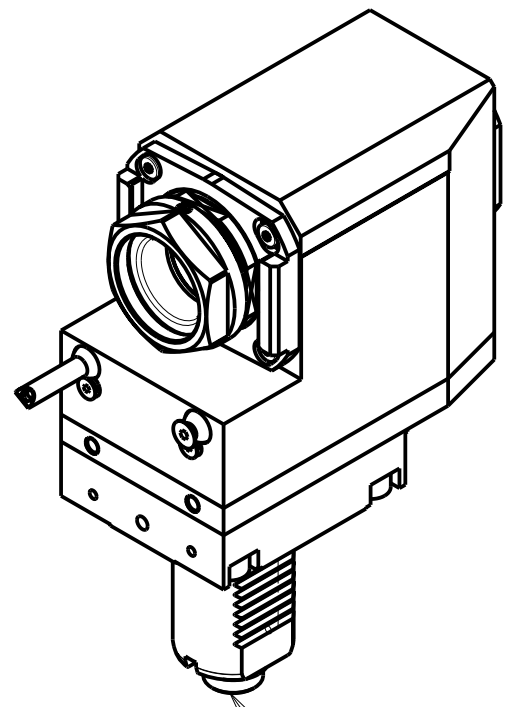
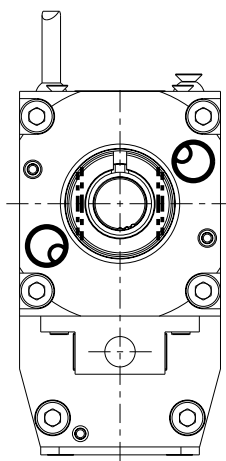
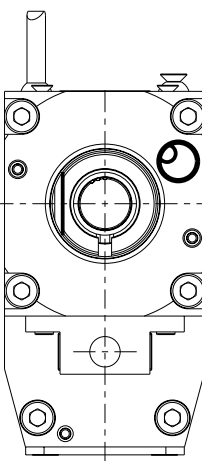
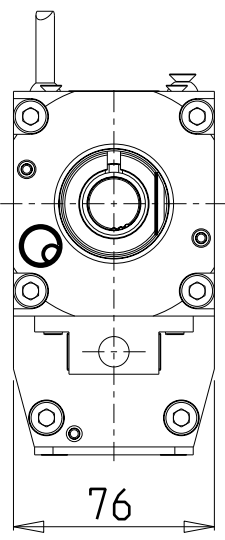

DIN 5480

PER PORTAUTENSILI MODULARI MTSK-40 VEDI PAG. TBL300-1-40
FOR MTSK-40 QUIK CHANGE TOOLHOLDERS CLAMPINGS SEE PAGE TBL300-1-40
FUER MTSK-40 MODULARE WERKZEUGAUFNAHMEN SIEHE SEITE TBL300-1-40

Cod. MT			Mandrino Spindle Spindel	I	RPM	Coppia Max Max Torque Max Drehmoment	Lubrificazione int. Coolant through Innenkuehlung	Lubrificazione est. Ext. coolant Aussenkuehlung	B	CHIAVI NON INCLUDE Keys not included Schluessel nicht einbegriffen	
versione dx right version version rechts	versione sx left version version links	versione universale universal version universal version								CHUB46	MNZ0410005 *
SAU0710140	SAU0711140	SAU0712140	MTSK-40	1:1	6000	70Nm	-	X	95	CHUB46	MNZ0410005 *
SAU0710240	SAU0711240	SAU0712240	MTSK-40	1:1	6000	70Nm	P=70bar	X	108.5	CHUB46	MNZ0410005 *

- Chiave inclusa
- Key included
- Schluessel inbegriffen

SAUTER
VDI 40

MODULO MOTORIZZATO RADIALE ARRETRATO MTSK VDI40 DIN 5480 H=100mm
Radial MTSK rear-set driven tool VDI40 DIN 5480 H=100mm
Radial MTSK angetriebenes Werkzeug zurueckversetzt VDI40 DIN 5480 H=100mm

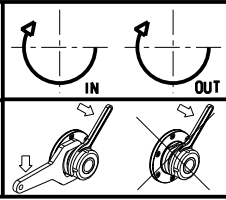

M.T. srl
Via Casino Albini 480
Tel. 0541/956034-957884
Fax 0541/956341
47842 S. GIOVANNI IN M. (RN)
e-mail: mtma@mtmarchetti.com
http://www.mtmarchetti.com

PRODUZIONE MODULI ROTANTI

PAGINA SAU018-3-70-K

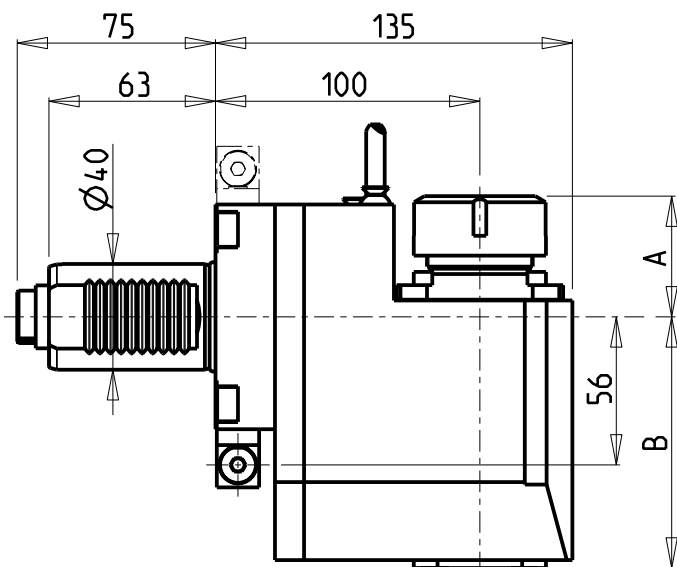

versione dx
right version
version rechts

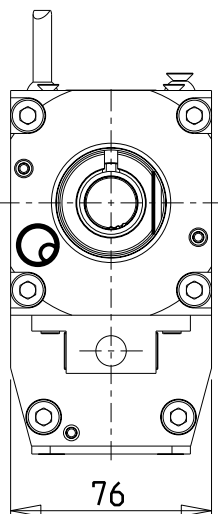

versione sx
left version
version links

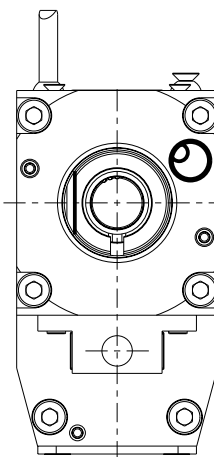

versione universale
universal version
universal version

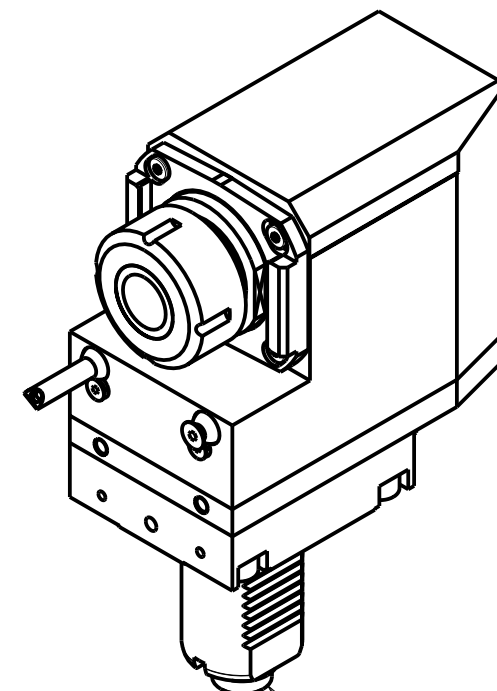
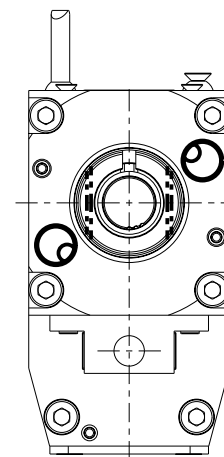

DIN 5480

Cod. MT			Mandrino Spindle Spindel	I	RPM	Coppia Max Max Torque Max Drehmoment	Lubrificazione int. Coolant through Innenkuehlung	Lubrificazione est. Ext. coolant Aussenkuehlung	A	B	CHIAVI NON INCLUSE Keys not included Schluessel nicht einbegriffen	
versione dx right version version rechts	versione sx left version version links	versione universale universal version universal version										
SAU0150325	SAU0151325	SAU0152325	ER25	2:1	3000	90Nm	-	X	42.66	95	CHSTER25	MNZ0410005 ▪
SAU0150425	SAU0151425	SAU0152425	ER25	2:1	3000	90Nm	P=70bar	X	42.66	108.5	CHSTER25	MNZ0410005 ▪
SAU0150332	SAU0151332	SAU0152332	ER32	2:1	3000	90Nm	-	X	45.66	95	CHSTER32	MNZ0410005 ▪
SAU0150432	SAU0151432	SAU0152432	ER32	2:1	3000	90Nm	P=70bar	X	45.66	108.5	CHSTER32	MNZ0410005 ▪

- Chiave inclusa
- Key included
- Schluessel inbegriffen

SAUTER
VDI 40

MODULO MOTORIZZATO RADIALE ARRETRATO RIDOTTO I=2:1 VDI40 DIN 5480
Radial geared-down I=2:1 rear-set driven tool VDI40 DIN 5480
Radial angetriebenes Werkzeug zurueckversetzt untersetzt I=2:1 VDI40 DIN 5480

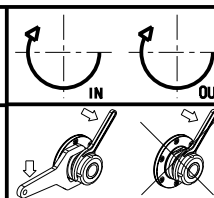

M.T. srl
Via Casino Albini 480
Tel. 0541/956034-957884
Fax 0541/956341
47842 S. GIOVANNI IN M. (RN)
e-mail: mtma@mtmarchetti.com
http://www.mtmarchetti.com

PRODUZIONE MODULI ROTANTI



PAGINA SAU018-3-71

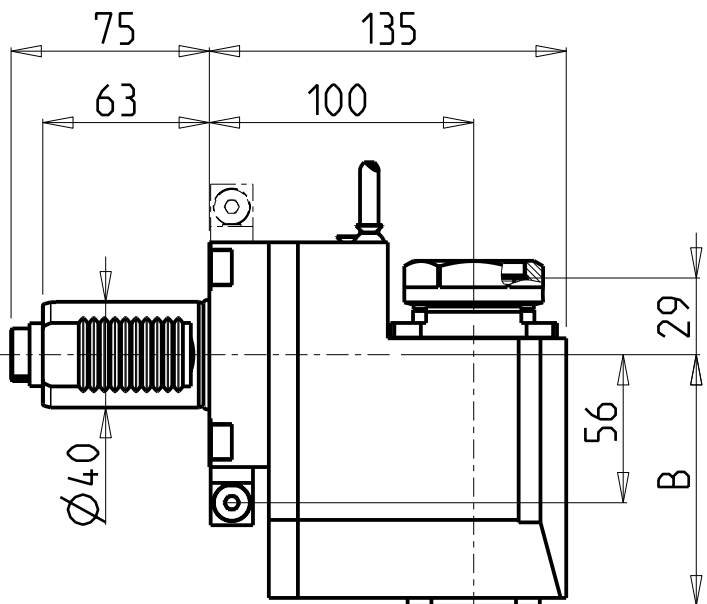

versione dx
right version
version rechts

versione sx
left version
version links

versione universale
universal version
universal version

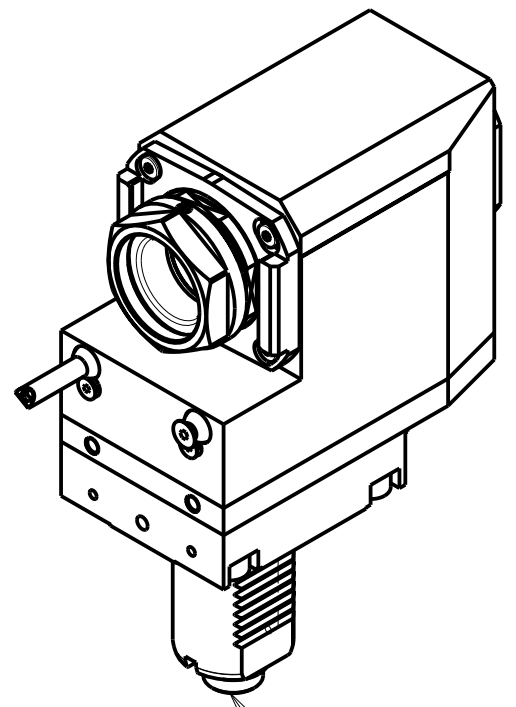
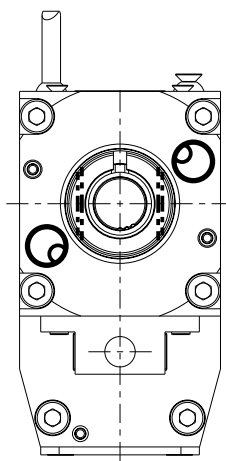
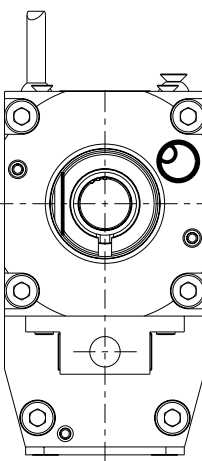
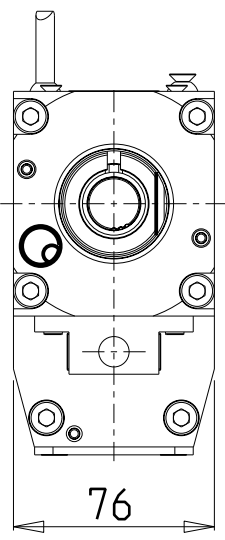

DIN 5480

PER PORTAUTENSILI MODULARI MTSK-40 VEDI PAG. TBL300-1-40
FOR MTSK-40 QUIK CHANGE TOOLHOLDERS CLAMPINGS SEE PAGE TBL300-1-40
FUER MTSK-40 MODULARE WERKZEUGAUFNAHMEN SIEHE SEITE TBL300-1-40

Cod. MT			Mandrino Spindle Spindel	I	RPM	Coppia Max Max Torque Max Drehmoment	Lubrificazione int. Coolant through Innenkuehlung	Lubrificazione est. Ext. coolant Aussenkuehlung	B	CHIAVI NON INCLUDE Keys not included Schluessel nicht einbegriffen	
versione dx right version version rechts	versione sx left version version links	versione universale universal version universal version								CHUB46	MNZ0410005 *
SAU0710340	SAU0711340	SAU0712340	MTSK-40	2:1	3000	90Nm	-	X	95	CHUB46	MNZ0410005 *
SAU0710440	SAU0711440	SAU0712440	MTSK-40	2:1	3000	90Nm	P=70bar	X	108.5	CHUB46	MNZ0410005 *

- Chiave inclusa
- Key included
- Schluessel inbegriffen

SAUTER
VDI 40

MODULO MOTORIZZATO RADIALE ARRETRATO MTSK RIDOTTO I=2:1 VDI40 DIN 5480
Radial MTSK geared-down I=2:1 rear-set driven tool VDI40 DIN 5480
Radial MTSK angetriebenes Werkzeug zurueckversetzt untersetzt I=2:1 VDI40 DIN 5480

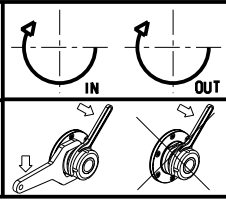

M.T. srl
Via Casino Albini 480
Tel. 0541/956034-957884
Fax 0541/956341
47842 S. GIOVANNI IN M. (RN)
e-mail: mtma@mtmarchetti.com
http://www.mtmarchetti.com

PRODUZIONE MODULI ROTANTI

PAGINA SAU018-3-71-K

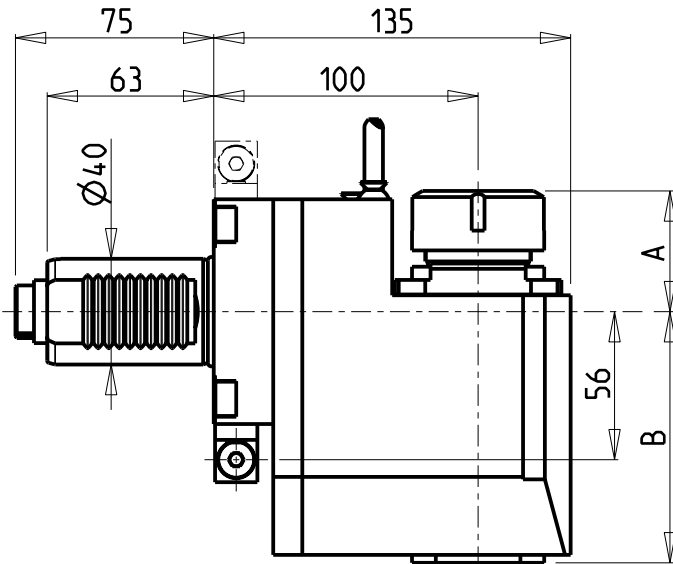

versione dx
right version
version rechts

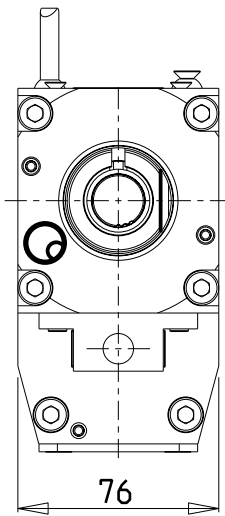

versione sx
left version
version links

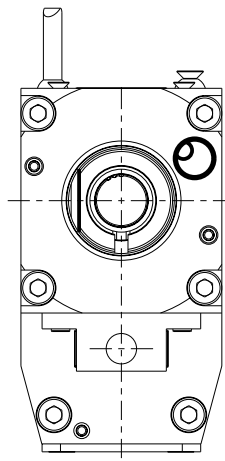

versione universale
universal version
universal version

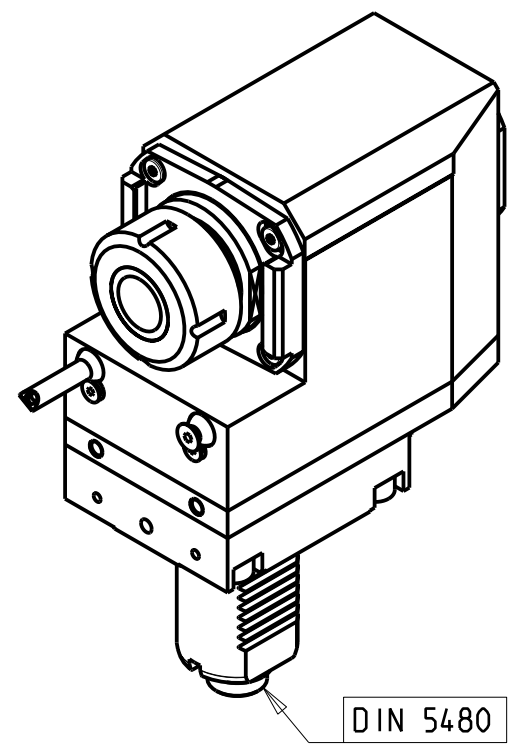
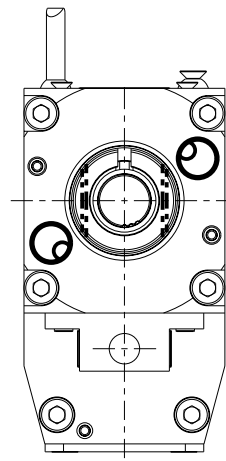

DIN 5480

Cod. MT			Mandrino Spindle Spindel	I	RPM	Coppia Max Max Torque Max Drehmoment	Lubrificazione int. Coolant through Innenkuehlung	Lubrificazione est. Ext. coolant Aussenkuehlung	A	B	CHIAVI NON INCLUDE Keys not included Schluessel nicht einbegriffen	
versione dx right version version rechts	versione sx left version version links	versione universale universal version universal version										
SAU0150525	SAU0151525	SAU0152525	ER25	1:2	12000	40Nm	-	X	42.66	95	CHSTER25	MNZ0410005 ▪
SAU0150625	SAU0151625	SAU0152625	ER25	1:2	12000	40Nm	P=70bar	X	42.66	108.5	CHSTER25	MNZ0410005 ▪
SAU0150532	SAU0151532	SAU0152532	ER32	1:2	12000	40Nm	-	X	45.66	95	CHSTER32	MNZ0410005 ▪
SAU0150632	SAU0151632	SAU0152632	ER32	1:2	12000	40Nm	P=70bar	X	45.66	108.5	CHSTER32	MNZ0410005 ▪

- Chiave inclusa
- Key included
- Schluessel inbegriffen

SAUTER
VDI 40

MODULO MOTORIZZATO RADIALE ARRETRATO MOLTIPLICATO I=1:2 VDI40 DIN 5480
Radial geared-up I=1:2 rear-set driven tool VDI40 DIN 5480
Radial angetriebenes Werkzeug zurueckversetzt uebersetzt I=1:2 VDI40 DIN 5480

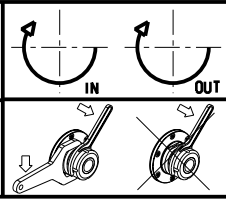

M.T. srl
Via Casino Albini 480
Tel. 0541/956034-957884
Fax 0541/956341
47842 S. GIOVANNI IN M. (RN)
e-mail: mtma@mtmarchetti.com
http://www.mtmarchetti.com

PRODUZIONE MODULI ROTANTI



PAGINA SAU018-3-72

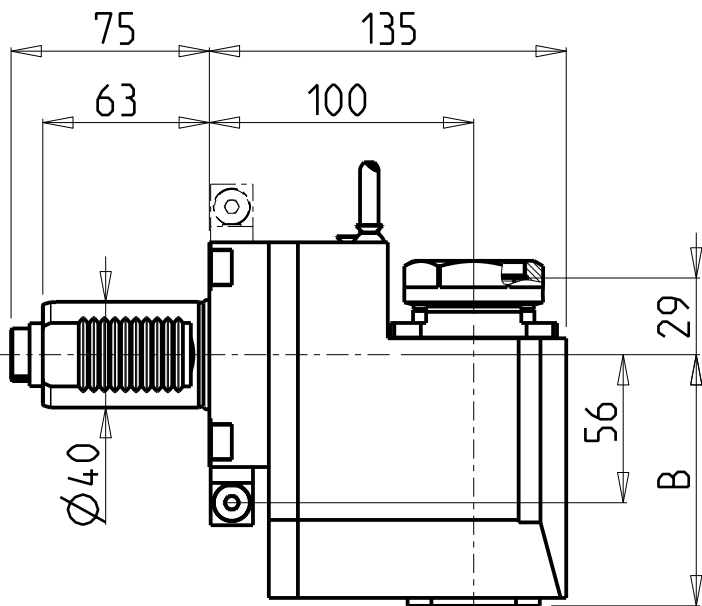

versione dx
right version
version rechts

versione sx
left version
version links

versione universale
universal version
universal version

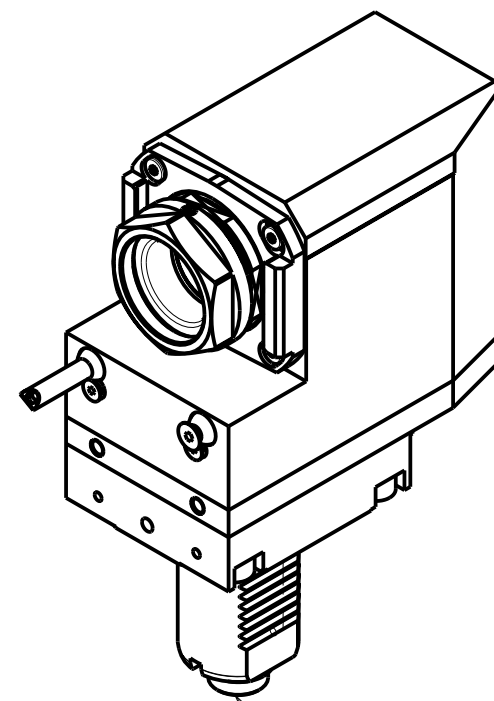
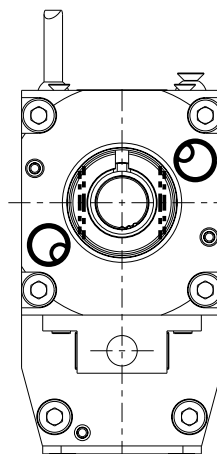
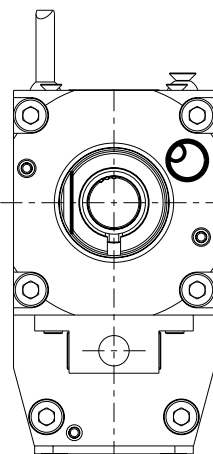
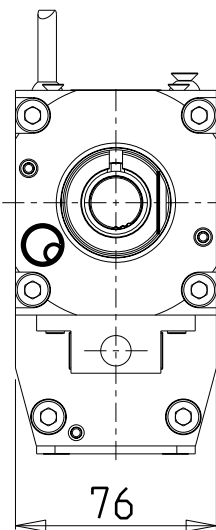

DIN 5480

PER PORTAUTENSILI MODULARI MTSK-40 VEDI PAG. TBL300-1-40
FOR MTSK-40 QUICK CHANGE TOOLHOLDERS CLAMPINGS SEE PAGE TBL300-1-40
FUER MTSK-40 MODULARE WERKZEUGAUFNAHMEN SIEHE SEITE TBL300-1-40

Cod. MT			Mandrino Spindle Spindel	I	RPM	Coppia Max Max Torque Max Drehmoment	Lubrificazione int. Coolant through Innenkuehlung	Lubrificazione est. Ext. coolant Aussenkuehlung	B	CHIAVI NON INCLUSE Keys not included Schlüssel nicht einbegriffen	
versione dx right version version rechts	versione sx left version version links	versione universale universal version universal version								CHUB46	MNZ04 10005 *
SAU0710540	SAU0711540	SAU0712540	MTSK-40	1:2	12000	40Nm	-	X	95	CHUB46	MNZ04 10005 *
SAU0710640	SAU0711640	SAU0712640	MTSK-40	1:2	12000	40Nm	P=70bar	X	108.5	CHUB46	MNZ04 10005 *

- Chiave inclusa
- Key included
- Schlüssel inbegriffen

SAUTER
VDI 40

MODULO MOTORIZZATO RADIALE ARRETRATO MTSK MOLTIPLICATO I=1:2 VDI40 DIN 5480
Radial MTSK geared-up I=1:2 rear-set driven tool VDI40 DIN 5480
Radial MTSK angetriebenes Werkzeug zurueckversetzt uebersetzt I=1:2 VDI40 DIN 5480

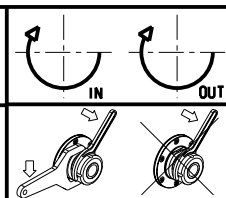

M.T. srl
Via Casino Albini 480
Tel. 0541/956034-957884
Fax 0541/956341
47842 S. GIOVANNI IN M. (RN)
e-mail: mtma@mtmarchetti.com
http://www.mtmarchetti.com

PRODUZIONE MODULI ROTANTI

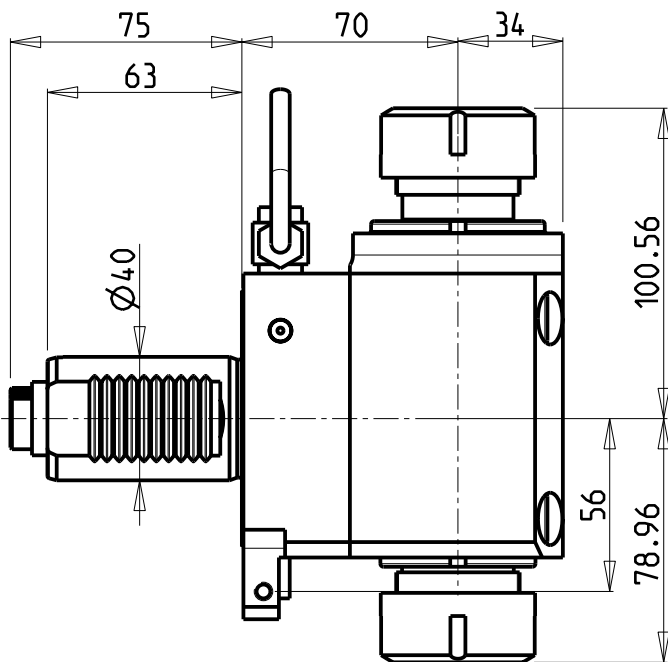
PAGINA SAU018-3-72-K

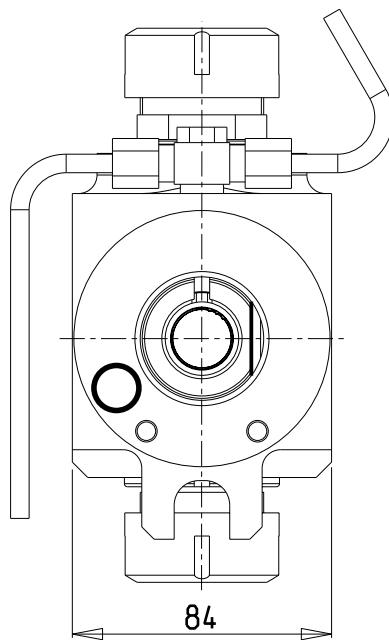

versione dx
right version
version rechts

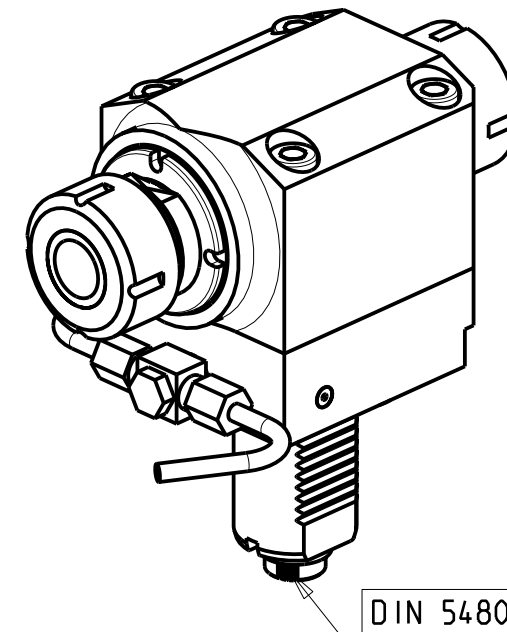
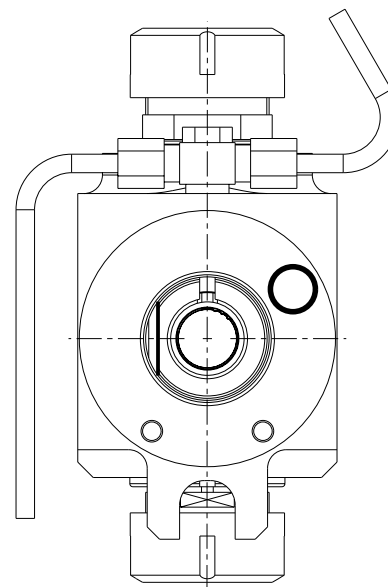

versione sx
left version
version links



ATTENZIONE - ATTENTION - ACHTUNG

- Per lo smontaggio degli utensili utilizzare sempre la chiave di contrasto come indicato nel manuale d'uso.
- For disassembly of the tools use always the contrast key as mentioned in the user instructions.
- Fuer das Abmontieren der Werkzeuge immer den Gegenschlüssel benutzen wie in der Bedienungsanleitung erwäehnt.

Cod. MT		Mandrino Spindle Spindel	I	RPM	Coppia Max Max Torque Max Drehmoment	Lubrificazione est. Ext. coolant Aussehenkuehlung	CHIAVI NON INCLUSE Keys not included Schlüssel nicht einbegriffen	
versione dx right version version rechts	versione sx left version version links						CHUB36	CHSTER32
216SAU_A32_40D00	216SAU_A32_40D10	ER32+ER32	1:1	6000	70Nm	X	CHUB36	CHSTER32

SAUTER
VDI 40

MODULO MOTORIZZATO RADIALE BISPORGENTE VDI40 DIN 5480 H=70mm
Radial opposite face twin driven tool VDI40 DIN 5480 H=70mm
Radial angetriebenes Werkzeug halb vorspringend VDI40 DIN 5480 H=70mm

M.T. srl

Via Casino Albini 480
Tel. 0541/956034-957884
Fax 0541/956341
47842 S. GIOVANNI IN M. (RN)
e-mail: mtma@mtmarchetti.com
http://www.mtmarchetti.com

PRODUZIONE MODULI ROTANTI



PAGINA SAU019-3-00

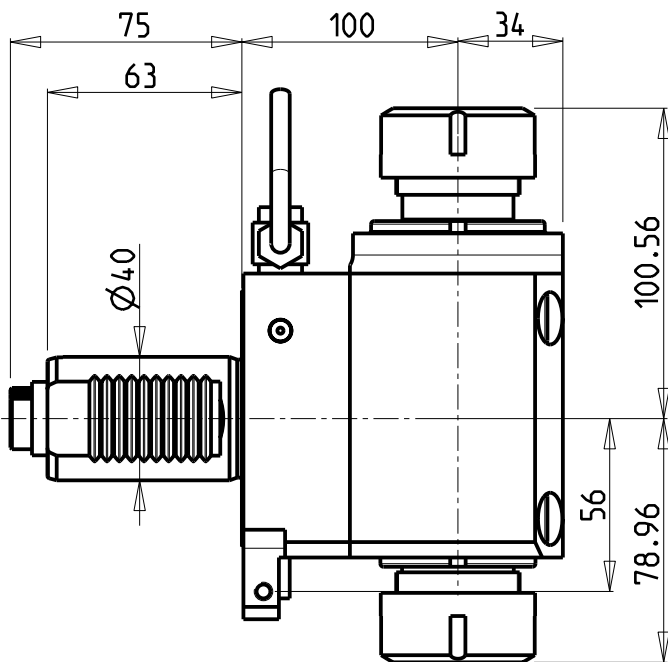

versione dx
right version
version rechts

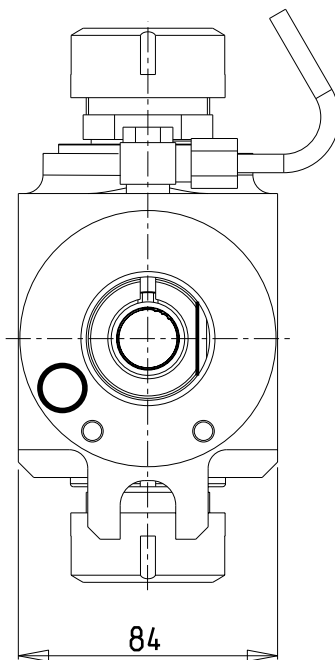

versione sx
left version
version links

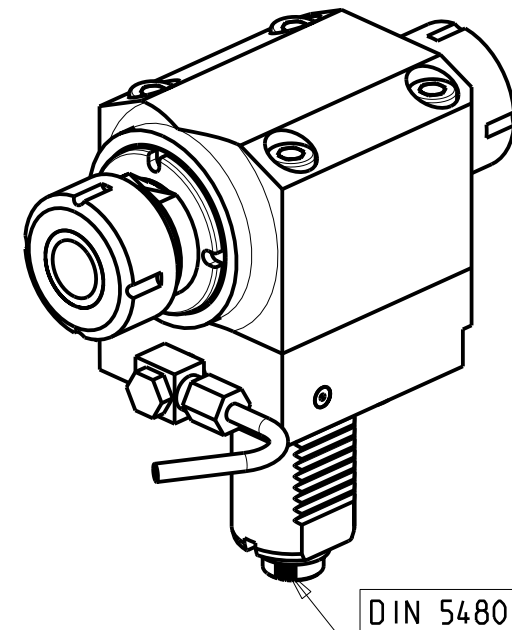
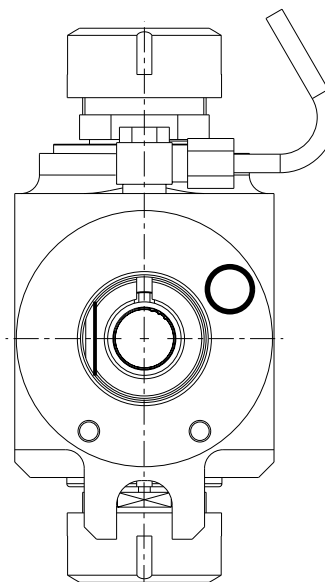

ATTENZIONE - ATTENTION - ACHTUNG

- Per lo smontaggio degli utensili utilizzare sempre la chiave di contrasto come indicato nel manuale d'uso.
- For disassembly of the tools use always the contrast key as mentioned in the user instructions.
- Fuer das Abmontieren der Werkzeuge immer den Gegenschlüssel benutzen wie in der Bedienungsanleitung erwäehnt.

Cod. MT		Mandrino Spindle Spindel	I	RPM	Coppia Max Max Torque Max Drehmoment	Lubrificazione est. Ext. coolant Aussenkuehlung	CHIAVI NON INCLUSE Keys not included Schluesssel nicht einbegriffen	
versione dx right version version rechts	versione sx left version version links						CHUB36	CHSTER32
SAU0030232	-	ER32+ER32	1:1	6000	70Nm	X	CHUB36	CHSTER32

SAUTER
VDI 40

MODULO MOTORIZZATO RADIALE BISPORGENTE VDI40 DIN 5480 H=100mm
Radial opposite face twin driven tool VDI40 DIN 5480 H=100mm
Radial angetriebenes Werkzeug halb vorspringend VDI40 DIN 5480 H=100mm

M.T. srl

Via Casino Albini 480
Tel. 0541/956034-957884
Fax 0541/956341
47842 S. GIOVANNI IN M. (RN)
e-mail: mtma@mtmarchetti.com
http://www.mtmarchetti.com

PRODUZIONE MODULI ROTANTI



PAGINA SAU019-3-10

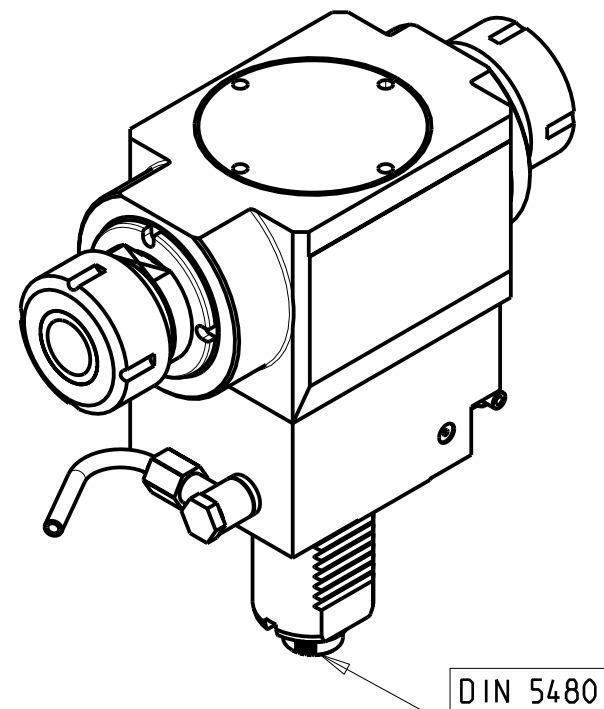
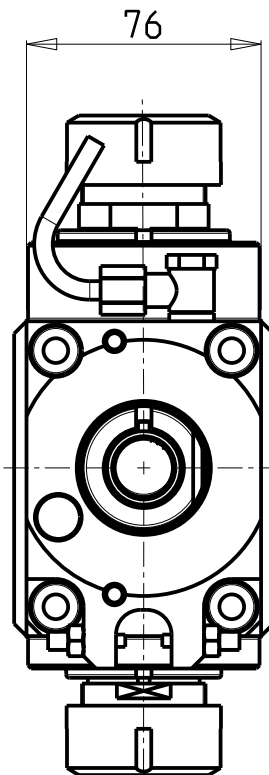
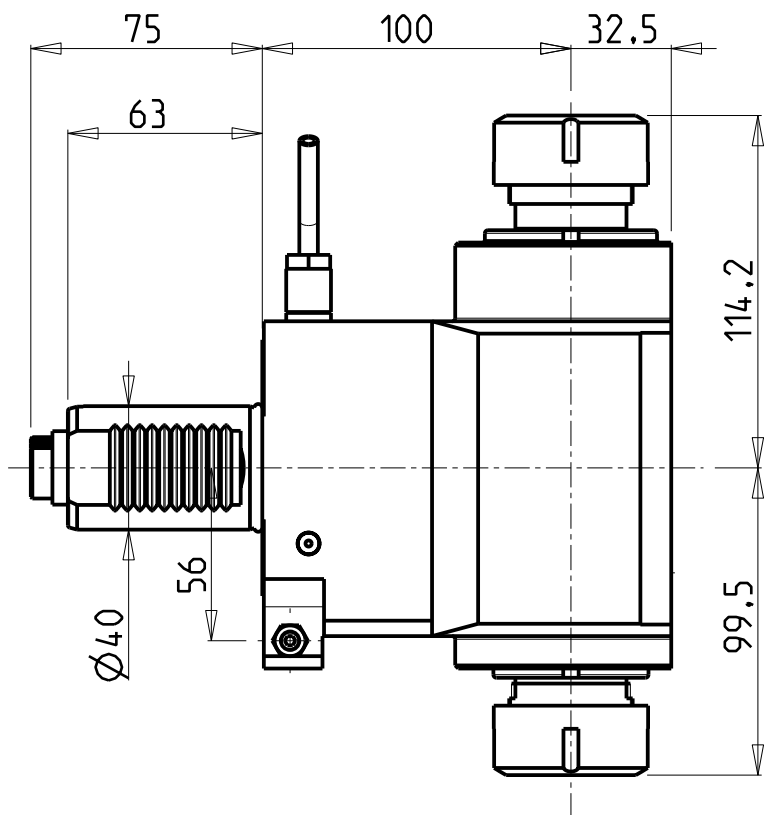

ATTENZIONE - ATTENTION - ACHTUNG

- Per lo smontaggio degli utensili utilizzare sempre la chiave di contrasto come indicato nel manuale d'uso.
- For disassembly of the tools use always the contrast key as mentioned in the user instructions.
- Fuer das Abmontieren der Werkzeuge immer den Gegenschlüssel benutzen wie in der Bedienungsanleitung erwäehnt.

Cod. MT	Mandrino Spindle Spindel	i	RPM	Coppia Max Max Torque Max Drehmoment	Lubrificazione est. Ext. coolant Aussenkuehlung	CHIAVI NON INCLUSE Keys not included Schluessel nicht einbegriffen	
SAU0540232	ER32+ER32	1:2	12000	40Nm	X	CHUB36	CHSTER32

SAUTER
VDI 40

MODULO MOTORIZZATO RADIALE BISPORGENTE MOLTIPLICATO I=1:2 VDI40 DIN 5480
Radial geared-up I=1:2 opposite face twin driven tool VDI40 DIN 5480
Radial angetriebenes Werkzeug halb vorspringend uebersetzt I=1:2 VDI40 DIN 5480

M.T. srl

Via Casino Albini 480
Tel. 0541/956034-957884
Fax 0541/956341
47842 S. GIOVANNI IN M. (RN)
e-mail: mtma@mtmarchetti.com
http://www.mtmarchetti.com

PRODUZIONE MODULI ROTANTI



PAGINA SAU019-3-13

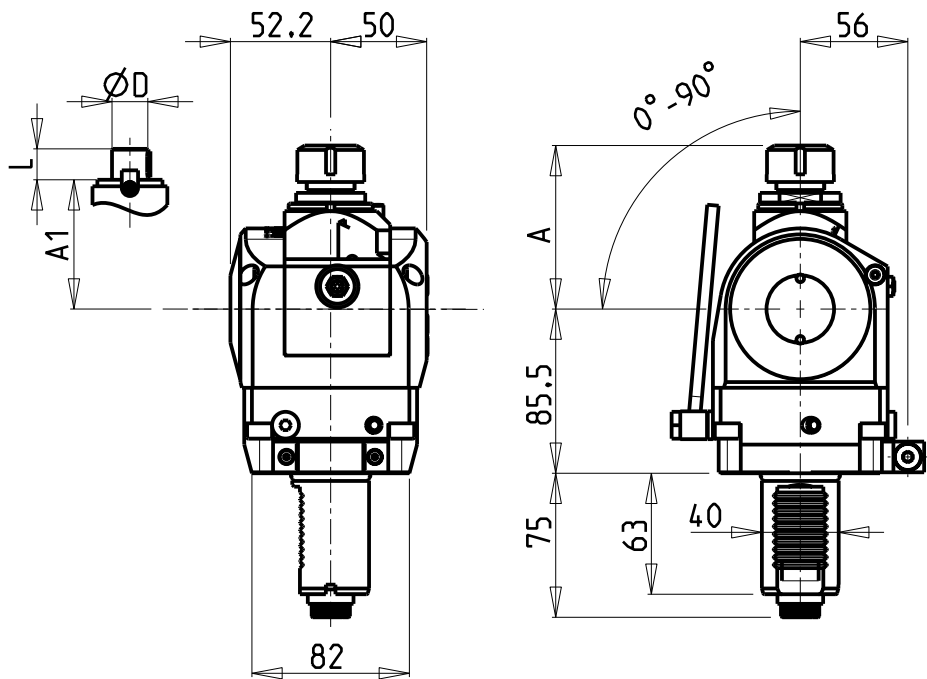

versione dx
right version
version rechts

versione sx
left version
version links

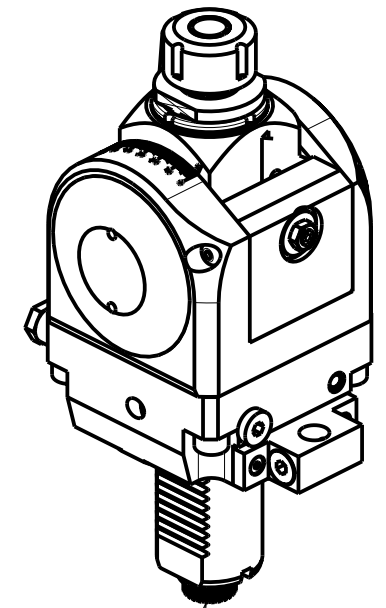
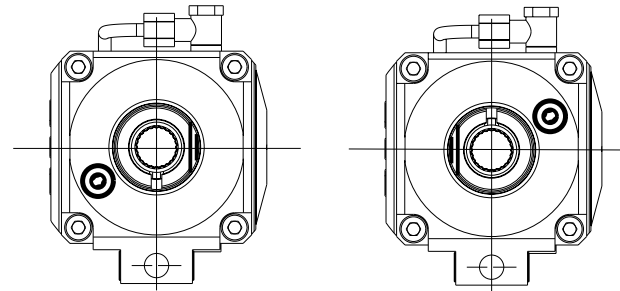

DIN 5480

Cod. MT		Mandrino Spindle Spindel	I	RPM	Coppia Max Max Torque Max Drehmoment	Lubrificazione est. Ext. coolant Aussehenkuehlung	A	A1	D	L	CHIAVI INCLUDE Keys included Schlüssel einbegriffen	
versione dx right version version rechts	versione sx left version version links										CHUB36	CHSTER
SAU0790120	SAU0791120	ER20	1:1	6000	40Nm	X	85.16	-	-	-	CHUB36	CHSTER20
SAU0790125	SAU0791125	ER25	1:1	6000	40Nm	X	86.16	-	-	-	CHUB36	CHSTER25
SAU0790516	SAU0791516	Ø16x17	1:1	6000	40Nm	X	-	65	16	17	CHUB36	CH_VTCROCE_M08
SAU0790522	SAU0791522	Ø22x19	1:1	6000	40Nm	X	-	66	22	19	CHUB36	CH_VTCROCE_M10
SAU0790519	SAU0791519	Ø3/4"x3/4"	1:1	6000	40Nm	X	-	65	3/4"	3/4"	CHUB36	CH_VTCROCE_M08

SAUTER
VDI 40

MODULO MOTORIZZATO ORIENTABILE 0-90° VDI40 DIN 5480
0-90° adjustable angle driven tool VDI40 DIN 5480
Angetriebenes Werkzeug schwenkbar 0-90° VDI40 DIN 5480

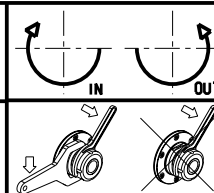

M.T. srl

Via Casino Albini 480
Tel. 0541/956034-957884
Fax 0541/956341
47842 S. GIOVANNI IN M. (RN)
e-mail: mtma@mtmarchetti.com
http://www.mtmarchetti.com

PRODUZIONE MODULI ROTANTI



PAGINA SAU019-3-50

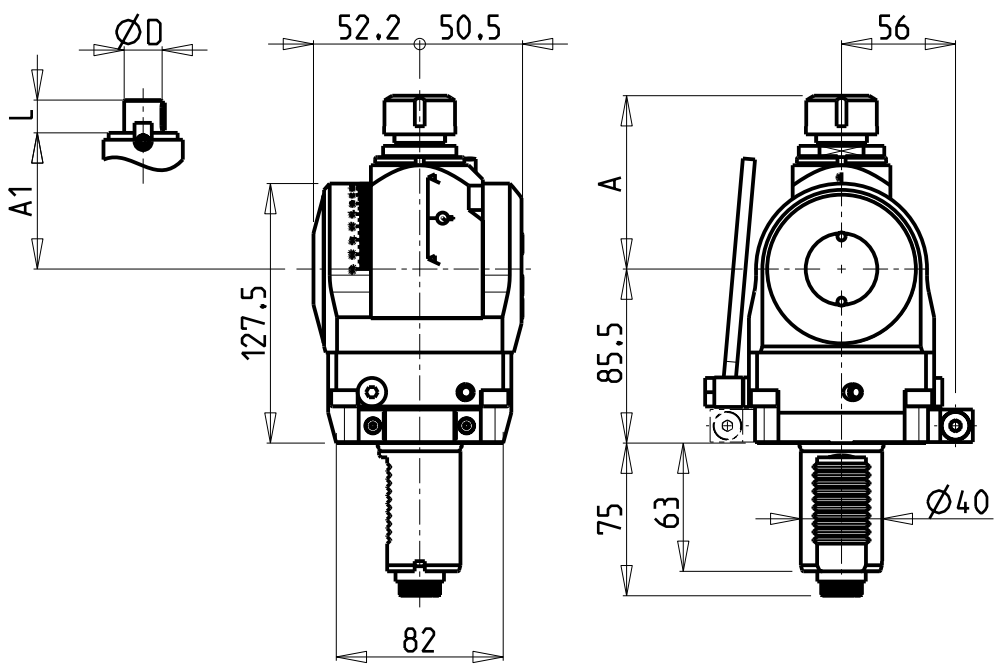

versione dx
right version
version rechts

versione sx
left version
version links

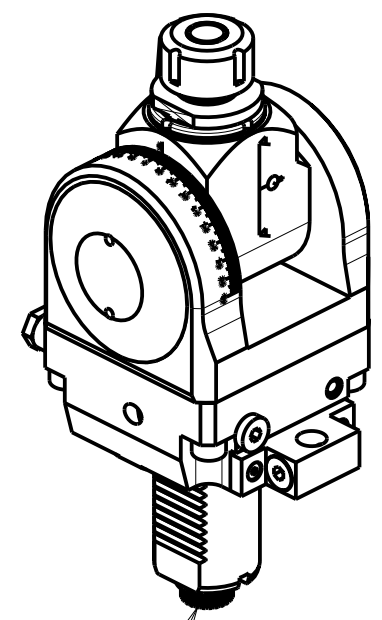
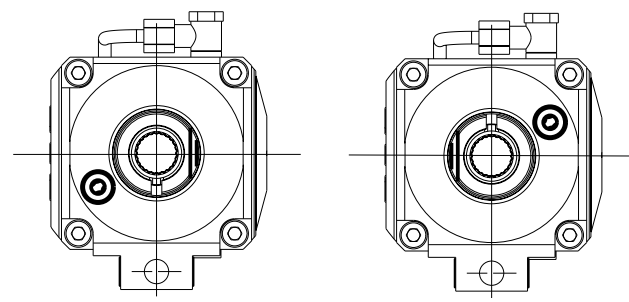

DIN 5480

Cod. MT		Mandrino Spindle Spindel	I	RPM	Coppia Max Max Torque Max Drehmoment	Lubrificazione est. Ext. coolant Aussehenkuehlung	A	A1	D	L	CHIAVI INCLUDE Keys included Schlüssel einbegriffen	
versione dx right version version rechts	versione sx left version version links											
SAU0860120	SAU0861120	ER20	1:1	6000	40Nm	X	85.16	-	-	-	CHUB36	CHSTER20
SAU0860125	SAU0861125	ER25	1:1	6000	40Nm	X	86.16	-	-	-	CHUB36	CHSTER25
SAU0860516	SAU0861516	Ø16x17	1:1	6000	40Nm	X	-	65	16	17	CHUB36	CH_VTCROCE_M08
SAU0860522	SAU0861522	Ø22x19	1:1	6000	40Nm	X	-	66	22	19	CHUB36	CH_VTCROCE_M10
SAU0860519	SAU0861519	Ø3/4"x3/4"	1:1	6000	40Nm	X	-	65	3/4"	3/4"	CHUB36	CH_VTCROCE_M08

SAUTER
VDI 40

MODULO MOTORIZZATO ORIENTABILE ±90° VDI40 DIN 5480
±90° adjustable angle driven tool VDI40 DIN 5480
Angetriebenes Werkzeug schwenkbar ±90° VDI40 DIN 5480

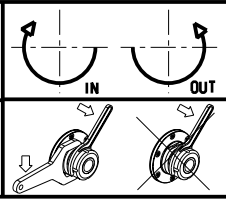

M.T. srl
Via Casino Albini 480
Tel. 0541/956034-957884
Fax 0541/956341
47842 S. GIOVANNI IN M. (RN)
e-mail: mtma@mtmarchetti.com
http://www.mtmarchetti.com

PRODUZIONE MODULI ROTANTI

PAGINA SAU019-3-60

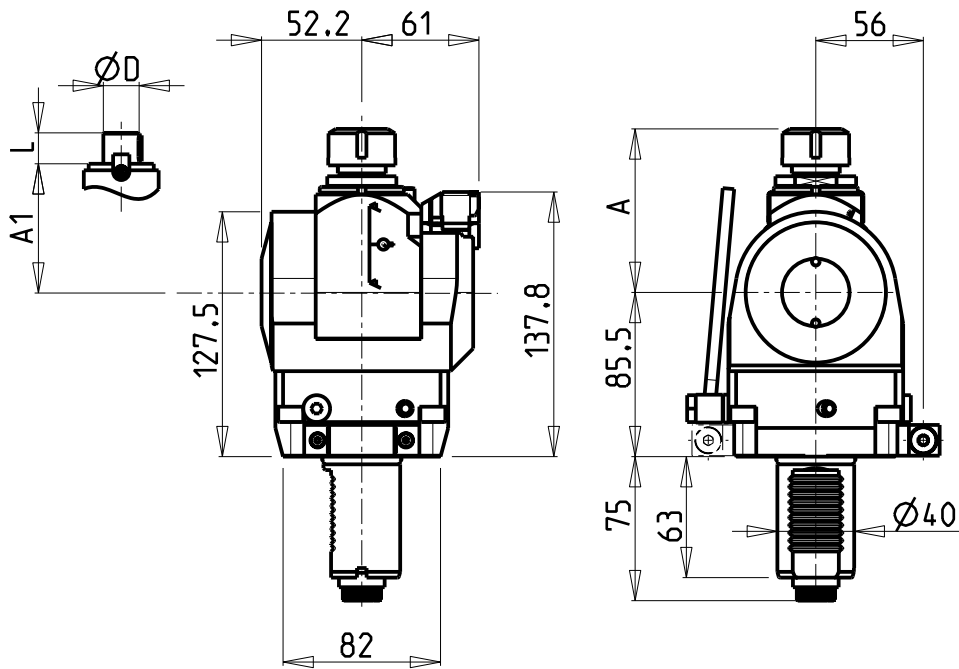

versione dx
right version
version rechts

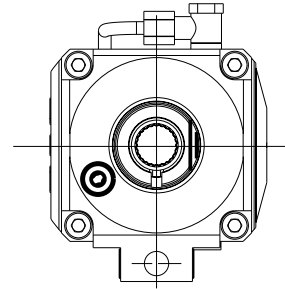

versione sx
left version
version links

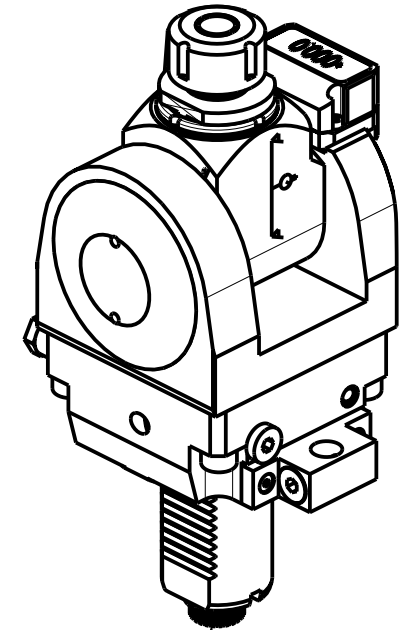
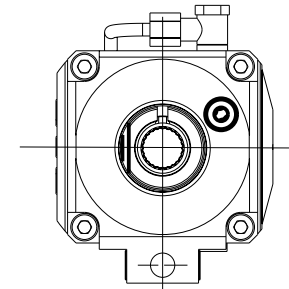

DIN 5480

Cod. MT		Mandrino Spindle Spindel	I	RPM	Coppia Max Max Torque Max Drehmoment	Lubrificazione est. Ext. coolant Aussehenkuehlung	A	A1	D	L	CHIAVI INCLUDE Keys included Schlüssel einbegriffen	
versione dx right version version rechts	versione sx left version version links											
SAU0800120	SAU0801120	ER20	1:1	6000	40Nm	X	85.16	-	-	-	CHUB36	CHSTER20
SAU0800125	SAU0801125	ER25	1:1	6000	40Nm	X	86.16	-	-	-	CHUB36	CHSTER25
SAU0800516	SAU0801516	Ø16x17	1:1	6000	40Nm	X	-	65	16	17	CHUB36	CH_VTCROCE_M08
SAU0800522	SAU0801522	Ø22x19	1:1	6000	40Nm	X	-	66	22	19	CHUB36	CH_VTCROCE_M10
SAU0800519	SAU0801519	Ø3/4"x3/4"	1:1	6000	40Nm	X	-	65	3/4"	3/4"	CHUB36	CH_VTCROCE_M08

SAUTER
VDI 40

MODULO MOTORIZZATO ORIENTABILE ±90° CON NONIO DIGITALE VDI40 DIN 5480
±90° adjustable angle driven tool with digital display VDI40 DIN 5480
Angetriebenes Werkzeug schwenkbar ±90° mit digital display VDI40 DIN 5480

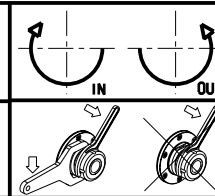

M.T. srl

Via Casino Albini 480
Tel. 0541/956034-957884
Fax 0541/956341
47842 S. GIOVANNI IN M. (RN)
e-mail: mtma@mtmarchetti.com
http://www.mtmarchetti.com

PRODUZIONE MODULI ROTANTI



PAGINA SAU019-3-61

ATTENZIONE - ATTENTION - ACHTUNG

- Per lo smontaggio degli utensili utilizzare sempre la chiave di contrasto come indicato nel manuale d'uso.
- For disassembly of the tools use always the contrast key as mentioned in the user instructions.
- Fuer das Abmontieren der Werkzeuge immer den Gegenschlüssel benutzen wie in der Bedienungsanleitung erwaeht.

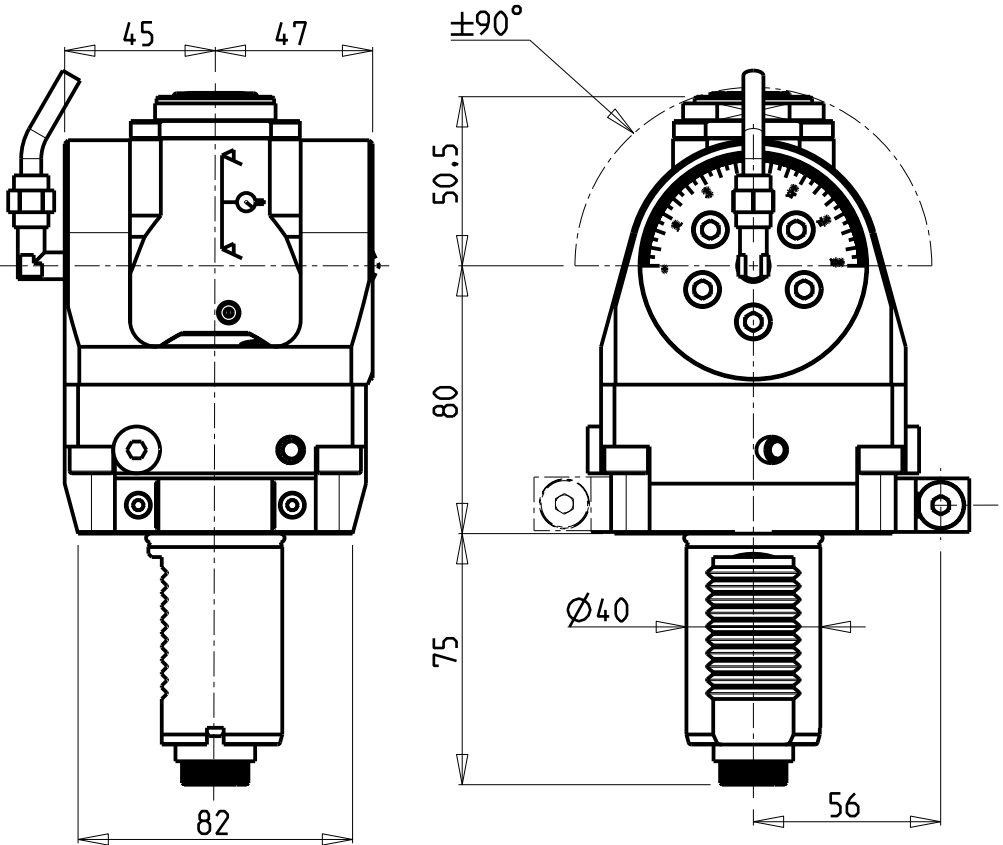

versione dx
right version
version rechts

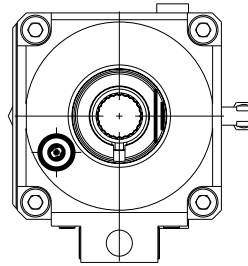

versione sx
left version
version links

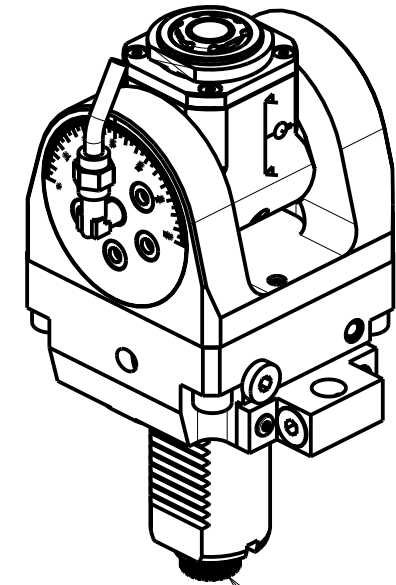
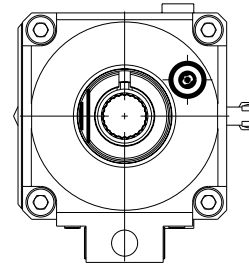

DIN 5480

Cod. MT		Mandrino Spindle Spindel	I	RPM	Coppia Max Max Torque Max Drehmoment	Lubrificazione int. Coolant through Innenkuehlung	Lubrificazione est. Ext. coolant Aussenkuehlung	CHIAVI INCLUSE Keys included Schluessel inbegriffen		
versione dx right version version rechts	versione sx left version version links							CHUB36	CHUB22	CHTAER20ZC
SAU0750120	SAU0751120	ERA20	1:1	6000	30Nm	-	X	CHUB36	CHUB22	CHTAER20ZC
SAU0750220	SAU0751220	ERA20	1:1	6000	30Nm	P=70bar	X	CHUB36	CHUB22	CHTAER20ZC

SAUTER
VDI 40

MODULO MOTORIZZATO ORIENTABILE ±90° VDI40 DIN 5480
±90° adjustable angle driven tool VDI40 DIN 5480
Angetriebenes Werkzeug schwenkbar ±90° VDI40 DIN 5480

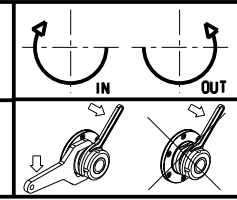

M.T. srl
Via Casino Albini 480
Tel. 0541/956034-957884
Fax 0541/956341
47842 S. GIOVANNI IN M. (RN)
e-mail: mtma@mtmarchetti.com
http://www.mtmarchetti.com

PRODUZIONE MODULI ROTANTI



PAGINA SAU019-3-70

ATTENZIONE - ATTENTION - ACHTUNG

- Per lo smontaggio degli utensili utilizzare sempre la chiave di contrasto come indicato nel manuale d'uso.
- For disassembly of the tools use always the contrast key as mentioned in the user instructions.
- Fuer das Abmontieren der Werkzeuge immer den Gegenschlüssel benutzen wie in der Bedienungsanleitung erwaeht.

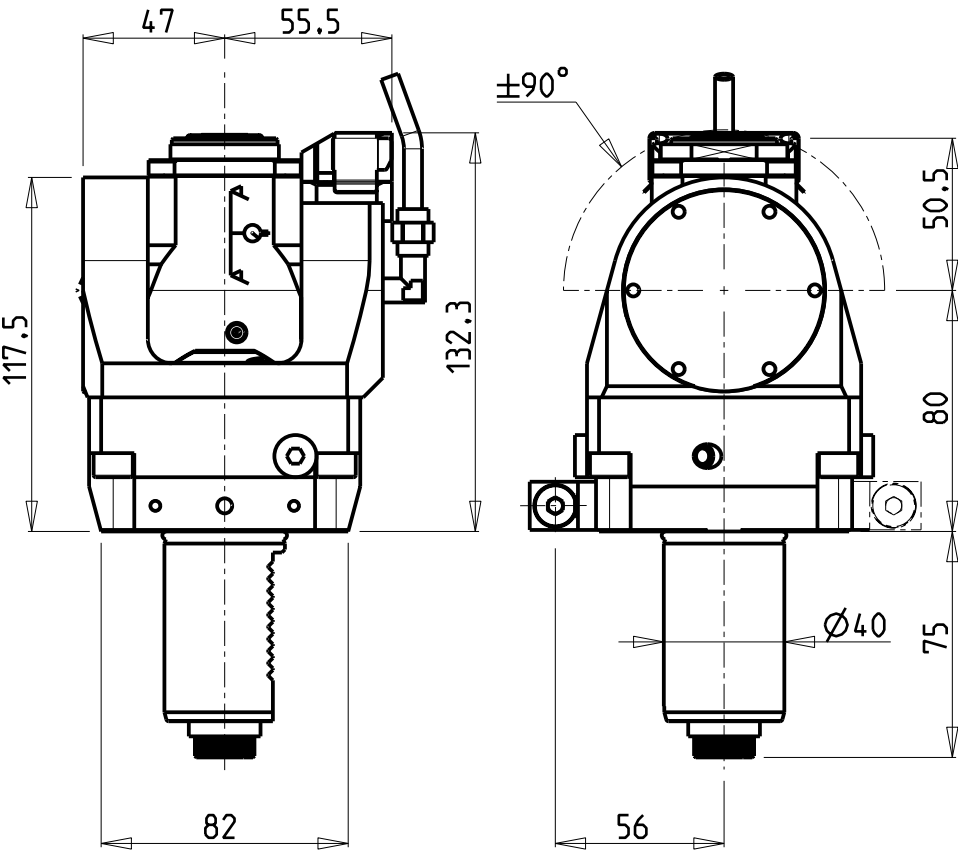

versione dx
right version
version rechts

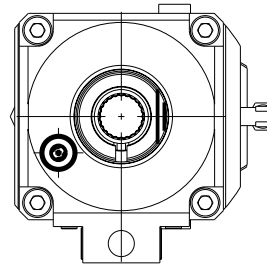

versione sx
left version
version links

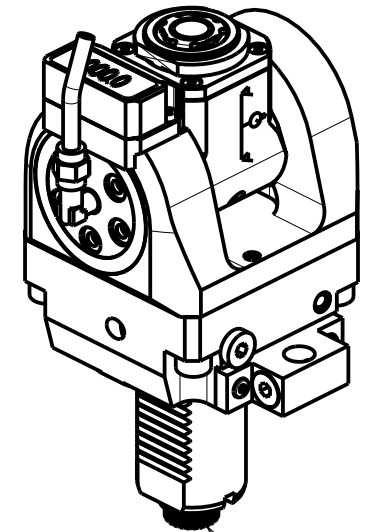
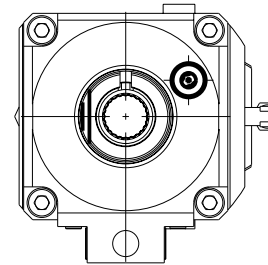

DIN 5480

Cod. MT		Mandrino Spindel Spindel	I	RPM	Coppia Max Max Torque Max Drehmoment	Lubrificazione int. Coolant through Innenkuehlung	Lubrificazione est. Ext. coolant Aussenkuehlung	CHIAVI INCLUSE Keys included Schlüssel inbegriffen		
versione dx right version version rechts	versione sx left version version links							CHUB36	CHUB22	CHTAER20ZC
SAU0755120	SAU0756120	ERA20	1:1	6000	30Nm	-	X	CHUB36	CHUB22	CHTAER20ZC
SAU0755220	SAU0756220	ERA20	1:1	6000	30Nm	P=70bar	X	CHUB36	CHUB22	CHTAER20ZC

SAUTER
VDI 40

MODULO MOTORIZZATO ORIENTABILE ±90° CON NONIO DIGITALE VDI40 DIN 5480
±90° adjustable angle driven tool with digital display VDI40 DIN 5480
Angetriebenes Werkzeug schwenkbar ±90° mit digital display VDI40 DIN 5480

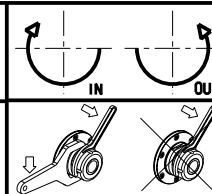

M.T. srl

Via Casino Albini 480
Tel. 0541/956034-957884
Fax 0541/956341
47842 S. GIOVANNI IN M. (RN)
e-mail: mtma@mtmarchetti.com
http://www.mtmarchetti.com

PRODUZIONE MODULI ROTANTI



PAGINA SAU019-3-71

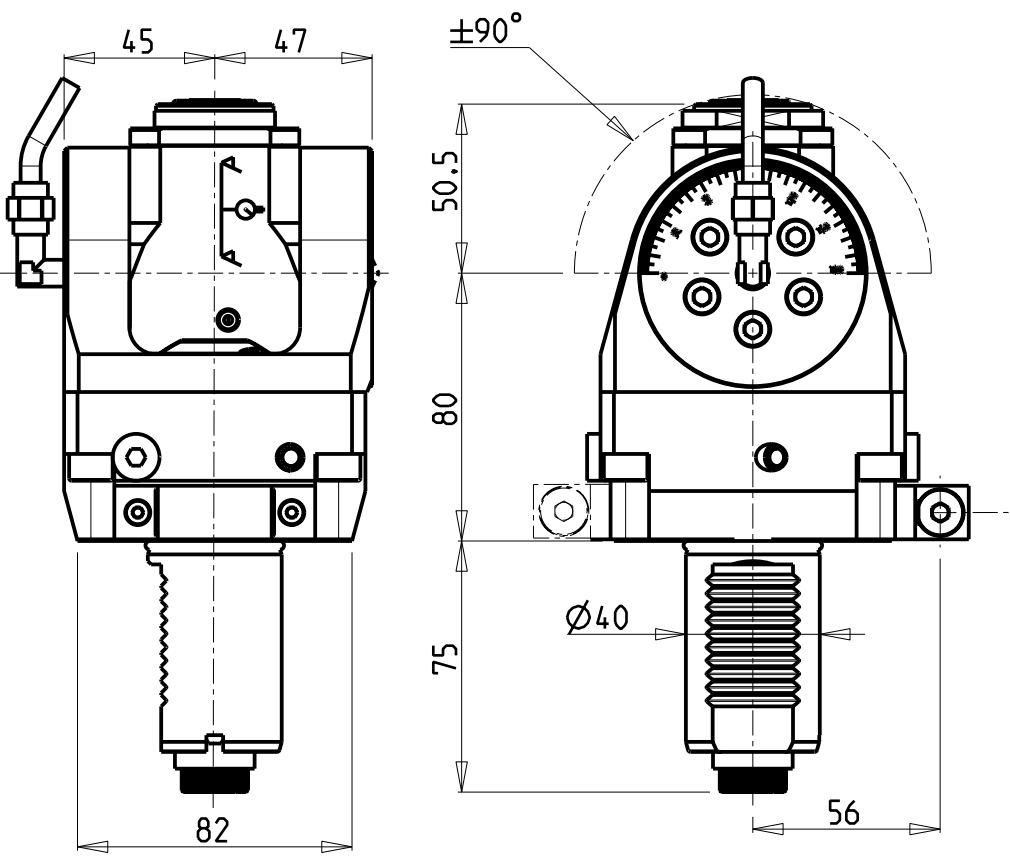

versione dx
right version
version rechts

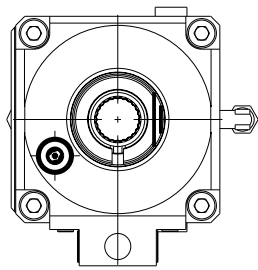

versione sx
left version
version links

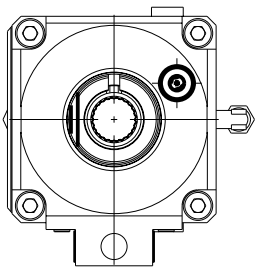

ATTENZIONE - ATTENTION - ACHTUNG

- Per lo smontaggio degli utensili utilizzare sempre la chiave di contrasto come indicato nel manuale d'uso.
- For disassembly of the tools use always the contrast key as mentioned in the user instructions.
- Fuer das Abmontieren der Werkzeuge immer den Gegenschlüssel benutzen wie in der Bedienungsanleitung erwäehnt.

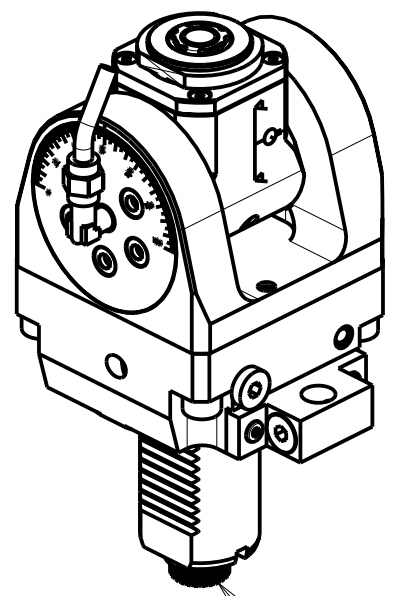

DIN 5480

Cod. MT		Mandrino Spindle Spindel	i	RPM	Coppia Max Max Torque Max Drehmoment	Lubrificazione int. Coolant through Innenkuehlung	Lubrificazione est. Ext. coolant Aussenkuehlung	CHIAVI INCLUSE Keys included Schluessel inbegriffen		
versione dx right version version rechts	versione sx left version version links									
SAU0750316	SAU0751316	ERA16	1:2	12000	8Nm	-	X	CHUB19_SP3	CHUB32	CHTAER16ZC
SAU0750416	SAU0751416	ERA16	1:2	12000	8Nm	P=70bar	X	CHUB19_SP3	CHUB32	CHTAER16ZC

SAUTER
VDI 40

MODULO MOTORIZZATO ORIENTABILE ±90° MOLTIPLICATO i=1:2 VDI40 DIN 5480
±90° adjustable angle driven tool geared-up i=1:2 VDI40 DIN 5480
Angetriebenes Werkzeug schwenkbar ±90° uebersetzt i=1:2 VDI40 DIN 5480

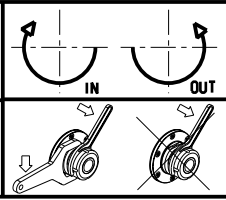

M.T. srl

Via Casino Albini 480
Tel. 0541/956034-957884
Fax 0541/956341
47842 S. GIOVANNI IN M. (RN)
e-mail: mtma@mtmarchetti.com
http://www.mtmarchetti.com

PRODUZIONE MODULI ROTANTI



PAGINA SAU019-3-80

ATTENZIONE - ATTENTION - ACHTUNG

- Per lo smontaggio degli utensili utilizzare sempre la chiave di contrasto come indicato nel manuale d'uso.
- For disassembly of the tools use always the contrast key as mentioned in the user instructions.
- Fuer das Abmontieren der Werkzeuge immer den Gegenschlüssel benutzen wie in der Bedienungsanleitung erwaeht.

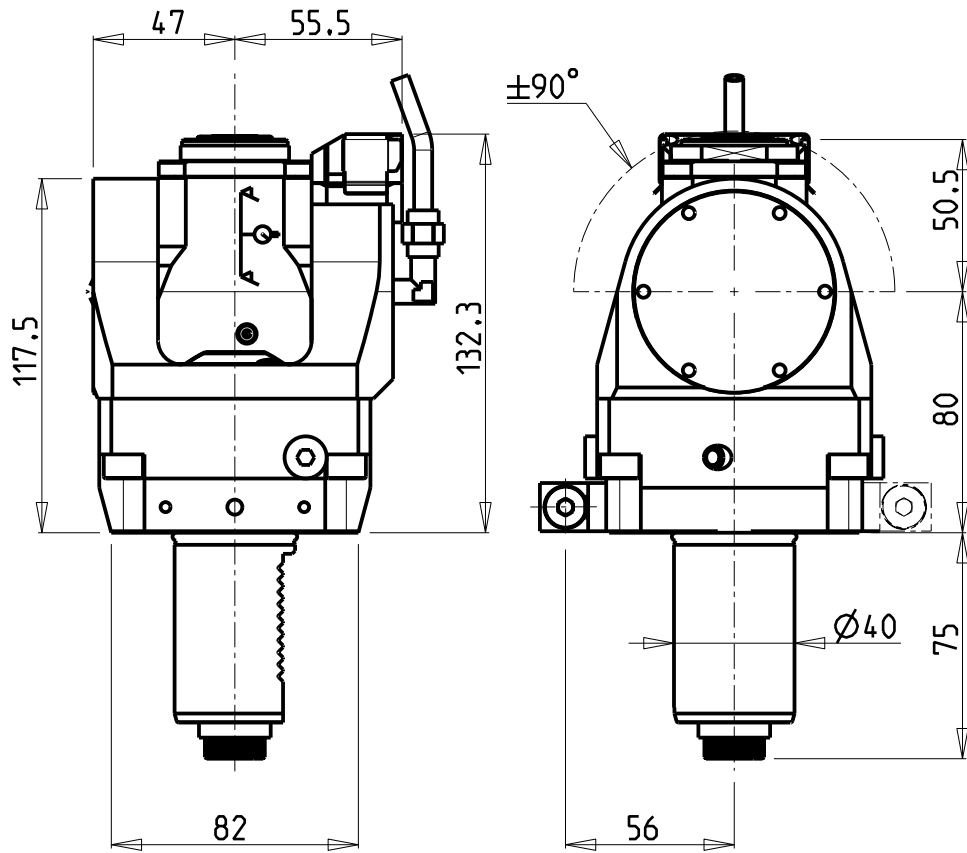

versione dx
right version
version rechts

versione sx
left version
version links

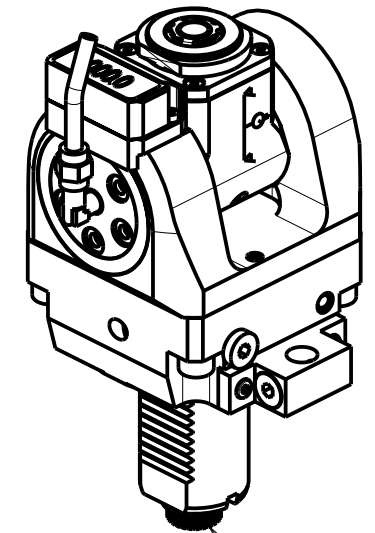
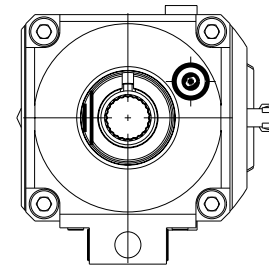
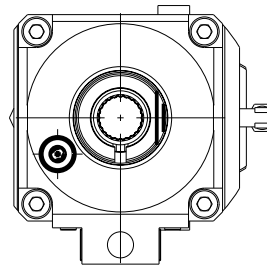

DIN 5480

Cod. MT		Mandrino Spindle Spindel	I	RPM	Coppia Max Max Torque Max Drehmoment	Lubrificazione int. Coolant through Innenkuehlung	Lubrificazione est. Ext. coolant Aussenkuehlung	CHIAVI INCLUSE Keys included Schlüssel inbegriffen		
versione dx right version version rechts	versione sx left version version links									
SAU0755316	SAU0756316	ERA16	1:2	12000	8Nm	-	X	CHUB19_SP3	CHUB32	CHTAER16ZC
SAU0755416	SAU0756416	ERA16	1:2	12000	8Nm	P=70bar	X	CHUB19_SP3	CHUB32	CHTAER16ZC

SAUTER
VDI 40

MODULO MOTORIZZATO ORIENTABILE ±90° Moltiplicato I=1:2 con nonio digitale VDI40 DIN 5480
±90° adjustable angle driven tool geared-up I=1:2 with digital display VDI40 DIN 5480
Angetriebenes Werkzeug schwenkbar ±90° uebersetzt I=1:2 mit digital display VDI40 DIN 5480

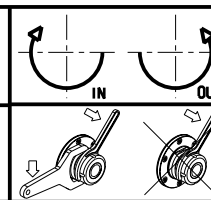

M.T. srl

Via Casino Albini 480
Tel. 0541/956034-957884
Fax 0541/956341
47842 S. GIOVANNI IN M. (RN)
e-mail: mtma@mtmarchetti.com
http://www.mtmarchetti.com

PRODUZIONE MODULI ROTANTI



PAGINA SAU019-3-81

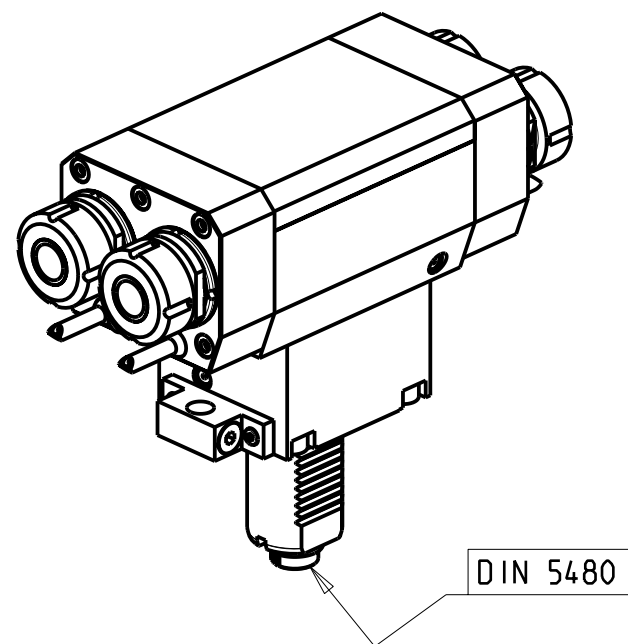
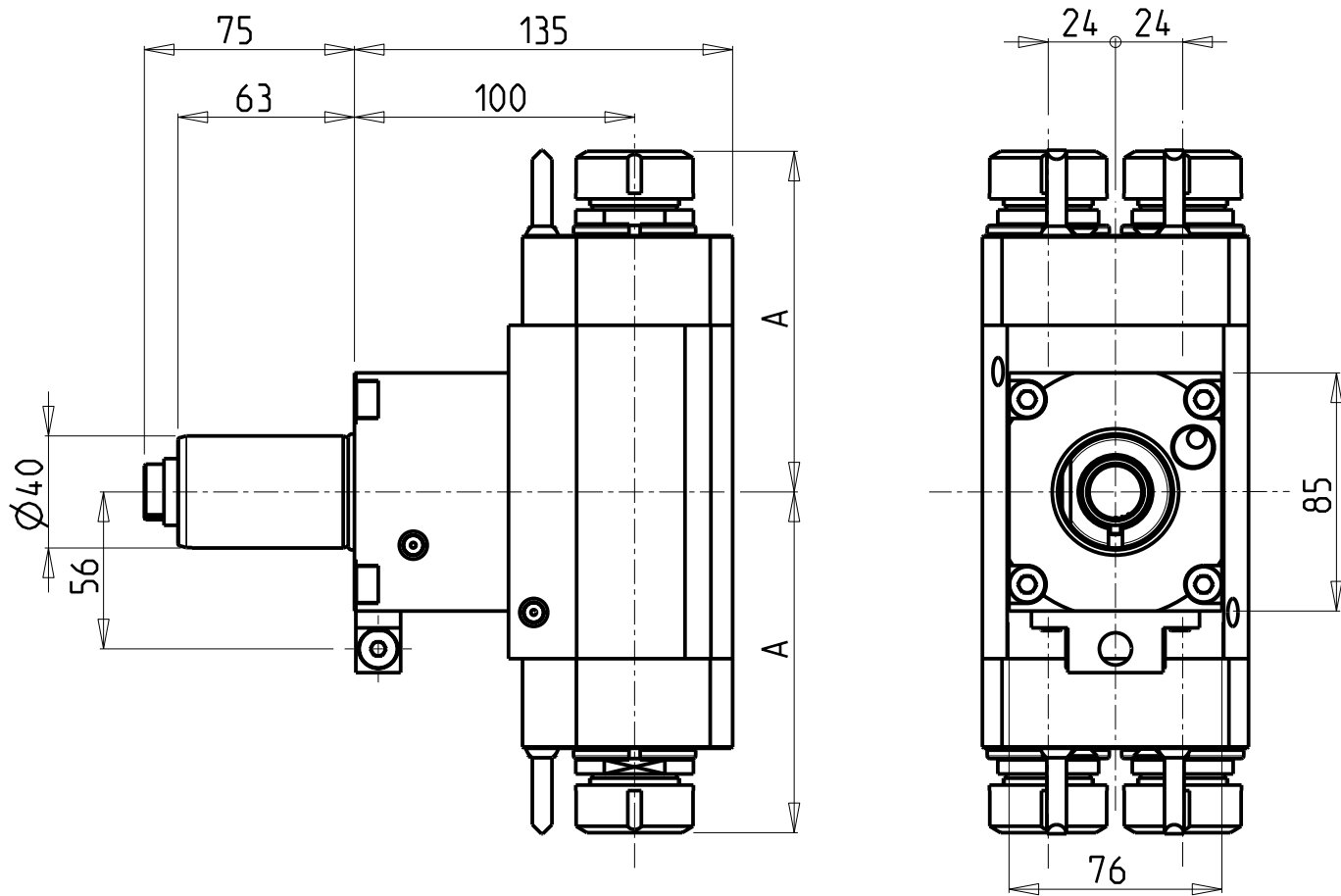

ATTENZIONE - ATTENTION - ACHTUNG

- Per lo smontaggio degli utensili utilizzare sempre la chiave di contrasto come indicato nel manuale d'uso.
- For disassembly of the tools use always the contrast key as mentioned in the user instructions.
- Fuer das Abmontieren der Werkzeuge immer den Gegenschlüssel benutzen wie in der Bedienungsanleitung erwäehnt.

Cod. MT	Mandrino Spindle Spindel	I	RPM	Coppia Max Max Torque Max Drehmoment	N°Utensili N°Tools N°Werkzeuge	Lubrificazione est. Ext. coolant Ausseukuehlung	A	CHIAVI NON INCLUSE Keys not included Schluessel nicht einbegriffen	
SAU0510216	ER16+ER16	1:1	6000	50Nm	2+2	X	120.7	CHUB17	CHMNER16
SAU0510225	ER25+ER25	1:1	6000	50Nm	2+2	X	121.6	CHUB36	CHSTER25

SAUTER
VDI 40
MODULO MOTORIZZATO RADIALE 2+2 USCITE IN Y VDI40 DIN 5480
Radial multiple 2+2 outlet driven tool in Y VDI40 DIN 5480
Radial angetriebenes Mehrspindel-Werkzeug 2+2 Ausgaenge in Y VDI40 DIN 5480

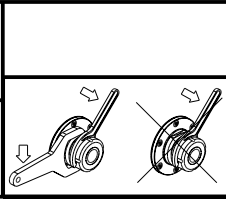

M.T. srl
Via Casino Albini 480
Tel. 0541/956034-957884
Fax 0541/956341
47842 S. GIOVANNI IN M. (RN)
e-mail: mtma@mtmarchetti.com
http://www.mtmarchetti.com

PRODUZIONE MODULI ROTANTI

PAGINA SAU020-3-00

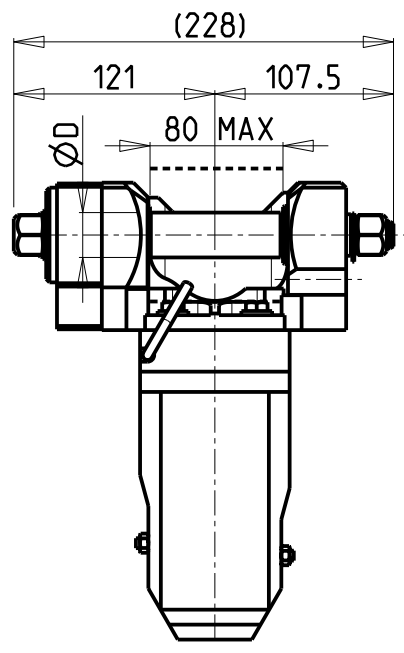
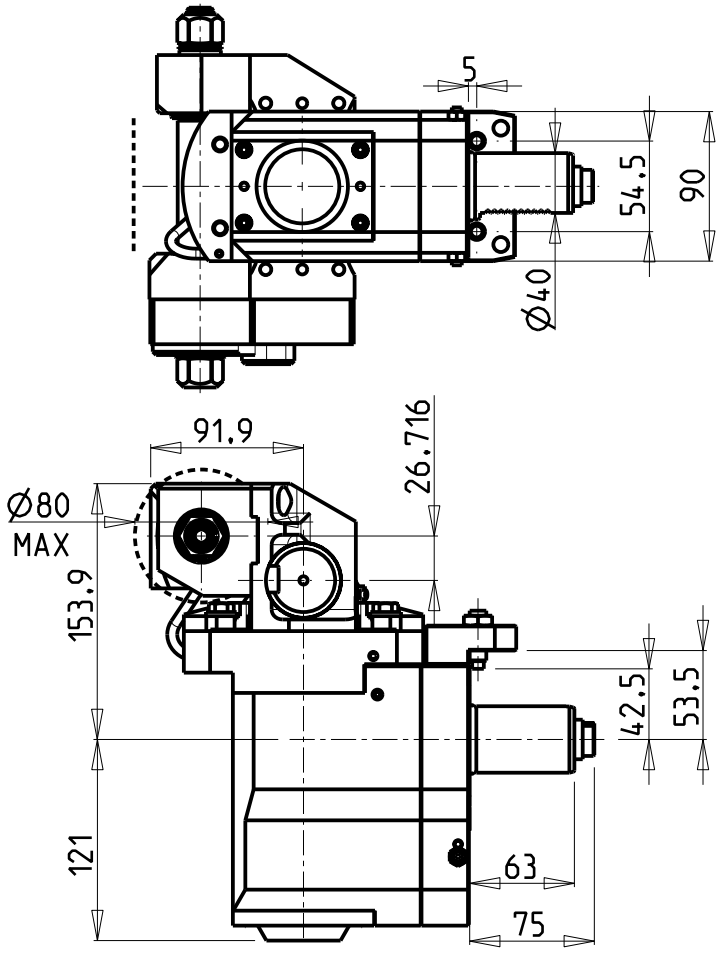

versione dx
right version
version rechts

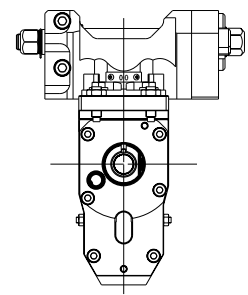

versione universale
universal version
universal version

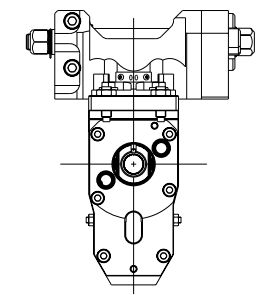

**TORRETTE ASSIALI
AXIAL TURRETS
AXIAL REVOLVER**

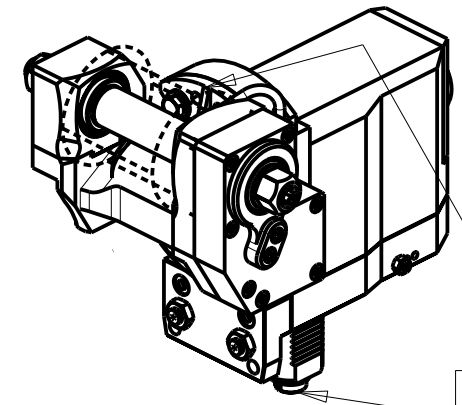
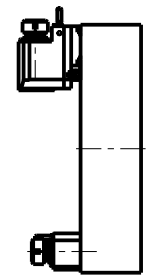

INCLINAZIONE
REGOLABILE ±20°

DIN 5480

PER ALBERI E DISTANZIALI VEDI PAG. TBL250-1-00
FOR SHAFT END SPACER SEE PAGE TBL250-1-00
FUER DORN UND ABSTANDSSTUECK SEITE TBL250-1-00

Cod. MT		I	RPM	Coppia Max Max Torque Max Drehmoment	Lubrificazione est. Ext. coolant Aussenkuehlung	D (mm)	D (Inch)	CHIAVI INCLUSE Keys included Schluessel einbegriffen			DOTAZIONI - SUPPLIED WITH - AUSSTATTUNG	
versione dx right version version rechts	versione universale universal version universal version							mm / inch	- N°1 ALBERO + DISTANZIALI - N°1 SHAFT + SPACER - N°1 DORN + ABSTANDSSTUECK			
SAU0011140	SAU0015140	1:1	6000	60Nm	X	16-22-27-32	3/4"-1"-1 1/4"	CHUB24	CHUB13	CHESL08		
SAU0012140	SAU0016140	2:1	3000	80Nm	X	16-22-27-32	3/4"-1"-1 1/4"	CHUB24	CHUB13	CHESL08		

SAUTER
VDI 40
MODULO MOTORIZZATO PORTACREATORE VDI40 DIN 5480
Driven gear hobber VDI40 DIN 5480
Angetriebenes Zahnradwaelzfraes-Werkzeug VDI40 DIN 5480

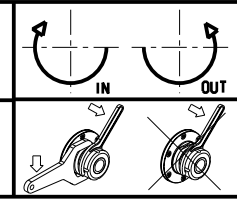

M.T. srl
Via Casino Albini 480
Tel. 0541/956034-957884
Fax 0541/956341
47842 S. GIOVANNI IN M. (RN)
e-mail: mtma@mtmarchetti.com
http://www.mtmarchetti.com

PRODUZIONE MODULI ROTANTI

PAGINA SAU340-3-00

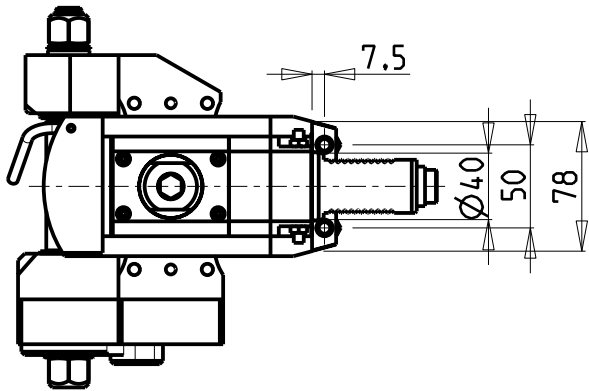

versione universale
universal version
universal version

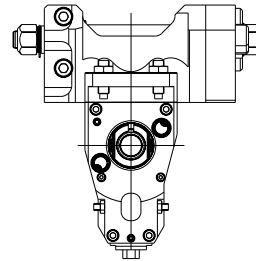

TORRETTE ASSIALI
AXIAL TURRETS
AXIAL REVOLVER

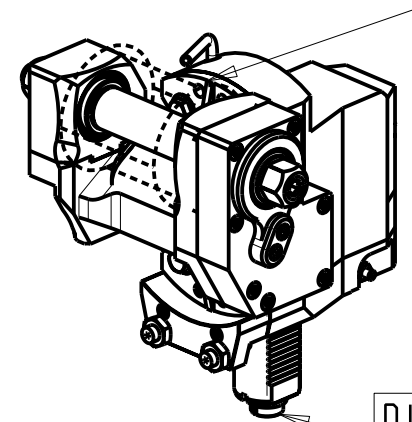
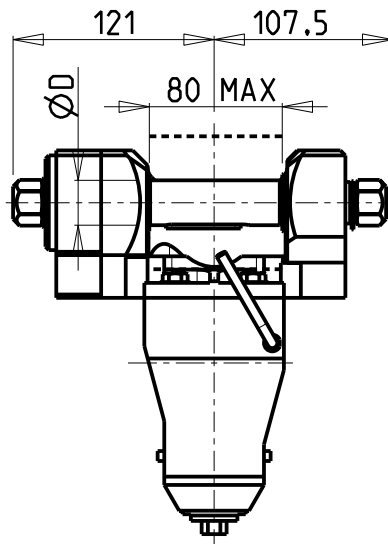
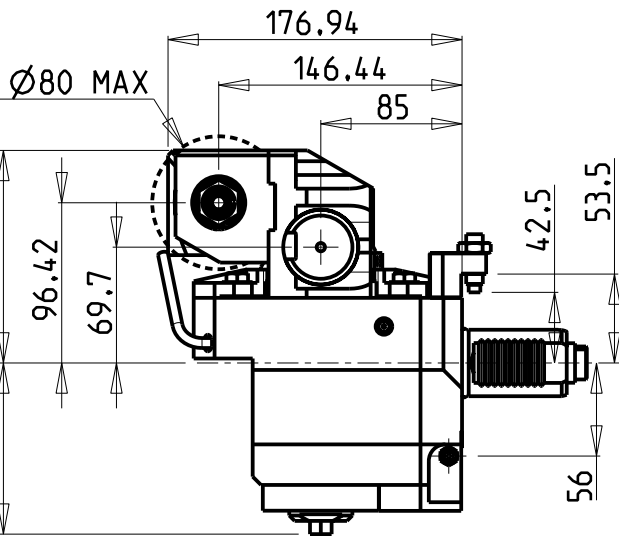
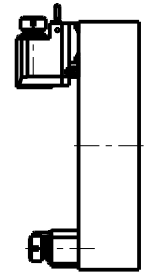

INCLINAZIONE
REGOLABILE $\pm 20^\circ$

DIN 5480

PER ALBERI E DISTANZIALI VEDI PAG. TBL250-1-00
FOR SHAFT END SPACER SEE PAGE TBL250-1-00
FUER DORN UND ABSTANDSSTUECK SEITE TBL250-1-00

DOTAZIONI - SUPPLIED WITH - AUSSTATTUNG

mm / inch	
	- N°1 ALBERO + DISTANZIALI
	- N°1 SHAFT + SPACER
	- N°1 DORN + ABSTANDSSTUECK

Cod. MT	I	RPM	Coppia Max Max Torque Max Drehmoment	Lubrificazione est. Ext. coolant Aussenkuehlung	D (mm)	D (Inch)	CHIAVI INCLUSE Keys included Schlüssel einbegriffen		
SAU0871120	1:1	6000	60Nm	X	16-22-27-32	3/4"-1"-1 1/4"	CHUB24	CHUB13	CHESL08
SAU0872120	2:1	3000	80Nm	X	16-22-27-32	3/4"-1"-1 1/4"	CHUB24	CHUB13	CHESL08

SAUTER
VDI 40

MODULO MOTORIZZATO PORTACREATORE VDI40 DIN 5480

Driven gear hobber VDI40 DIN 5480

Angetriebenes Zahnradwaelzfraes-Werkzeug VDI40 DIN 5480

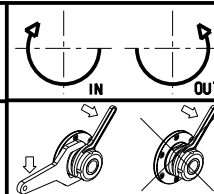

M.T. srl

Via Casino Albini 480
Tel. 0541/956034-957884
Fax 0541/956341

47842 S. GIOVANNI IN M. (RN)
e-mail: mtma@mtmarchetti.com
http://www.mtmarchetti.com

PRODUZIONE MODULI ROTANTI



PAGINA SAU340-3-01

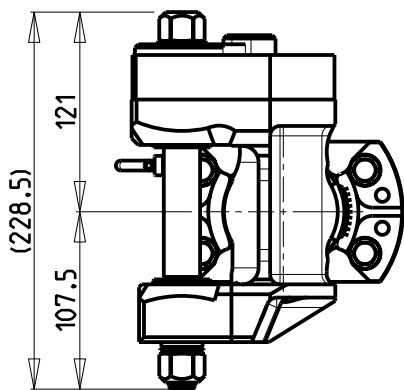
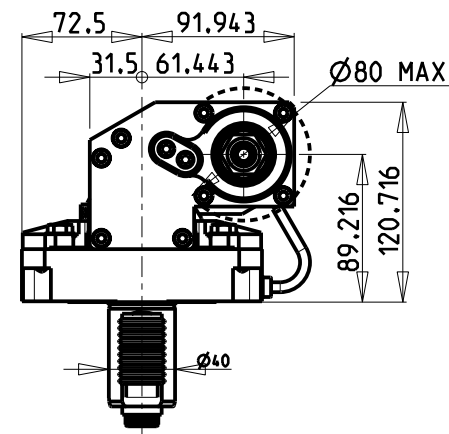
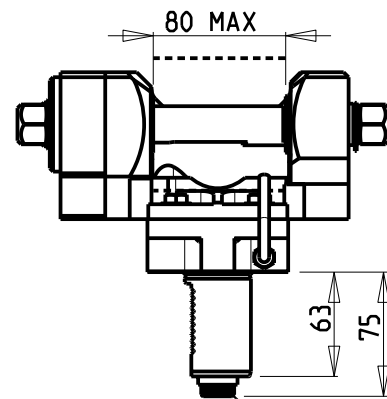
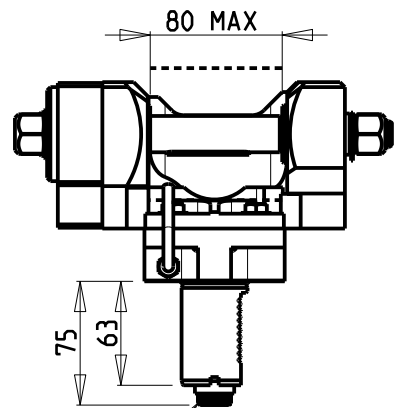
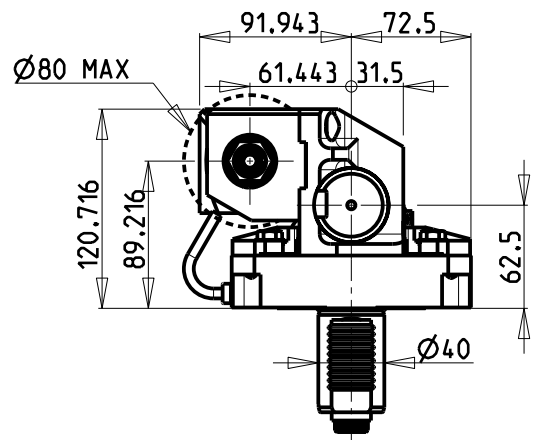

INCLINAZIONE
REGOLABILE ±20°

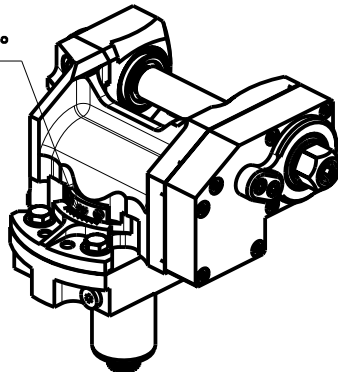

DIN 5480

DIN 5480

PER ALBERI E DISTANZIALI VEDI PAG. TBL250-1-00
FOR SHAFT END SPACER SEE PAGE TBL250-1-00
FUER DORN UND ABSTANDSSTUECK SEITE TBL250-1-00

DOTAZIONI - SUPPLIED WITH - AUSSTATTUNG

mm / inch	- N°1 ALBERO + DISTANZIALI
	- N°1 SHAFT + SPACER
	- N°1 DORN + ABSTANDSSTUECK

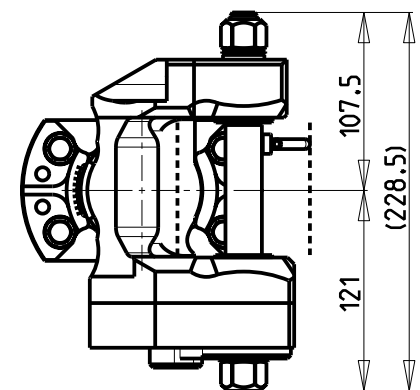

TORRETTE RADIALI
RADIAL TURRETS
RADIAL REVOLVER

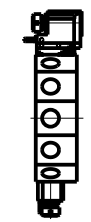

Cod. MT		I	RPM	Coppia Max Max Torque Max Drehmoment	Lubrificazione est. Ext. coolant Auslenkuehlung	D (mm)	D (Inch)	CHIAVI INCLUSE Keys included Schlüssel einbegriffen		
versione dx right version version rechts	versione sx left version version links							C HUB24	C HUB13	C HESL08
SAU0051100	SAU0051110	1:1	6000	60Nm	X	16-22-27-32	3/4"-1"-1 1/4"	C HUB24	C HUB13	C HESL08
SAU0052100	SAU0052110	2:1	3000	80Nm	X	16-22-27-32	3/4"-1"-1 1/4"	C HUB24	C HUB13	C HESL08

SAUTER
VDI 40

MODULO MOTORIZZATO PORTACREATORE VDI40 DIN 5480
Driven gear hobber VDI40 DIN 5480
Angetriebenes Zahnradwaelzfraes-Werkzeug VDI40 DIN 5480

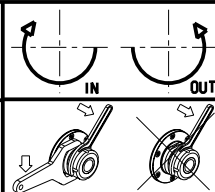

M.T. srl
Via Casino Albini 480
Tel. 0541/956034-957884
Fax 0541/956341
47842 S. GIOVANNI IN M. (RN)
e-mail: mtma@mtmarchetti.com
http://www.mtmarchetti.com

PRODUZIONE MODULI ROTANTI



PAGINA SAU340-3-05

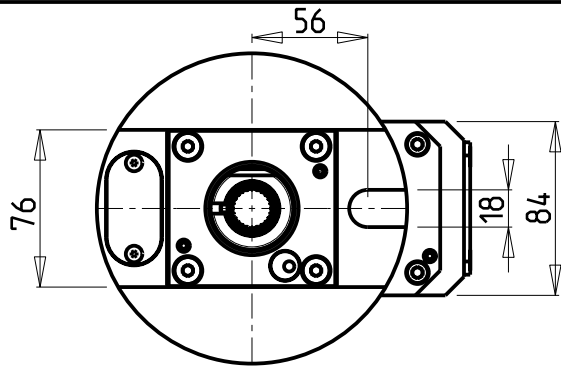

versione dx
right version
version rechts

versione sx
left version
version links

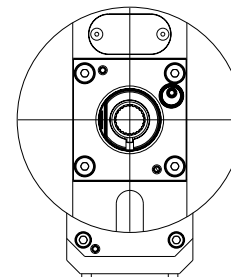
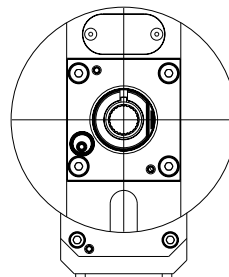

ATTENZIONE - ATTENTION - ACHTUNG

- VERIFICARE LE MISURE DI INGOMBRO PER POSSIBILE INTERFERENZA SU ALCUNI MODELLI DI MACCHINE
- Please check the overall sizes for possible interferences on some machine models
- Bitte überprüfen sie das ausmass um mögliche interferenzen auf einigen maschinen modellen zu vermeiden

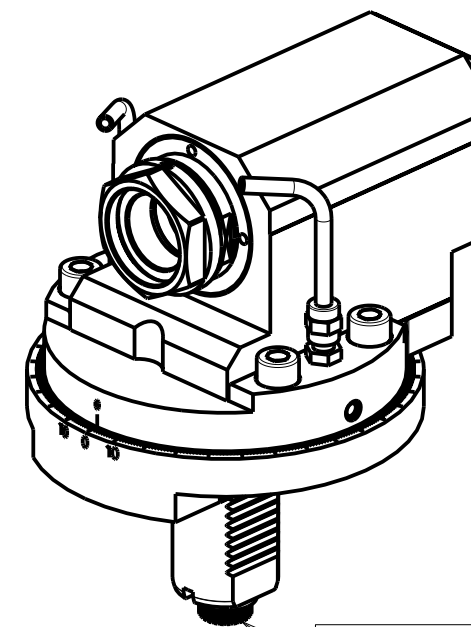
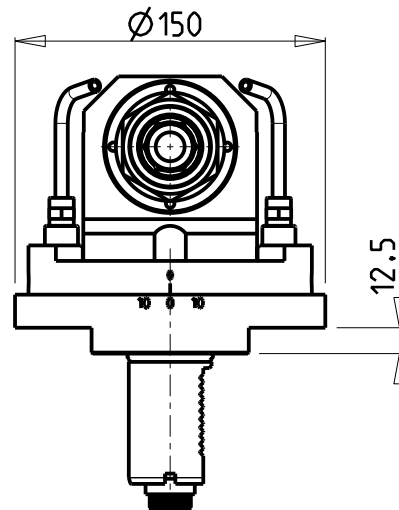
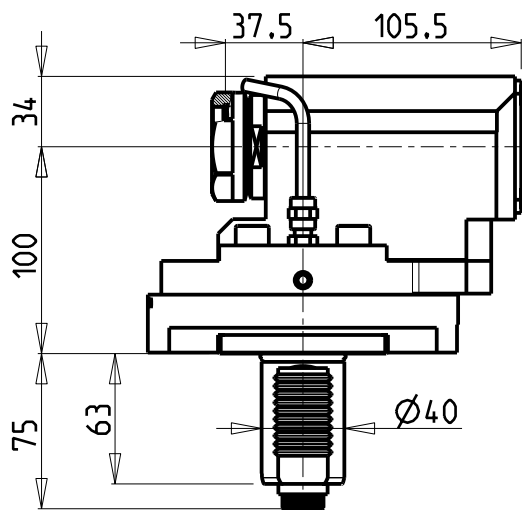

DIN 5480

PER PORTAUTENSILI MODULARI MTSK-40 VEDI PAG. TBL300-1-40
FOR MTSK-40 QUIK CHANGE TOOLHOLDERS CLAMPINGS SEE PAGE TBL300-1-40
FUER MTSK-40 MODULARE WERKZEUGAUFNAHMEN SIEHE SEITE TBL300-1-40

Cod. MT		Mandrino Spindle Spindel	I	RPM	Coppia Max Max Torque Max Drehmoment	Lubrificazione est. Ext. coolant Aussehenkuehlung	CHIAVI INCLUSE Keys included Schluessel einbegriffen
versione dx right version version rechts	versione sx left version version links						
SAU0760100	SAU0761100	MTSK-40	1:1	6000	50Nm	X	n°2 CHUB46

SAUTER
VDI 40

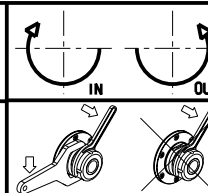

M.T. srl
Via Casino Albini 480
Tel. 0541/956034-957884
Fax 0541/956341
47842 S. GIOVANNI IN M. (RN)
e-mail: mtma@mtmarchetti.com
http://www.mtmarchetti.com

PRODUZIONE MODULI ROTANTI



MODULO MOTORIZZATO ASSIALE MTSK PER POWER SKIVING H=100mm VDI40 DIN 5480
Axial MTSK driven tool for Power Skiving H=100mm VDI40 DIN 5480
Axial MTSK angetriebenes Werkzeug fuer Power Skiving H=100mm VDI40 DIN 5480

PAGINA SAU350-3-00-K

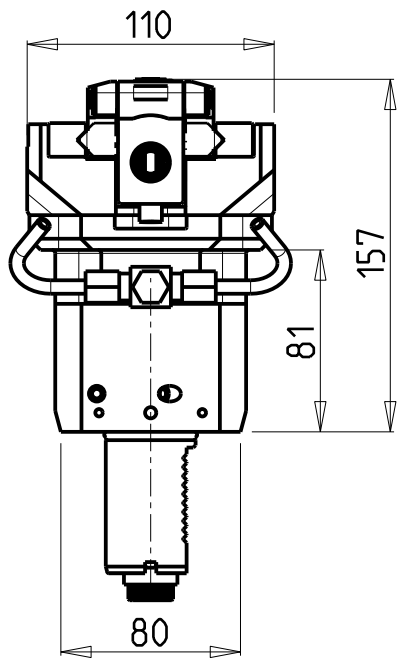
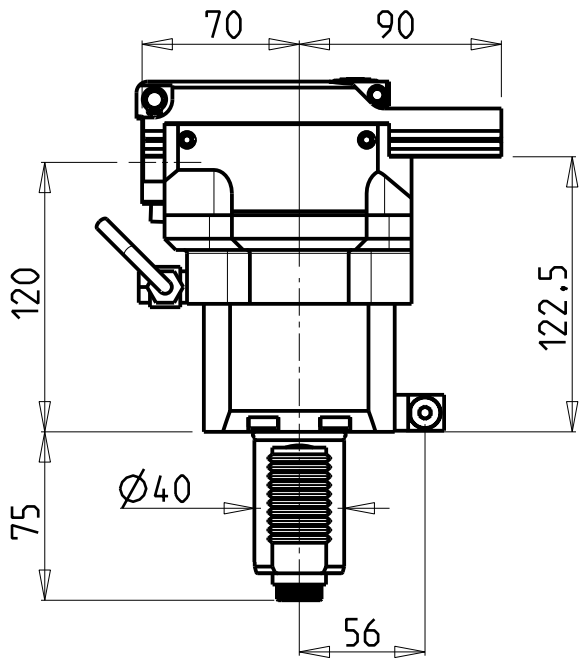

versione dx
right version
version rechts

versione sx
left version
version links

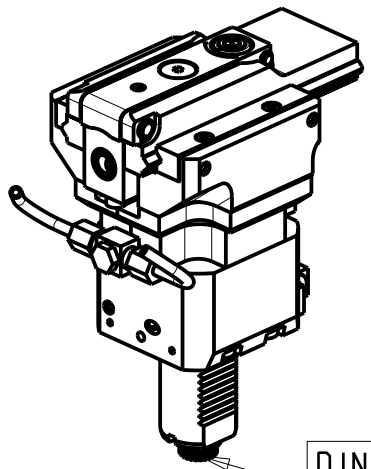
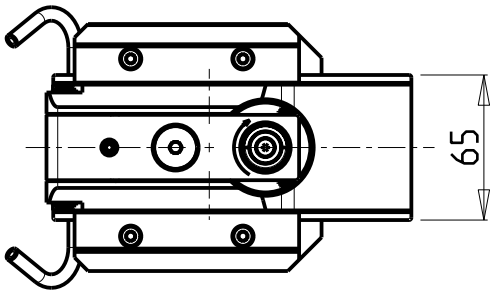
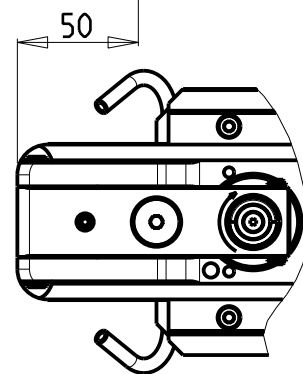
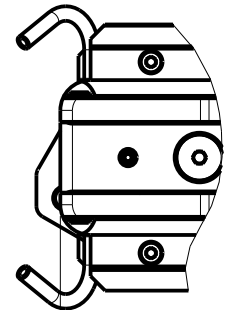
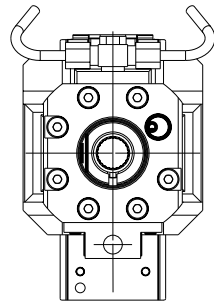
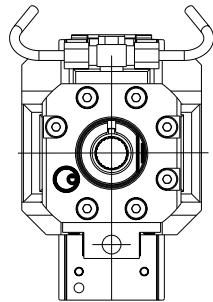

DIN 5480

PER UTENSILI STOZZATORI VEDI PAG. TBL400-1-00
FOR DRIVEN SLOTTING TOOL CUTTING-TOOLS SEE PAGE TBL400-1-00
FÜR NUTENSTOSS-WERKZEUG SCHNEIDWERKZEUGE SIEHE SEITE TBL400-1-00

Cod. MT		i	RPM MAX	Lubr. esterna Ext. coolant Aussenkuehlung
versione dx right version version rechts	versione sx left version version links			
SAU0720100	SAU0721100	4:1	2000	X

SAUTER
VDI 40
MODULO MOTORIZZATO STOZZATORE CORSA 50mm H=120mm VDI40 DIN 5480
Slotting driven tool 50mm stroke H=120mm VDI40 DIN 5480
Keilnutenstossmaschine 50mm Hub H=120mm VDI40 DIN 5480

M.T. srl
Via Casino Albini 480
Tel. 0541/956034-957884
Fax 0541/956341
47842 S. GIOVANNI IN M. (RN)
e-mail: mtma@mtmarchetti.com
http://www.mtmarchetti.com

PRODUZIONE MODULI ROTANTI



PAGINA SAU360-3-00

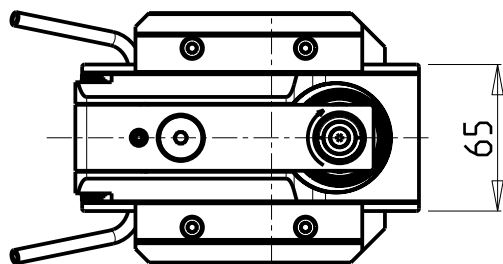
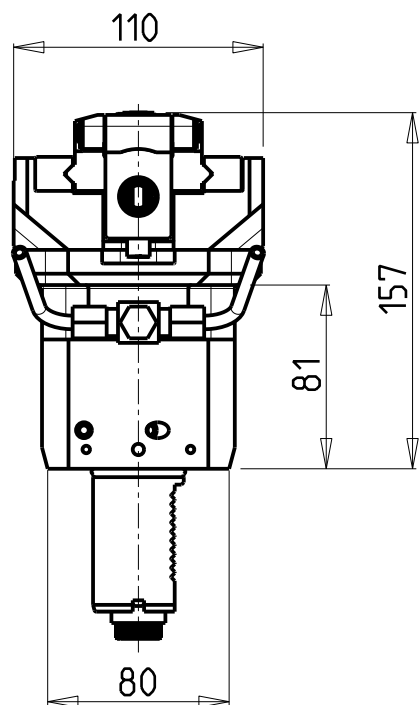
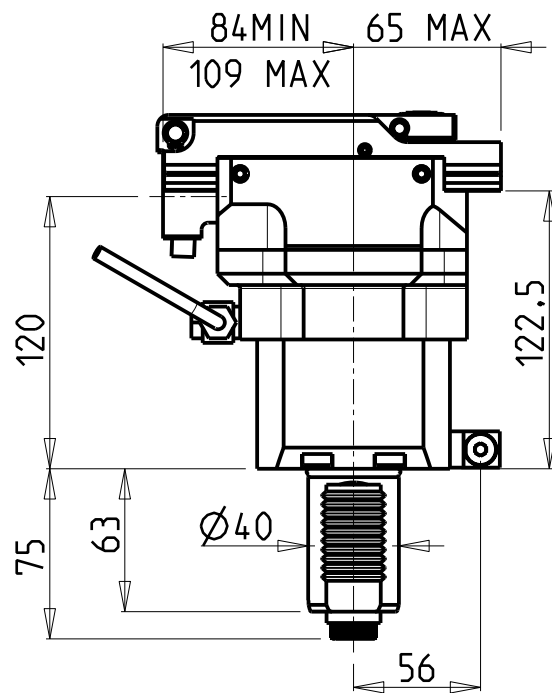

versione dx
right version
version rechts

versione sx
left version
version links

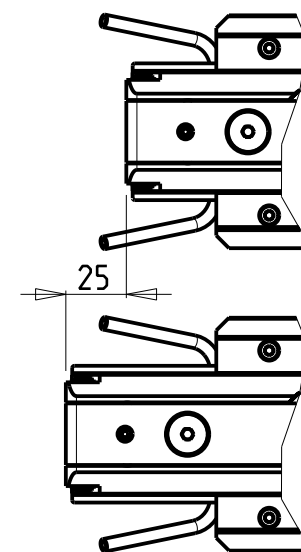
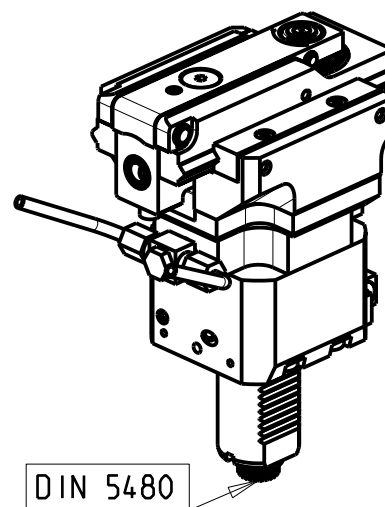
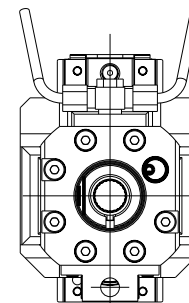
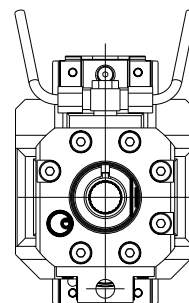

PER UTENSILI STOZZATORI VEDI PAG. TBL400-1-00
FOR DRIVEN SLOTTING TOOL CUTTING-TOOLS SEE PAGE TBL400-1-00
FÜR NUTENSTOSS-WERKZEUG SCHNEIDWERKZEUGE SIEHE SEITE TBL400-1-00

Cod. MT		I	RPM MAX	Lubr. esterna Ext. coolant Aussenkuehlung
versione dx right version version rechts	versione sx left version version links			
SAU0720200	SAU0721200	4:1	2400	X

SAUTER
VDI 40

MODULO MOTORIZZATO STOZZATORE CORSA 25mm H=120mm VDI40 DIN 5480
Slotting driven tool 25mm stroke H=120mm VDI40 DIN 5480
Keilnutenstossmaschine 25mm Hub H=120mm VDI40 DIN 5480

M.T. srl

Via Casino Albini 480
Tel. 0541/956034-957884
Fax 0541/956341
47842 S. GIOVANNI IN M. (RN)
e-mail: mtma@mtmarchetti.com
http://www.mtmarchetti.com

PRODUZIONE MODULI ROTANTI



PAGINA SAU360-3-01

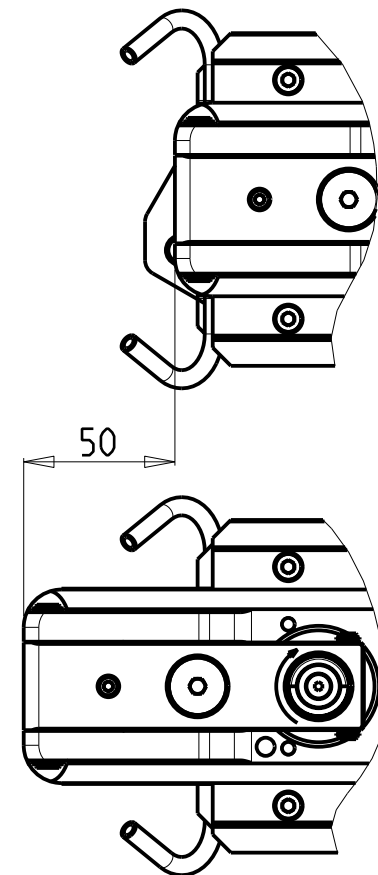
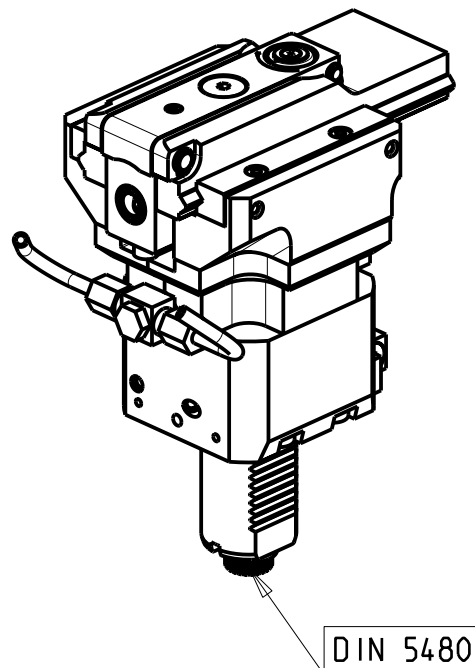
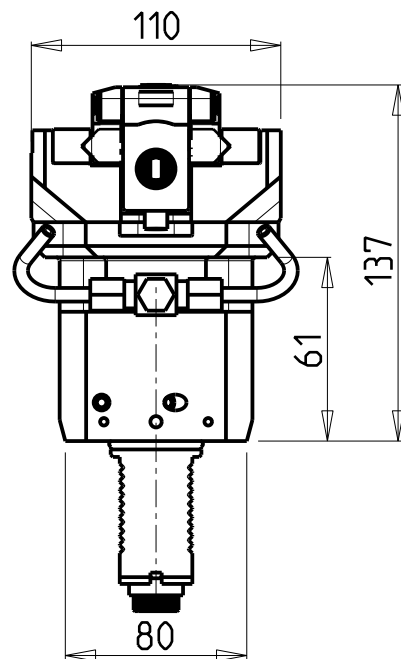
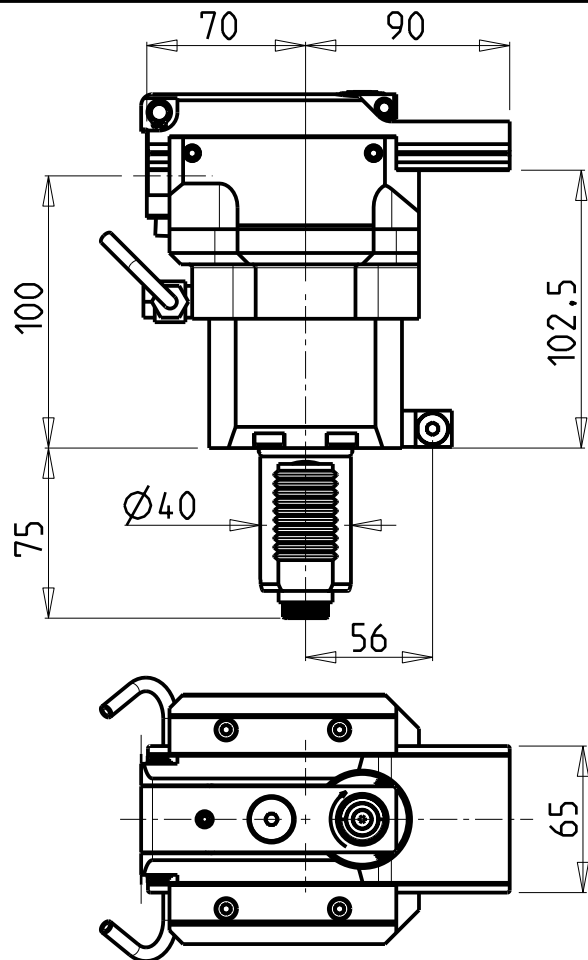

PER UTENSILI STOZZATORI VEDI PAG. TBL400-1-00
 FOR DRIVEN SLOTTING TOOL CUTTING-TOOLS SEE PAGE TBL400-1-00
 FÜR NUTENSTOSS-WERKZEUG SCHNEIDEWERKZEUGE SIEHE SEITE TBL400-1-00

Cod. MT		RPM MAX	Lubrificazione est. Ext. coolant Auslenkuehlung
versione universale universal version universal version	I		
SAU0782100	4:1	2000	X

SAUTER
VDI 40

MODULO MOTORIZZATO STOZZATORE CORSA 50mm H=100mm VDI40 DIN 5480
 Slotting driven tool 50mm stroke H=100mm VDI40 DIN 5480
 Keilnutenstossmaschine 50mm Hub H=100mm VDI40 DIN 5480

M.T. srl

Via Casino Albini 480
 Tel. 0541/956034-957884
 Fax 0541/956341
 47842 S. GIOVANNI IN M. (RN)
 e-mail: mtma@mtmarchetti.com
 http://www.mtmarchetti.com

PRODUZIONE MODULI ROTANTI



PAGINA SAU360-3-10

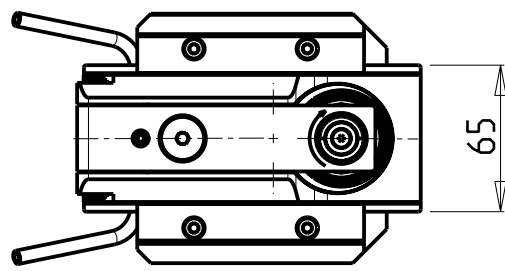
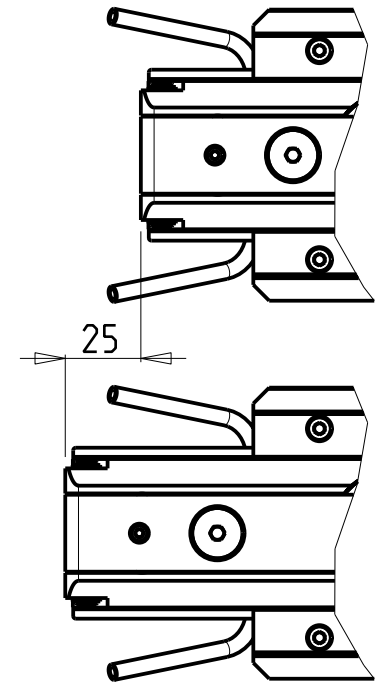
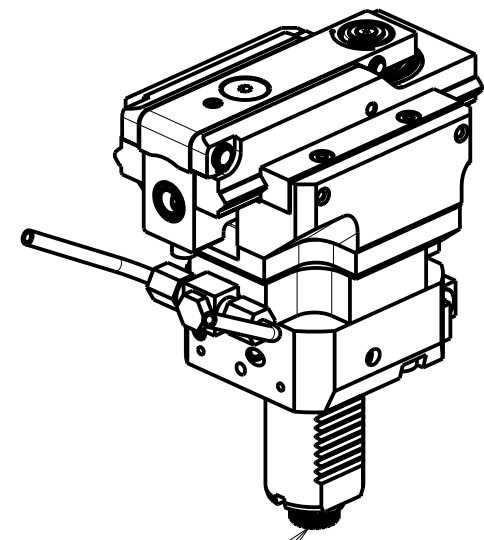
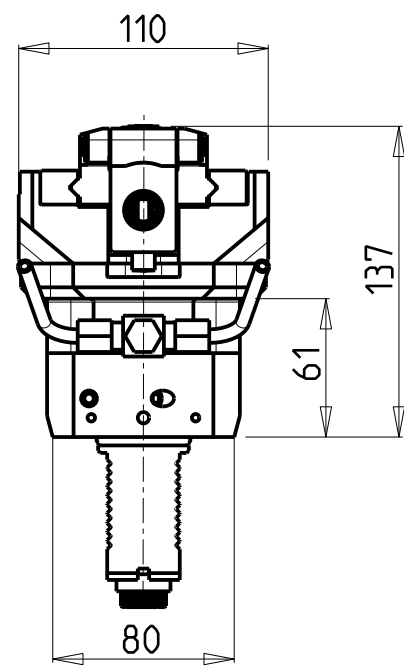
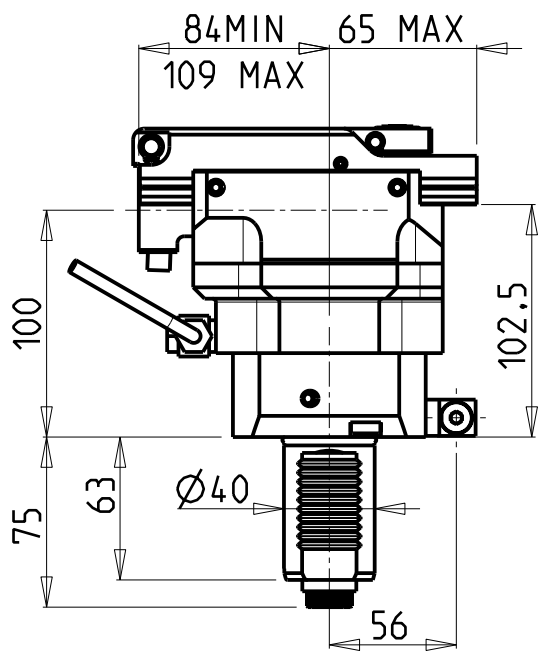

PER UTENSILI STOZZATORI VEDI PAG. TBL400-1-00
 FOR DRIVEN SLOTTING TOOL CUTTING-TOOLS SEE PAGE TBL400-1-00
 FÜR NUTENSTOSS-WERKZEUG SCHNEIDWERKZEUGE SIEHE SEITE TBL400-1-00

Cod. MT	I	RPM MAX	Lubrificazione est. Ext. coolant Aussenkuehlung
SAU0782200	4:1	2400	X

SAUTER
 VDI 40

MODULO MOTORIZZATO STOZZATORE CORSA 25mm H=100mm VDI40 DIN 5480
 Slotting driven tool 25mm stroke H=100mm VDI40 DIN 5480
 Keilnutenstossmaschine 25mm Hub H=100mm VDI40 DIN 5480



M.T. srl
 Via Casino Albini 480
 Tel. 0541/956034-957884
 Fax 0541/956341
 47842 S. GIOVANNI IN M. (RN)
 e-mail: mtma@mtmarchetti.com
 http://www.mtmarchetti.com

PRODUZIONE MODULI ROTANTI



PAGINA SAU360-3-11

