

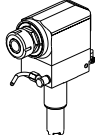

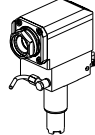

		PAGINA Page Seite
<p>MODULO MOTORIZZATO RADIALE VDI40 Radial driven tool VDI40 Radial angetriebenes Werkzeug VDI40</p>		HAS013.1.20
<p>MODULO MOTORIZZATO RADIALE MTSK VDI40 Radial MTSK driven tool VDI40 Radial MTSK angetriebenes Werkzeug VDI40</p>		HAS013.1.20.K
<p>MODULO MOTORIZZATO RADIALE ARRETRATO VDI40 Radial rear-set driven tool VDI40 Radial angetriebenes Werkzeug zurueckversetzt VDI40</p>		HAS015.1.00
<p>MODULO MOTORIZZATO ASSIALE VDI40 Axial driven tool VDI40 Axial angetriebenes Werkzeug VDI40</p>		HAS150.1.10
<p>MODULO MOTORIZZATO ASSIALE DISASSATO 42mm VDI40 Axial driven tool re-directed by 42mm VDI40 Axial angetriebenes Werkzeug achsversetzt um 42mm VDI40</p>		HAS160.1.00
<p>MODULO MOTORIZZ. ASSIALE MOLTIPLICATO I=1:2 DISASSATO 42mm VDI40 Axial geared-up I=1:2 driven tool re-directed by 42mm VDI40 Axial angetriebenes Werkzeug uebersetzt I=1:2 achsversetzt um 42mm VDI40</p>		HAS160.1.20
<p>MODULO MOTORIZZ. ASSIALE MOLTIPLICATO I=1:3 DISASSATO 36mm VDI40 Axial geared-up I=1:3 driven tool re-directed by 36mm VDI40 Axial angetriebenes Werkzeug uebersetzt I=1:3 achsversetzt um 36mm VDI40</p>		HAS160.1.30
<p>MODULO MOTORIZZATO RADIALE MOLTIPLICATO I=1:2 VDI40 Radial geared-up I=1:2 driven tool VDI40 Radial angetriebenes Werkzeug uebersetzt I=1:2 VDI40</p>		HAS203.1.10
<p>MODULO MOTORIZZATO RADIALE MOLTIPLICATO I=1:3 VDI40 Radial geared-up I=1:3 driven tool VDI40 Radial angetriebenes Werkzeug uebersetzt I=1:3 VDI40</p>		HAS208.1.10
<p>MODULO MOTORIZZATO RADIALE ARRETRATO MOLTIPLICATO I=1:3 VDI40 Radial geared-up I=1:3 rear-set driven tool VDI40 Radial angetriebenes Werkzeug uebersetzt I=1:3 zurueckversetzt VDI40</p>		HAS226.1.10
<p>MODULO MOTORIZZATO ORIENTABILE 0-90° VDI40 0-90° adjustable angle driven tool VDI40 Angetriebenes Werkzeug schwenkbar 0-90° VDI40</p>		HAS330.1.00
<p>MODULO MOTORIZZATO ORIENTABILE ±90° VDI40 ±90° adjustable angle driven tool VDI40 Angetriebenes Werkzeug schwenkbar ±90° VDI40</p>		HAS333.1.00 

		PAGINA Page Seite
<p>MODULO MOTORIZZATO ORIENTABILE $\pm 90^\circ$ CON NONIO DIGITALE VDI40 $\pm 90^\circ$ adjustable angle driven tool with digital display VDI40 Angetriebenes Werkzeug schwenkbar $\pm 90^\circ$ mit digital display VDI40</p>		HAS333.1.01
<p>MODULO MOTORIZZATO STOZZATORE CORSA 50mm VDI40 Slotting driven tool 50mm stroke VDI40 Keilnutenstossmaschine 50mm Hub VDI40</p>		HAS360.1.30
<p>MODULO MOTORIZZATO STOZZATORE CORSA 25mm VDI40 Slotting driven tool 25mm stroke VDI40 Keilnutenstossmaschine 25mm Hub VDI40</p>		HAS360.1.31

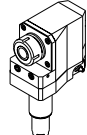
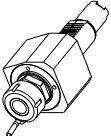
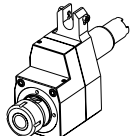
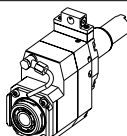
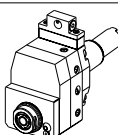

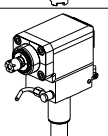
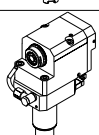
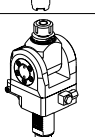
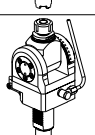
ATTENZIONE - ATTENTION - ACHTUNG

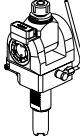
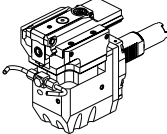
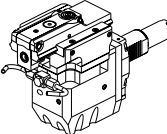
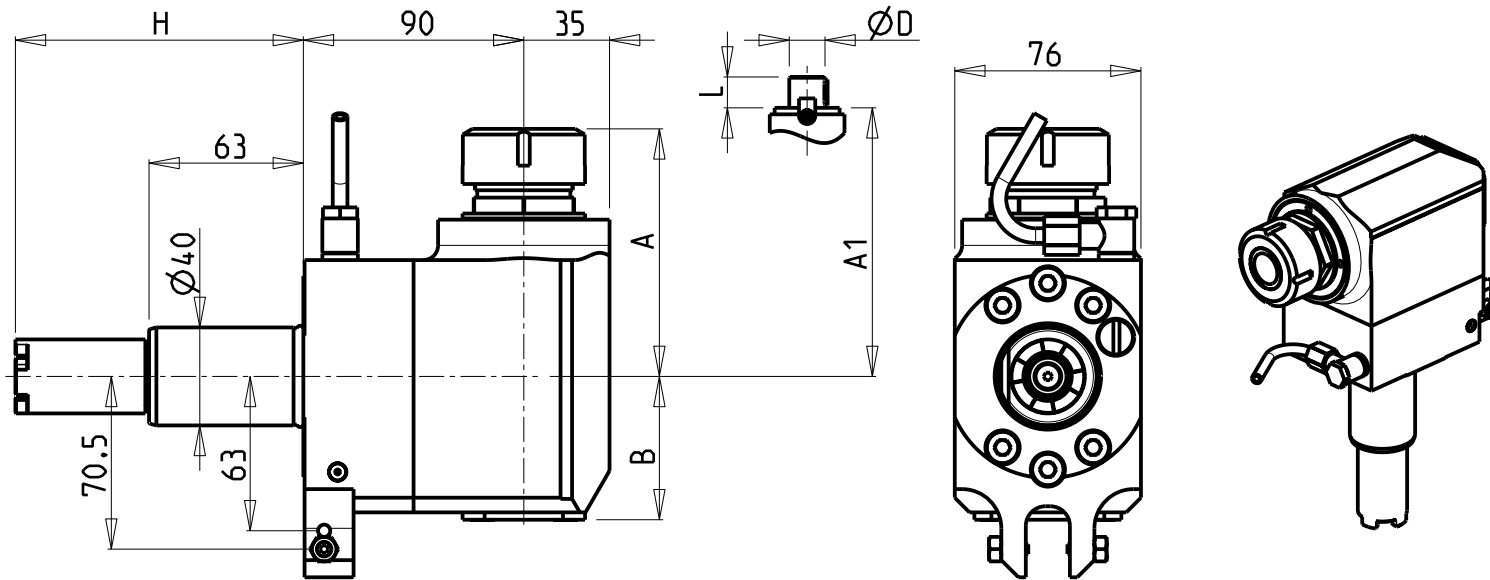
- Per lo smontaggio degli utensili utilizzare sempre la chiave di contrasto come indicato nel manuale d'uso.
- For disassembly of the tools use always the contrast key as mentioned in the user instructions.
- Fuer das Abmontieren der Werkzeuge immer den Gegenschlüssel benutzen wie in der Bedienungsanleitung erwäehnt.

- Chiave inclusa
- Key included
- Schlüssel inbegriffen

Cod. MT	Mandrino Spindle Spindel	I	RPM	Coppia Max Max Torque Max Drehmoment	Lubrificazione int. Coolant through Innenkühlung	Lubrificazione est. Ext. coolant Aussenkühlung	A	A1	B	H	Tipo Torretta Turret type Revolver typ	CHIAVI NON INCLUSE Keys not included Schlüssel nicht einbegriffen	
HAS0130132	ER32	1:1	6000	70Nm	-	X	101.1	-	58.5	104.85	VDI STANDARD	CHUB41	CHSTER32
HAS0130232	ER32	1:1	6000	70Nm	P=70bar	X	101.1	-	82	104.85	VDI STANDARD	CHUB41	CHSTER32
HAS0130140	ER40	1:1	6000	70Nm	-	X	103.7	-	58.5	104.85	VDI STANDARD	CHUB46	CHSTER40
HAS0130240	ER40	1:1	6000	70Nm	P=70bar	X	103.7	-	69.5	104.85	VDI STANDARD	CHUB46	CHSTER40
HAS0132219	Ø22x19	1:1	6000	70Nm	-	X	-	78.5	58.5	104.85	VDI STANDARD	CHUB41	CH_VTCROCE_M10 ■
HAS0132721	Ø27x21	1:1	6000	70Nm	-	X	-	78.5	58.5	104.85	VDI STANDARD	CHUB41	CH_VTCROCE_M12 ■
HAS0140132	ER32	1:1	6000	70Nm	-	X	101.1	-	58.5	117.55	HYBRID 12 TURRET	CHUB41	CHSTER32
HAS0140232	ER32	1:1	6000	70Nm	P=70bar	X	101.1	-	82	117.55	HYBRID 12 TURRET	CHUB41	CHSTER32
HAS0140140	ER40	1:1	6000	70Nm	-	X	103.7	-	58.5	117.55	HYBRID 12 TURRET	CHUB46	CHSTER40
HAS0140240	ER40	1:1	6000	70Nm	P=70bar	X	103.7	-	69.5	117.55	HYBRID 12 TURRET	CHUB46	CHSTER40
HAS0142219	Ø22x19	1:1	6000	70Nm	-	X	-	78.5	58.5	117.55	HYBRID 12 TURRET	CHUB41	CH_VTCROCE_M10 ■
HAS0142721	Ø27x21	1:1	6000	70Nm	-	X	-	78.5	58.5	117.55	HYBRID 12 TURRET	CHUB41	CH_VTCROCE_M12 ■

NEW
NEW

NEW
NEW

HAAS

MOD: SL10/20/30

MODULO MOTORIZZATO RADIALE VD140

Radial driven tool VD140

Radial angetriebenes Werkzeug VD140

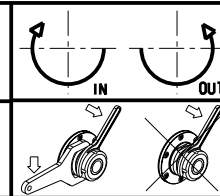

M.T. srl

Via Casino Albini 480
Tel. 0541/956034-957884

Fax 0541/956341

47842 S. GIOVANNI IN M. (RN)

e-mail: mtma@mtmarchetti.com

http://www.mtmarchetti.com

PRODUZIONE MODULI ROTANTI



PAGINA HAS013-1-20

ATTENZIONE - ATTENTION - ACHTUNG

- Per lo smontaggio degli utensili utilizzare sempre la chiave di contrasto come indicato nel manuale d'uso.
- For disassembly of the tools use always the contrast key as mentioned in the user instructions.
- Fuer das Abmontieren der Werkzeuge immer den Gegenschlüssel benutzen wie in der Bedienungsanleitung erwahnt.

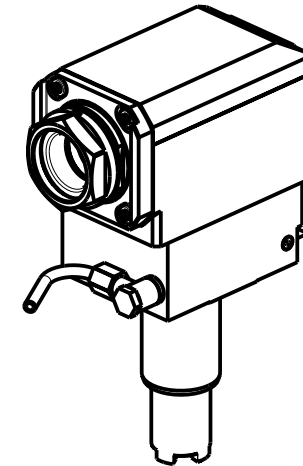
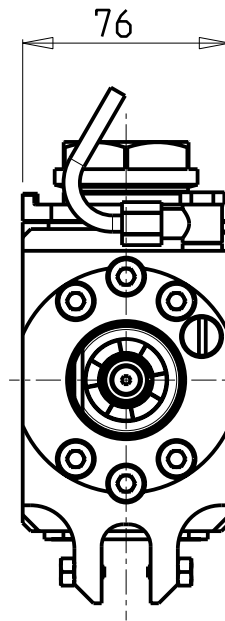
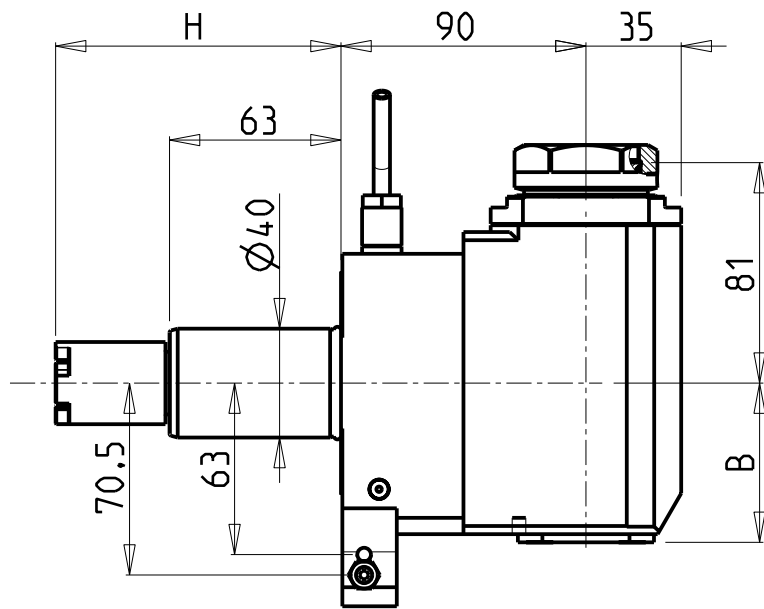

PER PORTAUTENSILI MODULARI MTSK-40 VEDI PAG. TBL300-1-40
 FOR MTSK-40 QUICK CHANGE TOOLHOLDERS CLAMPINGS SEE PAGE TBL300-1-40
 FUER MTSK-40 MODULARE WERKZEUGAUFNAHMEN SIEHE SEITE TBL300-1-40

- Chiave inclusa
- Key included
- Schlüssel inbegriffen

Cod. MT	Mandrino Spindle Spindel	I	RPM	Coppia Max Max Torque Max Drehmoment	Lubrificazione int. Coolant through Innenkuehlung	Lubrificazione est. Ext. coolant Aussenkuehlung	B	H	Tipo Torretta Turret type Revolver typ	CHIAVI NON INCLUSE Keys not included Schluessel nicht einbegriffen	
										C	K
HAS0270140	MTSK-40	1:1	6000	70Nm	-	X	58.5	104.85	VDI STANDARD	C HUB46	OKU0650004 •
HAS0270240	MTSK-40	1:1	6000	70Nm	P=70bar	X	69.5	104.85	VDI STANDARD	C HUB46	OKU0650004 •
HAS0280140	MTSK-40	1:1	6000	70Nm	-	X	58.5	117.55	HYBRID 12 TURRET	C HUB46	OKU0650004 •
HAS0280240	MTSK-40	1:1	6000	70Nm	P=70bar	X	69.5	117.55	HYBRID 12 TURRET	C HUB46	OKU0650004 •

HAAS

MOD: SL10/20/30

MODULO MOTORIZZATO RADIALE MTSK VDI40
 Radial MTSK driven tool VDI40
 Radial MTSK angetriebenes Werkzeug VDI40

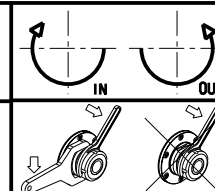

M.T. srl

Via Casino Albini 480
 Tel. 0541/956034-957884
 Fax 0541/956341
 47842 S. GIOVANNI IN M. (RN)
 e-mail: mtma@mtmarchetti.com
 http://www.mtmarchetti.com

PRODUZIONE MODULI ROTANTI



PAGINA HAS013-1-20-K

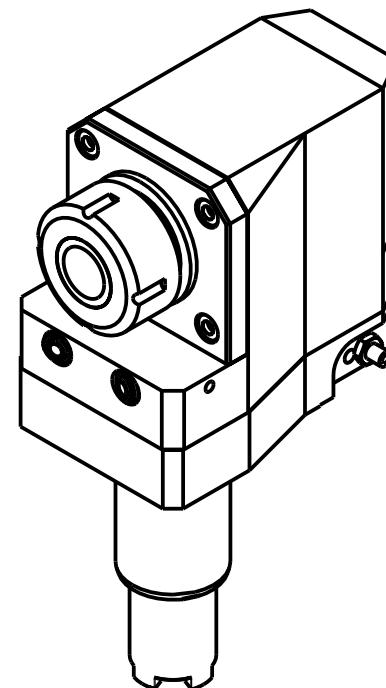
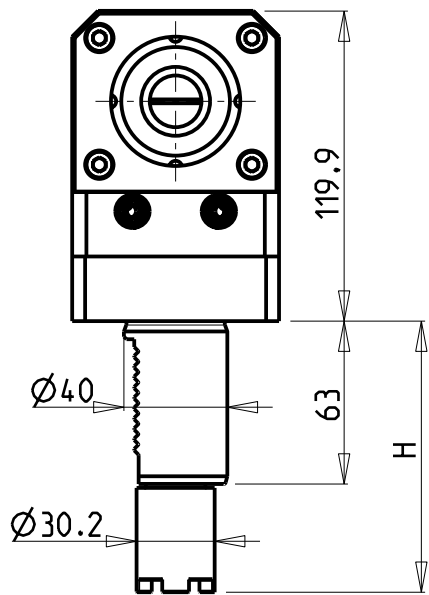
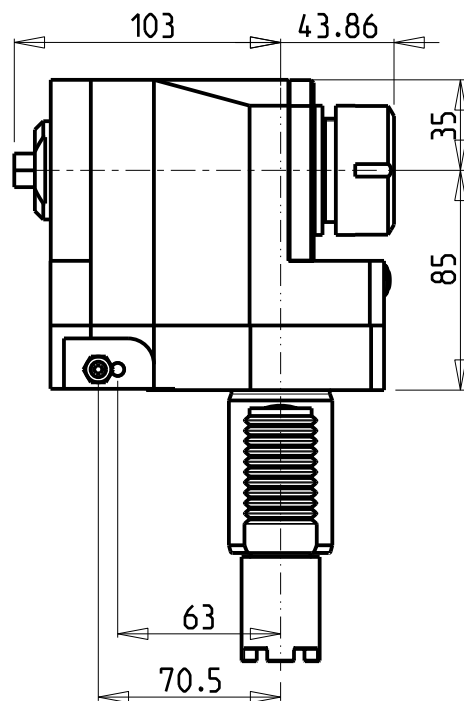
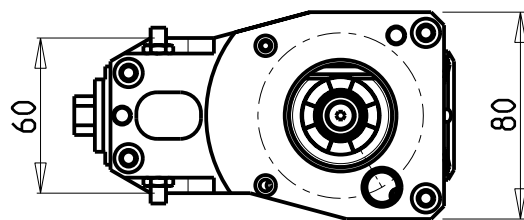

Cod. MT	Mandrino Spindle Spindel	I	RPM	Coppia Max Max Torque Max Drehmoment	Lubrificazione est. Ext. coolant Ausseukuehlung	H	Tipo Torretta Turret Type Revolver Typ	CHIAVI NON INCLUSE Keys not included Schluessel nicht einbegriffen	
HAS0030232	ER32	1:1	6000	70Nm	X	104.85	VDI STANDARD	CHUB13	CHSTER32
HAS0040232	ER32	1:1	6000	70Nm	X	117.55	HYBRID 12 TURRET	CHUB13	CHSTER32

HAAS
MOD: SL10/20/30

MODULO MOTORIZZATO RADIALE ARRETRATO VDI40
Radial rear-set driven tool VDI40
Radial angetriebenes Werkzeug zurueckversetzt VDI40

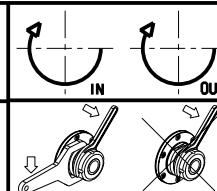

M.T. srl
Via Casino Albini 480
Tel. 0541/956034-957884
Fax 0541/956341
47842 S. GIOVANNI IN M. (RN)
e-mail: mtma@mtmarchetti.com
http://www.mtmarchetti.com

PRODUZIONE MODULI ROTANTI



PAGINA HAS015-1-00

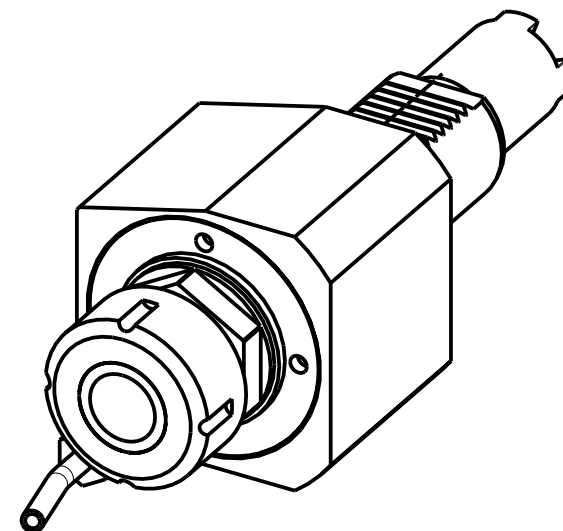
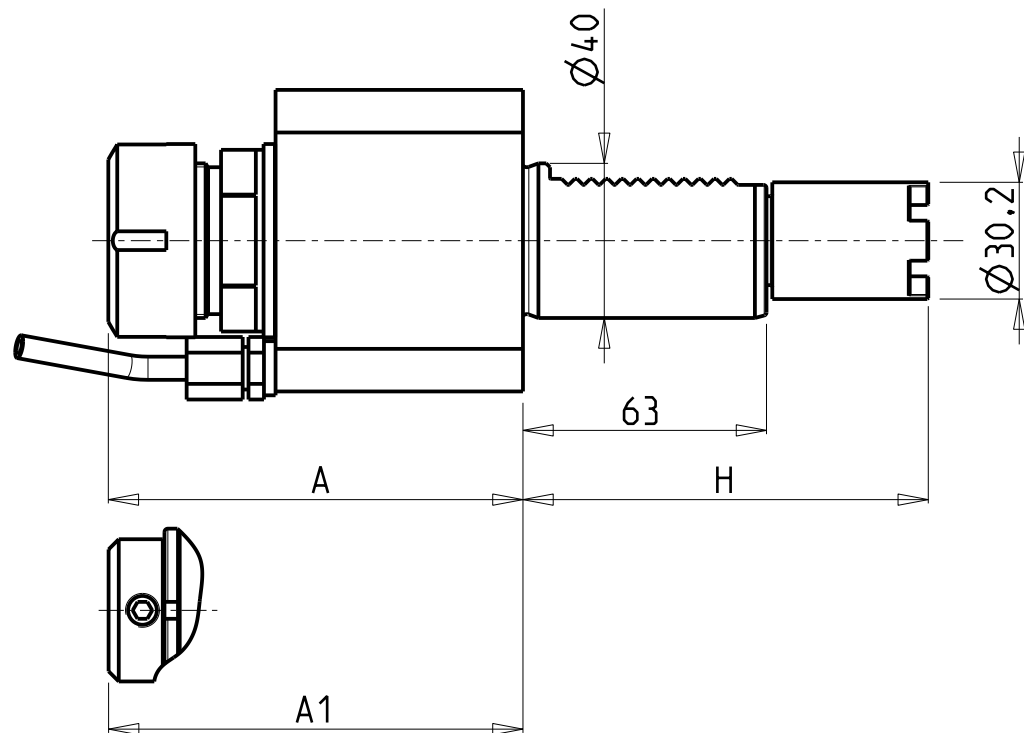
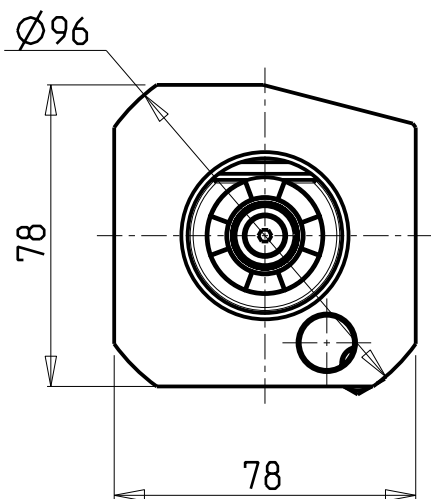

Cod. MT	Mandrino Spindle Spindel	I	RPM	Coppia Max Max Torque Max Drehmoment	Lubrificazione est. Ext. coolant Aussenkuehlung	Lubrificazione int. Coolant through Innenkuehlung	A	A1	H	Tipo Torretta Turret Type Revolver Typ	CHIAVI NON INCLUSE Keys not included Schluessel nicht einbegriffen	
											CHUB41	CHSTER32
HAS0010232	ER32	1:1	6000	70Nm	X	-	107.26	-	104.85	VDI STANDARD	CHUB41	CHSTER32
HAS0010132	ER32	1:1	6000	70Nm	X	P=30bar	110.46	-	104.85	VDI STANDARD	CHUB41	CHSTER32
HAS0010525	WELDON25	1:1	6000	70Nm	X	-	-	97.1	104.85	VDI STANDARD	-	-
HAS0020232	ER32	1:1	6000	70Nm	X	-	107.26	-	117.55	HYBRID 12 TURRET	CHUB41	CHSTER32
HAS0020132	ER32	1:1	6000	70Nm	X	P=30bar	110.46	-	117.55	HYBRID 12 TURRET	CHUB41	CHSTER32
HAS0020525	WELDON25	1:1	6000	70Nm	X	-	-	97.1	117.55	HYBRID 12 TURRET	-	-

HAAS

MOD: SL10/20/30

MODULO MOTORIZZATO ASSIALE VDI40

Axial driven tool VDI40

Axial angetriebenes Werkzeug VDI40

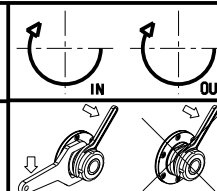

M.T. srl

Via Casino Albini 480
Tel. 0541/956034-957884

Fax 0541/956341

47842 S. GIOVANNI IN M. (RN)

e-mail: mtma@mtmarchetti.com

http://www.mtmarchetti.com

PRODUZIONE MODULI ROTANTI



PAGINA HAS150-1-10

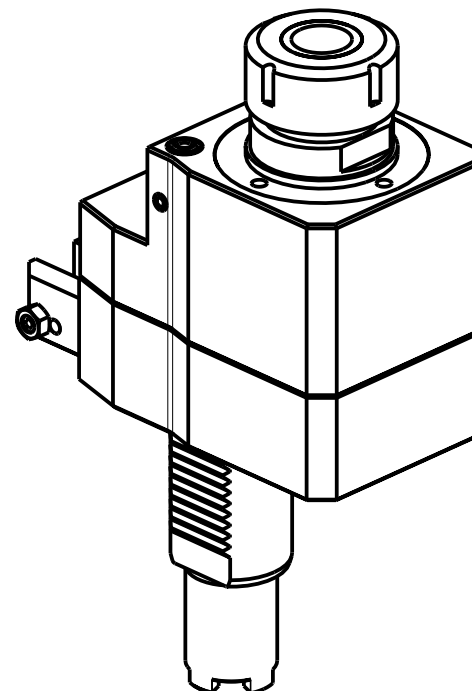
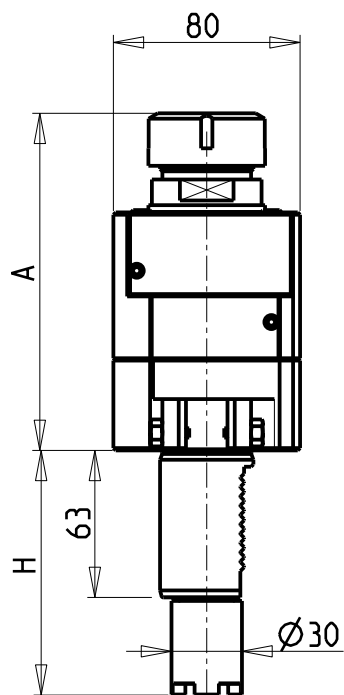
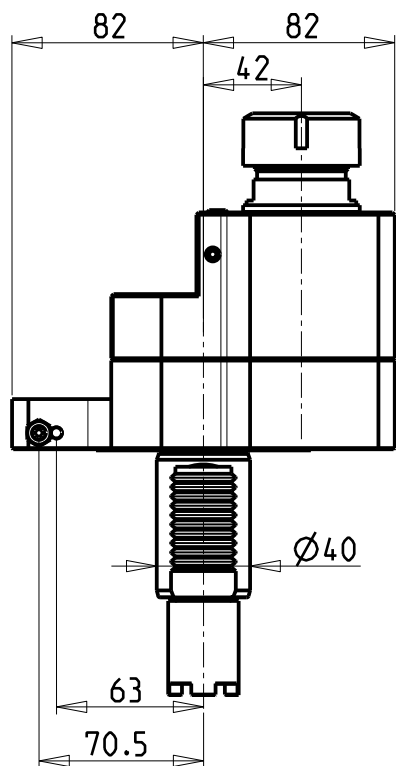

Cod. MT	Mandrino Spindle Spindel	I	RPM	Coppia Max Max Torque Max Drehmoment	Lubrificazione int. Coolant through Innenkühlung	Lubrificazione est. Ext. coolant Aussenkühlung	A	H	Tipo Torretta Turret Type Revolver Typ	CHIAVI NON INCLUSE Keys not included Schlüssel nicht einbegriffen	
HAS0070032	ER32	1:1	6000	70Nm		X	144.66	104.85	VDI STANDARD	CHUB41	CHSTER32
HAS0071132	ER32	1:1	6000	70Nm	P=30bar		164.96	104.85	VDI STANDARD	CHUB38	CHSTER32
HAS0072132	ER32	2:1	3000	100Nm		X	144.66	104.85	VDI STANDARD	CHUB41	CHSTER32
HAS0074232	ER32	2:1	3000	100Nm	P=30bar		164.96	104.85	VDI STANDARD	CHUB38	CHSTER32
HAS0080032	ER32	1:1	6000	70Nm		X	144.66	117.55	HYBRID 12 TURRET	CHUB41	CHSTER32
HAS0081132	ER32	1:1	6000	70Nm	P=30bar		164.96	117.55	HYBRID 12 TURRET	CHUB38	CHSTER32
HAS0082132	ER32	2:1	3000	100Nm		X	144.66	117.55	HYBRID 12 TURRET	CHUB41	CHSTER32
HAS0084232	ER32	2:1	3000	100Nm	P=30bar		164.96	117.55	HYBRID 12 TURRET	CHUB38	CHSTER32

HAAS

MOD: SL10/20/30

MODULO MOTORIZZATO ASSIALE DISASSATO 42mm VDI40

Axial driven tool re-directed by 42mm VDI40

Axial angetriebenes Werkzeug achsversetzt um 42mm VDI40

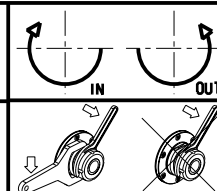

M.T. srl

Via Casino Albini 480
Tel. 0541/956034-957884
Fax 0541/956341

47842 S. GIOVANNI IN M. (RN)
e-mail: mtma@mtmarchetti.com
http://www.mtmarchetti.com

PRODUZIONE MODULI ROTANTI



PAGINA HAS160-1-00

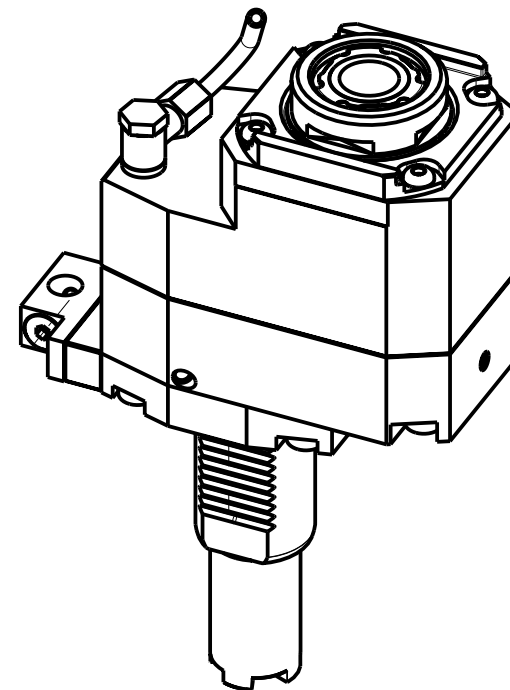
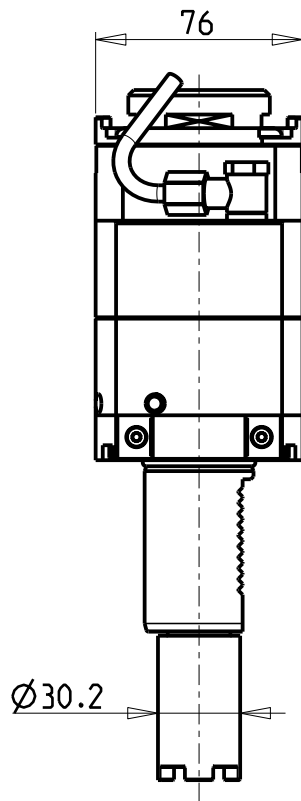
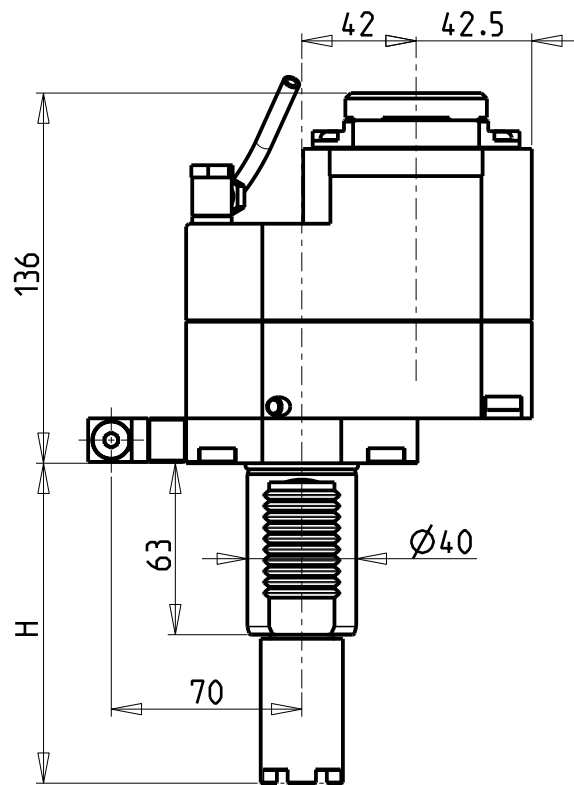

- Chiave inclusa
- Key included
- Schluessel inbegriffen

Cod. MT	Mandrino Spindle Spindel	I	RPM	Coppia Max Max Torque Max Drehmoment	Lubrificazione int. Coolant through Innenkühlung	Lubrificazione est. Ext. coolant Aussenkühlung	H	Tipo Torretta Turret Type Revolver Typ	CHIAVI NON INCLUSE Keys not included Schluessel nicht einbegriffen		
HAS0307132	ERA32	1:2	12000	45Nm	-	X	104.85	VDI STANDARD	C HUB30	CHTAER32ZC	OKU0650004
HAS0307232	ERA32	1:2	12000	45Nm	P=70bar	X	104.85	VDI STANDARD	C HUB30	CHTAER32ZC	OKU0650004
HAS0317132	ERA32	1:2	12000	45Nm	-	X	117.55	HYBRID 12 TURRET	C HUB30	CHTAER32ZC	OKU0650004
HAS0317232	ERA32	1:2	12000	45Nm	P=70bar	X	117.55	HYBRID 12 TURRET	C HUB30	CHTAER32ZC	OKU0650004

HAAS

MOD: SL10/20/30

MODULO MOTORIZZATO ASSIALE MOLTIPLICATO I=1:2 DISASSATO 42mm VDI40

Axial geared-up I=1:2 driven tool re-directed by 42mm VDI40

Axial angetriebenes Werkzeug uebersetzt I=1:2 achsversetzt um 42mm VDI40

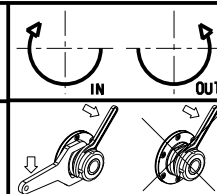

M.T. srl

Via Casino Albini 480
Tel. 0541/956034-957884
Fax 0541/956341

47842 S. GIOVANNI IN M. (RN)
e-mail: mtma@mtmarchetti.com
http://www.mtmarchetti.com

PRODUZIONE MODULI ROTANTI



PAGINA HAS160-1-20

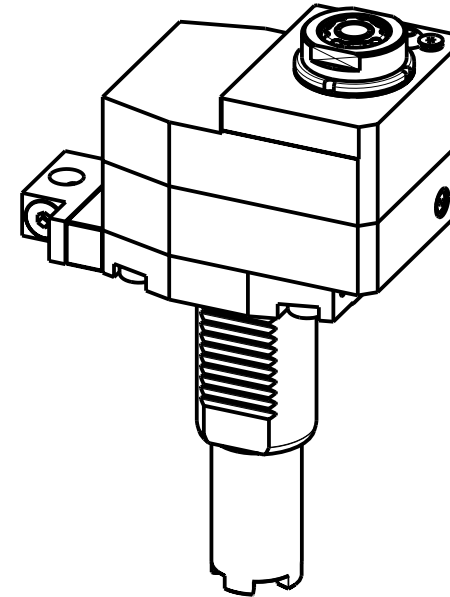
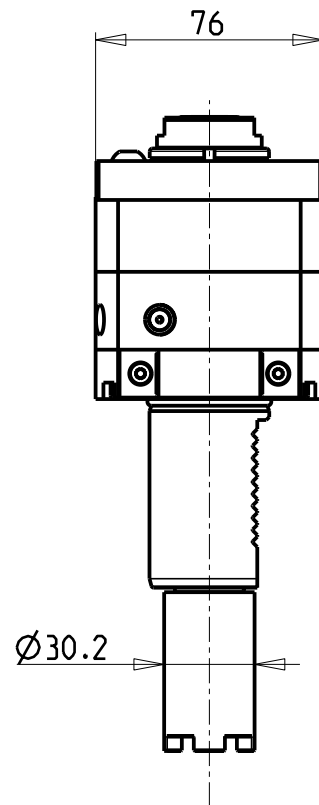
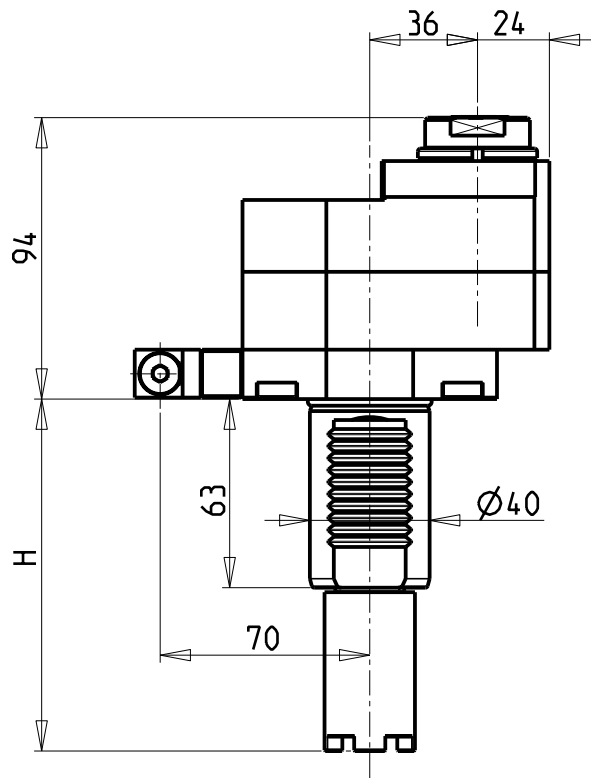

- Chiave inclusa
- Key included
- Schluessel inbegriffen

Cod. MT	Mandrino Spindle Spindel	I	RPM	Coppia Max Max Torque Max Drehmoment	Lubrificazione int. Coolant through Innenkuhlung	Lubrificazione est. Ext. coolant Aussenkuhlung	H	Tipo Torretta Turret Type Revolver Typ	CHIAVI NON INCLUSE Keys not included Schluessel nicht einbegriffen			
HAS0390116	ERA16	1:3	18000	10Nm	-	X	104.85	VDI STANDARD	C HUB30	C HUB19_SP3	C HTAER16ZC	▪
HAS0390216	ERA16	1:3	18000	10Nm	P=70bar	X	104.85	VDI STANDARD	C HUB30	C HUB19_SP3	C HTAER16ZC	▪
HAS0380116	ERA16	1:3	18000	10Nm	-	X	117.55	HYBRID 12 TURRET	C HUB30	C HUB19_SP3	C HTAER16ZC	▪
HAS0380216	ERA16	1:3	18000	10Nm	P=70bar	X	117.55	HYBRID 12 TURRET	C HUB30	C HUB19_SP3	C HTAER16ZC	▪

HAAS
 MOD: SL10/20/30
 MODULO MOTORIZZATO ASSIALE MOLTIPLICATO I=1:3 DISASSATO 36mm VDI40
 Axial geared-up I=1:3 driven tool re-directed by 36mm VDI40
 Axial angetriebenes Werkzeug uebersetzt I=1:3 achsversetzt um 36mm VDI40

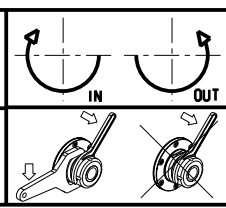

M.T. srl
 Via Casino Albini 480
 Tel. 0541/956034-957884
 Fax 0541/956341
 47842 S. GIOVANNI IN M. (RN)
 e-mail: mtma@mtmarchetti.com
 http://www.mtmarchetti.com

PRODUZIONE MODULI ROTANTI

PAGINA HAS160-1-30

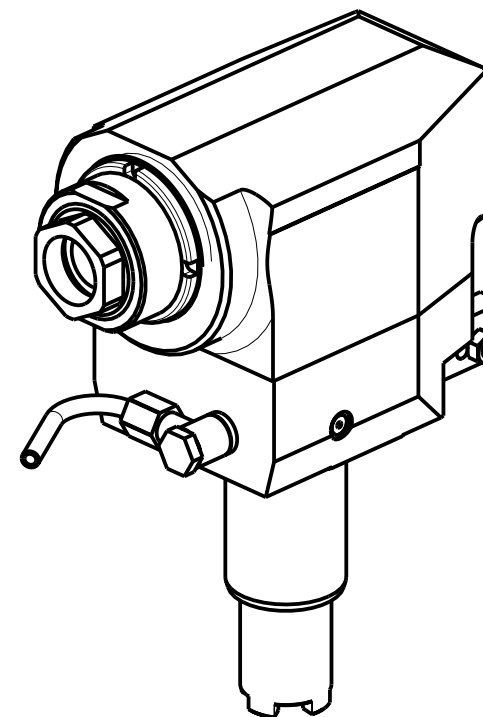
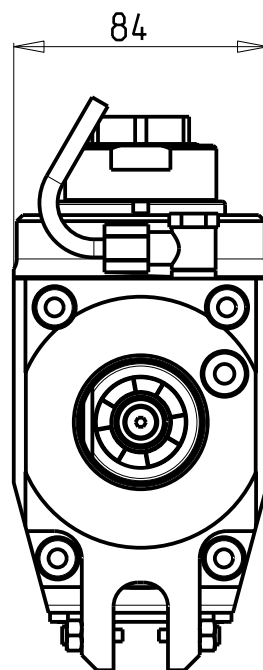
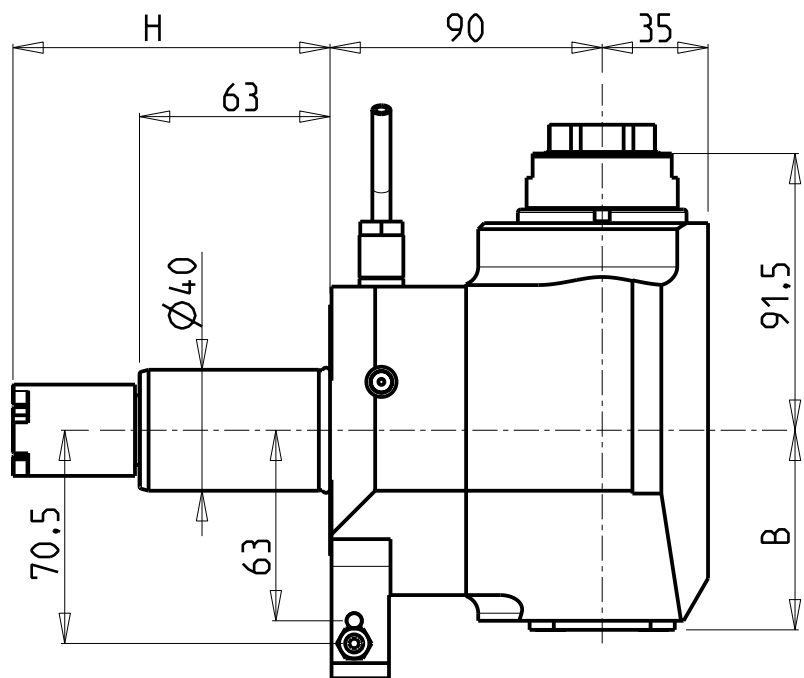

Cod. MT	Mandrino Spindle Spindel	I	RPM	Coppia Max Max Torque Max Drehmoment	Lubrificazione int. Coolant through Innenkühlung	Lubrificazione est. Ext. coolant Aussenkühlung	B	H	Tipo Torretta Turret type Revolver typ	CHIAVI NON INCLUSE Keys not included Schlüssel nicht einbegriffen	
HAS0150132	ERA32	1:2	12000	30Nm		X	66	104.85	VDI STANDARD	CHUB41	CHUB32
HAS0150232	ERA32	1:2	12000	30Nm	P=70bar	X	76	104.85	VDI STANDARD	CHUB41	CHUB32
HAS0160132	ERA32	1:2	12000	30Nm		X	66	117.55	HYBRID 12 TURRET	CHUB41	CHUB32
HAS0160232	ERA32	1:2	12000	30Nm	P=70bar	X	76	117.55	HYBRID 12 TURRET	CHUB41	CHUB32

HAAS

MOD: SL10/20/30

MODULO MOTORIZZATO RADIALE MOLTIPLICATO I=1:2 VDI40

Radial geared-up I=1:2 driven tool VDI40

Radial angetriebenes Werkzeug uebersezt I=1:2 VDI40

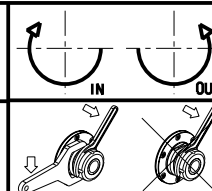

M.T. srl

Via Casino Albini 480
Tel. 0541/956034-957884

Fax 0541/956341

47842 S. GIOVANNI IN M. (RN)

e-mail: mtma@mtmarchetti.com

http://www.mtmarchetti.com

PRODUZIONE MODULI ROTANTI



PAGINA HAS203-1-10

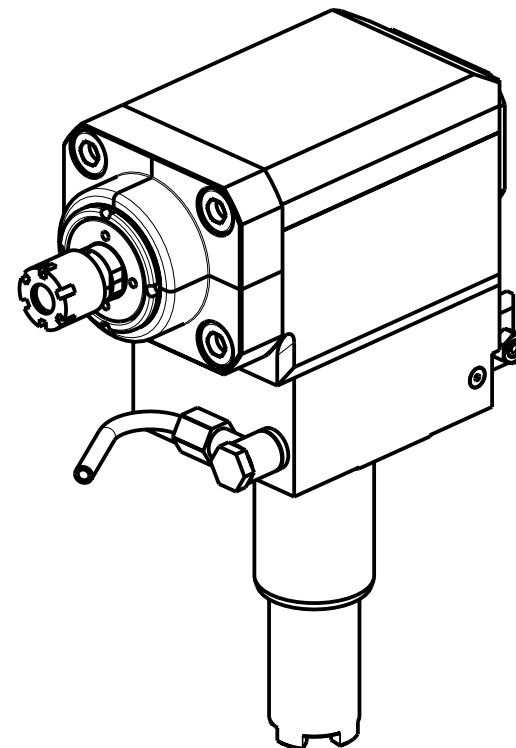
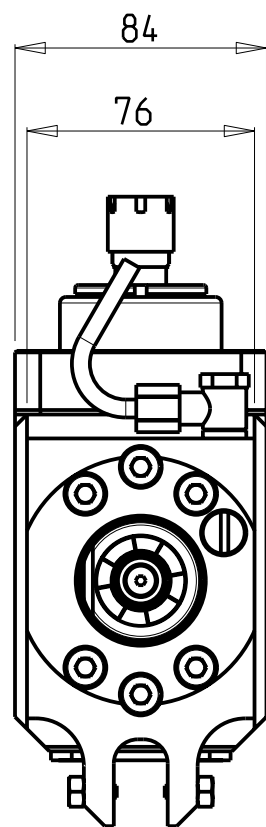
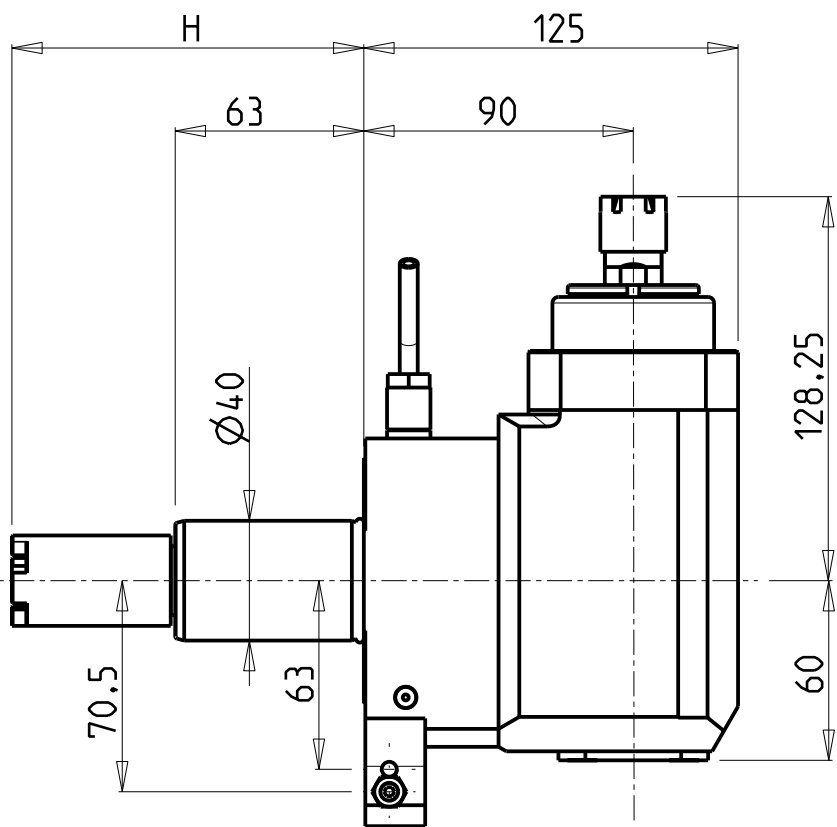

Cod. MT	Mandrino Spindle Spindel	I	RPM	Coppia Max Max Torque Max Drehmoment	Lubrificazione est. Ext. coolant Aussenkühlung	H	Tipo Torretta Turret type Revolver typ	CHIAVI INCLUSE Keys included Schlüssel einbegriffen	
HAS0330016	ER16	1:3	18000	10Nm	X	104.85	VDI STANDARD	CHUB17	CHMNER16
HAS0340016	ER16	1:3	18000	10Nm	X	117.55	HYBRID 12 TURRET	CHUB17	CHMNER16

HAAS
MOD: SL10/20/30

MODULO MOTORIZZATO RADIALE MOLTIPLICATO I=1:3 VDI40
Radial geared-up I=1:3 driven tool VDI40
Radial angetriebenes Werkzeug uebersezt I=1:3 VDI40

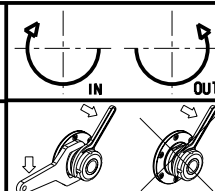

M.T. srl
Via Casino Albini 480
Tel. 0541/956034-957884
Fax 0541/956341
47842 S. GIOVANNI IN M. (RN)
e-mail: mtma@mtmarchetti.com
http://www.mtmarchetti.com

PRODUZIONE MODULI ROTANTI



PAGINA HAS208-1-10

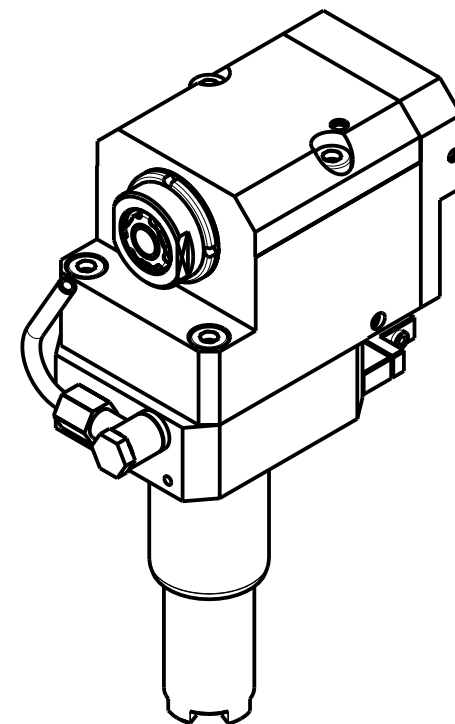
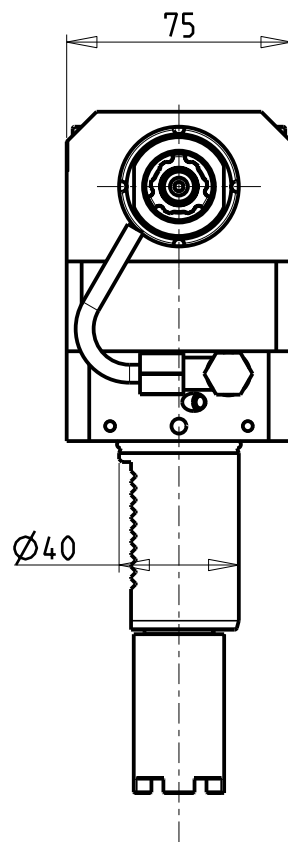
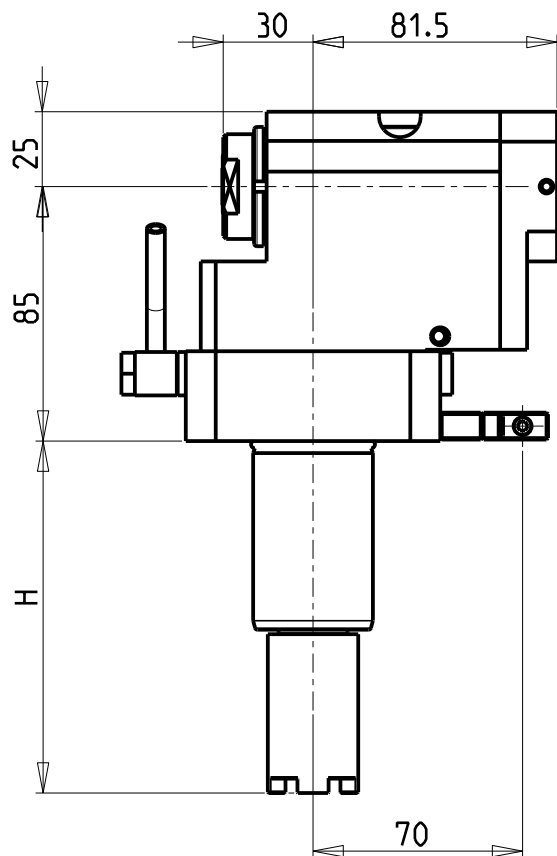

- Chiave inclusa
- Key included
- Schlüssel inbegriffen

Cod. MT	Mandrino Spindle Spindel	I	RPM	Coppia Max Max Torque Max Drehmoment	Lubrificazione int. Coolant through Innenkühlung	Lubrificazione est. Ext. coolant AusSENKühlung	H	Tipo Torretta Turret Type Revolver Typ	CHIAVI NON INCLUSE Keys not included Schlüssel nicht einbegriffen		
									C HUB30	C HUB19_SP3	C HTAER16ZC
HAS0420116	ERA16	1:3	18000	10Nm	-	X	104.85	VDI STANDARD	C HUB30	C HUB19_SP3	C HTAER16ZC
HAS0420216	ERA16	1:3	18000	10Nm	P=70bar	X	104.85	VDI STANDARD	C HUB30	C HUB19_SP3	C HTAER16ZC
HAS0410116	ERA16	1:3	18000	10Nm	-	X	117.55	HYBRID 12 TURRET	C HUB30	C HUB19_SP3	C HTAER16ZC
HAS0410216	ERA16	1:3	18000	10Nm	P=70bar	X	117.55	HYBRID 12 TURRET	C HUB30	C HUB19_SP3	C HTAER16ZC

HAAS

MOD: SL10/20/30

MODULO MOTORIZZATO RADIALE ARRETRATO MOLTIPLICATO I=1:3 VDI40

Radial geared-up I=1:3 rear-set driven tool VDI40

Radial angetriebenes Werkzeug uebersezt I=1:3 zurueckversetzt VDI40

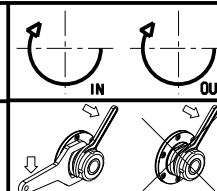

M.T. srl

Via Casino Albini 480
Tel. 0541/956034-957884

Fax 0541/956341

47842 S. GIOVANNI IN M. (RN)

e-mail: mtma@mtmarchetti.com

http://www.mtmarchetti.com

PRODUZIONE MODULI ROTANTI



PAGINA HAS226-1-10

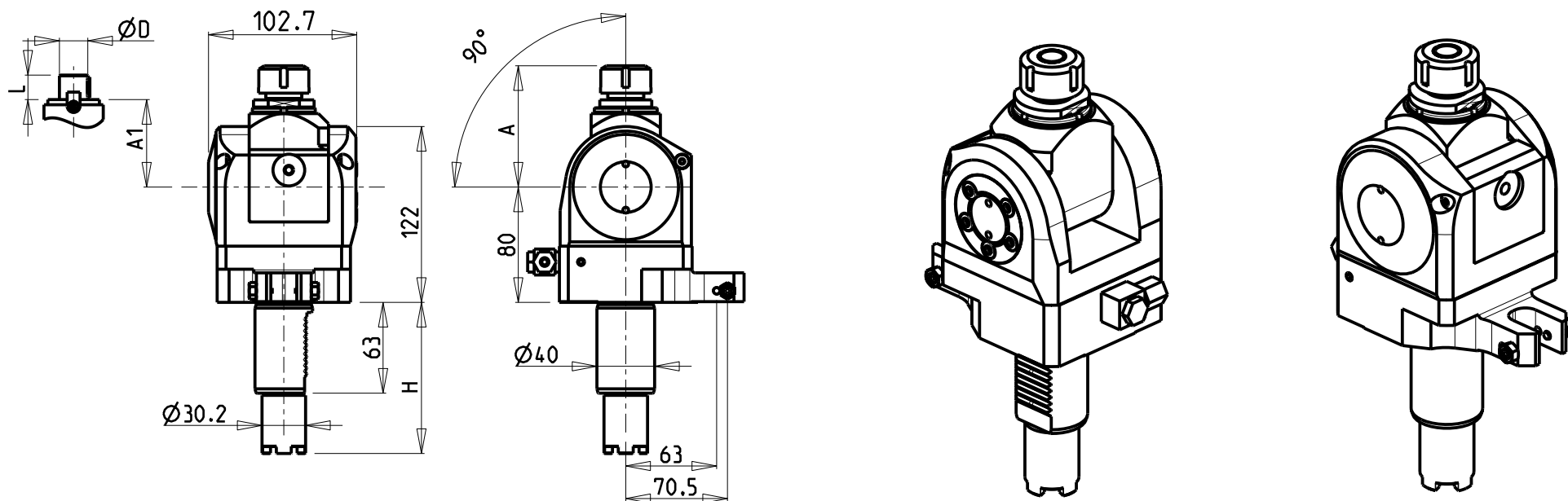

Cod. MT	Mandrino Spindel Spindel	I	RPM	Coppia Max Max Torque Max Drehmoment	Lubrificazione est. Ext. coolant Aussekkuehlung	A	A1	D	L	H	Tipo Torretta Turret Type Revolver Typ	CHIAVI INCLUSE Keys included Schluessel inbegriffen	
HAS0050020	ER20	1:1	6000	40Nm	X	84.16	-	-	-	104.85	VDI STANDARD	CHUB36	CHSTER20
HAS0060020	ER20	1:1	6000	40Nm	X	84.16	-	-	-	117.55	HYBRID 12 TURRET	CHUB36	CHSTER20
HAS0050025	ER25	1:1	6000	40Nm	X	85.66	-	-	-	104.85	VDI STANDARD	CHUB36	CHSTER25
HAS0060025	ER25	1:1	6000	40Nm	X	85.66	-	-	-	117.55	HYBRID 12 TURRET	CHUB36	CHSTER25
HAS0051617	Ø16x17	1:1	6000	40Nm	X	-	65	16	17	104.85	VDI STANDARD	CHUB36	CH_VTCROCE_M08
HAS0061617	Ø16x17	1:1	6000	40Nm	X	-	65	16	17	117.55	HYBRID 12 TURRET	CHUB36	CH_VTCROCE_M08
HAS0052219	Ø22x19	1:1	6000	40Nm	X	-	66	22	19	104.85	VDI STANDARD	CHUB36	CH_VTCROCE_M10
HAS0062219	Ø22x19	1:1	6000	40Nm	X	-	66	22	19	117.55	HYBRID 12 TURRET	CHUB36	CH_VTCROCE_M10
HAS0051905	Ø3/4"x3/4"	1:1	6000	40Nm	X	-	65	3/4"	3/4"	104.85	VDI STANDARD	CHUB36	CH_VTCROCE_M08
HAS0061905	Ø3/4"x3/4"	1:1	6000	40Nm	X	-	65	3/4"	3/4"	117.55	HYBRID 12 TURRET	CHUB36	CH_VTCROCE_M08

HAAS

MOD: SL10/20/30

MODULO MOTORIZZATO ORIENTABILE 0-90° VDI40

0-90° adjustable angle driven tool VDI40

Angetriebenes Werkzeug schwenkbar 0-90° VDI40

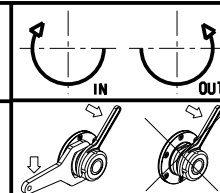

M.T. srl

Via Casino Albini 480
Tel. 0541/956034-957884

Fax 0541/956341

47842 S. GIOVANNI IN M. (RN)

e-mail: mtma@mtmarchetti.com

http://www.mtmarchetti.com

PRODUZIONE MODULI ROTANTI



PAGINA HAS330-1-00

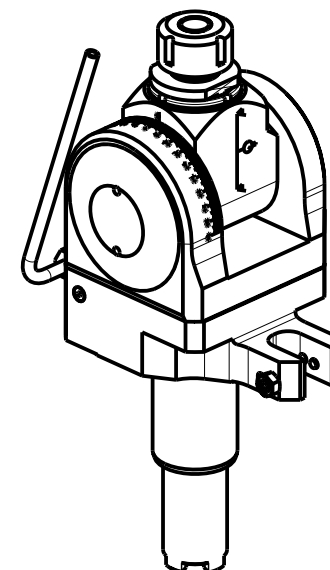
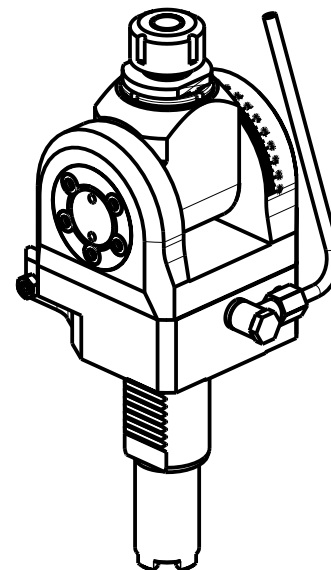
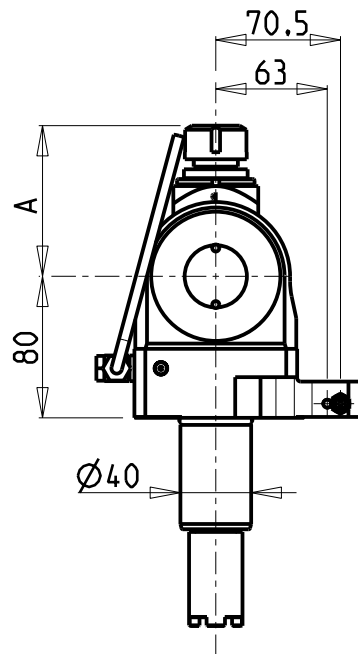
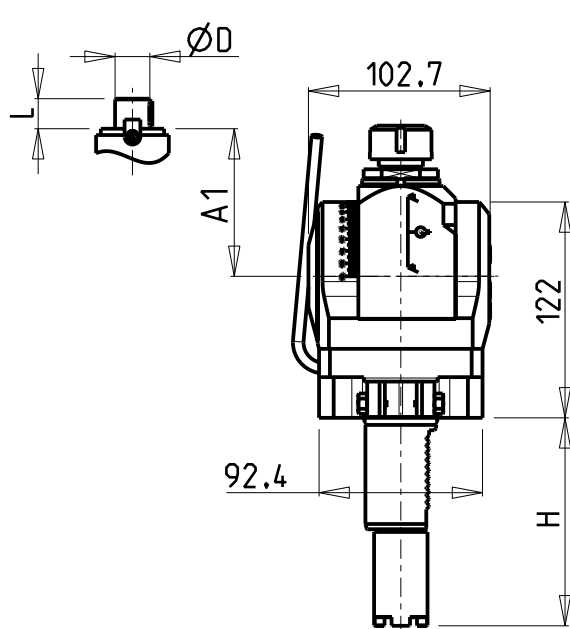

Cod. MT	Mandrino Spindle Spindel	I	RPM	Coppia Max Max Torque Max Drehmoment	Lubrificazione est. Ext. coolant Ausseukuehlung	A	A1	D	L	H	Tipo Torretta Turret Type Revolver Typ	CHIAVI INCLUSE Keys included Schluessel inbegriffen		
HAS0470120	ER20	1:1	6000	40Nm	X	85.16	-	-	-	104.85	VDI STANDARD	CHUB36	CHSTER20	NEW
HAS0480120	ER20	1:1	6000	40Nm	X	85.16	-	-	-	117.55	HYBRID 12 TURRET	CHUB36	CHSTER20	NEW
HAS0470125	ER25	1:1	6000	40Nm	X	86.16	-	-	-	104.85	VDI STANDARD	CHUB36	CHSTER25	NEW
HAS0480125	ER25	1:1	6000	40Nm	X	86.16	-	-	-	117.55	HYBRID 12 TURRET	CHUB36	CHSTER25	NEW
HAS0470516	Ø16x17	1:1	6000	40Nm	X	-	65	16	17	104.85	VDI STANDARD	CHUB36	CH_VTCROCE_M08	NEW
HAS0480516	Ø16x17	1:1	6000	40Nm	X	-	65	16	17	117.55	HYBRID 12 TURRET	CHUB36	CH_VTCROCE_M08	NEW
HAS0470522	Ø22x19	1:1	6000	40Nm	X	-	66	22	19	104.85	VDI STANDARD	CHUB36	CH_VTCROCE_M10	NEW
HAS0480522	Ø22x19	1:1	6000	40Nm	X	-	66	22	19	117.55	HYBRID 12 TURRET	CHUB36	CH_VTCROCE_M10	NEW
HAS0470519	Ø3/4"x3/4"	1:1	6000	40Nm	X	-	65	3/4"	3/4"	104.85	VDI STANDARD	CHUB36	CH_VTCROCE_M08	NEW
HAS0480519	Ø3/4"x3/4"	1:1	6000	40Nm	X	-	65	3/4"	3/4"	117.55	HYBRID 12 TURRET	CHUB36	CH_VTCROCE_M08	NEW

HAAS
MOD: SL10/20/30

MODULO MOTORIZZATO ORIENTABILE ±90° VDI40
±90° adjustable angle driven tool VDI40
Angetriebenes Werkzeug schwenkbar ±90° VDI40

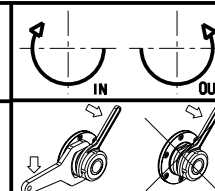

M.T. srl

Via Casino Albini 480
Tel. 0541/956034-957884
Fax 0541/956341
47842 S. GIOVANNI IN M. (RN)
e-mail: mtma@mtmarchetti.com
http://www.mtmarchetti.com

PRODUZIONE MODULI ROTANTI



PAGINA HAS333-1-00

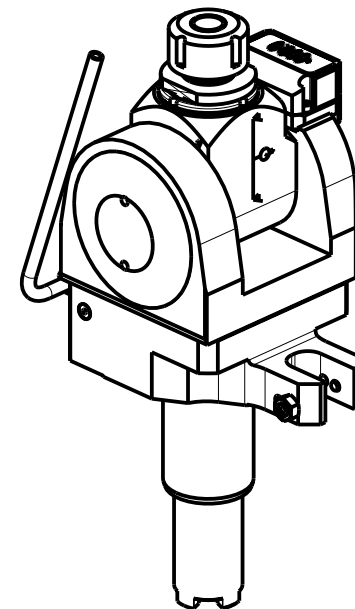
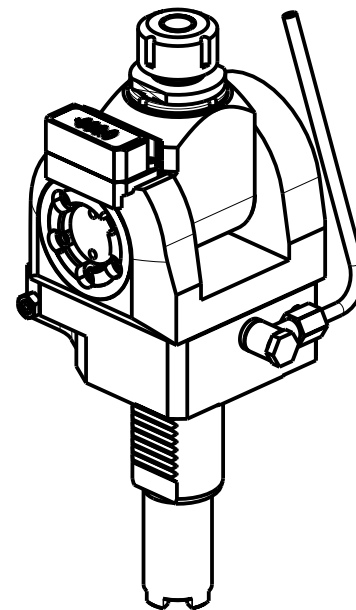
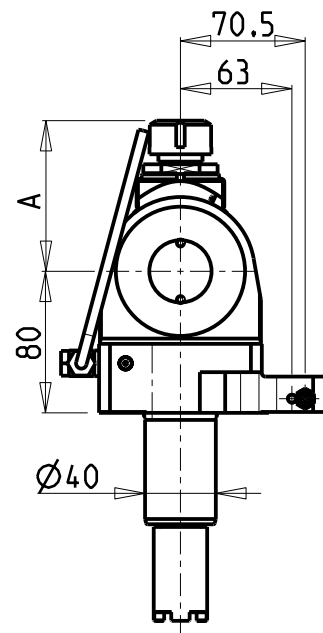
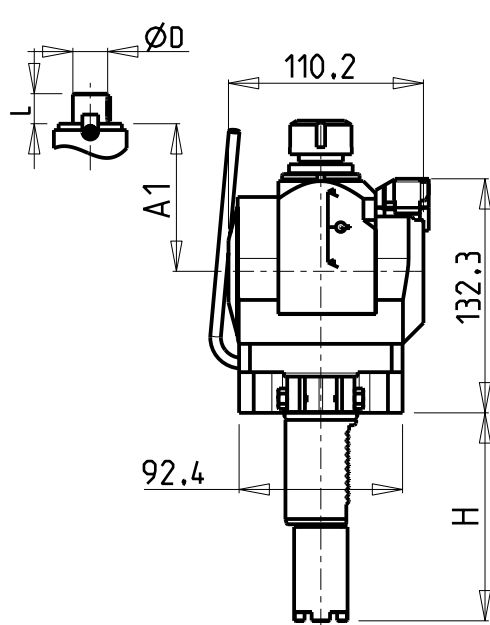

Cod. MT	Mandrino Spindle Spindel	I	RPM	Coppia Max Max Torque Max Drehmoment	Lubrificazione est. Ext. coolant Ausseukuehlung	A	A1	D	L	H	Tipo Torretta Turret Type Revolver Typ	CHIAVI INCLUSE Keys included Schluessel inbegriffen	
HAS0440120	ER20	1:1	6000	40Nm	X	85.16	-	-	-	104.85	VDI STANDARD	CHUB36	CHSTER20
HAS0450120	ER20	1:1	6000	40Nm	X	85.16	-	-	-	117.55	HYBRID 12 TURRET	CHUB36	CHSTER20
HAS0440125	ER25	1:1	6000	40Nm	X	86.16	-	-	-	104.85	VDI STANDARD	CHUB36	CHSTER25
HAS0450125	ER25	1:1	6000	40Nm	X	86.16	-	-	-	117.55	HYBRID 12 TURRET	CHUB36	CHSTER25
HAS0440516	Ø16x17	1:1	6000	40Nm	X	-	65	16	17	104.85	VDI STANDARD	CHUB36	CH_VTCROCE_M08
HAS0450516	Ø16x17	1:1	6000	40Nm	X	-	65	16	17	117.55	HYBRID 12 TURRET	CHUB36	CH_VTCROCE_M08
HAS0440522	Ø22x19	1:1	6000	40Nm	X	-	66	22	19	104.85	VDI STANDARD	CHUB36	CH_VTCROCE_M10
HAS0450522	Ø22x19	1:1	6000	40Nm	X	-	66	22	19	117.55	HYBRID 12 TURRET	CHUB36	CH_VTCROCE_M10
HAS0440519	Ø3/4"x3/4"	1:1	6000	40Nm	X	-	65	3/4"	3/4"	104.85	VDI STANDARD	CHUB36	CH_VTCROCE_M08
HAS0450519	Ø3/4"x3/4"	1:1	6000	40Nm	X	-	65	3/4"	3/4"	117.55	HYBRID 12 TURRET	CHUB36	CH_VTCROCE_M08

HAAS

MOD: SL10/20/30

MODULO MOTORIZZATO ORIENTABILE ±90° CON NONIO DIGITALE VD140
 ±90° adjustable angle driven tool with digital display VD140
 Angetriebenes Werkzeug schwenkbar ±90° mit digital display VD140

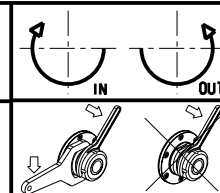

M.T. srl

Via Casino Albini 480
 Tel. 0541/956034-957884
 Fax 0541/956341

47842 S. GIOVANNI IN M. (RN)
 e-mail: mtma@mtmarchetti.com
 http://www.mtmarchetti.com

PRODUZIONE MODULI ROTANTI



PAGINA HAS333-1-01

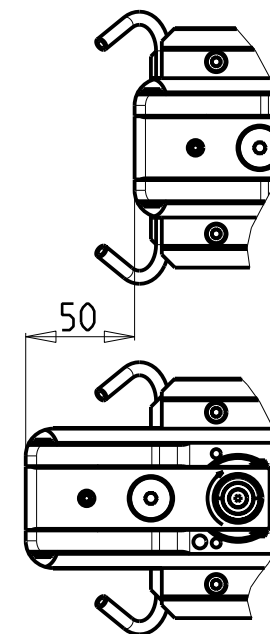
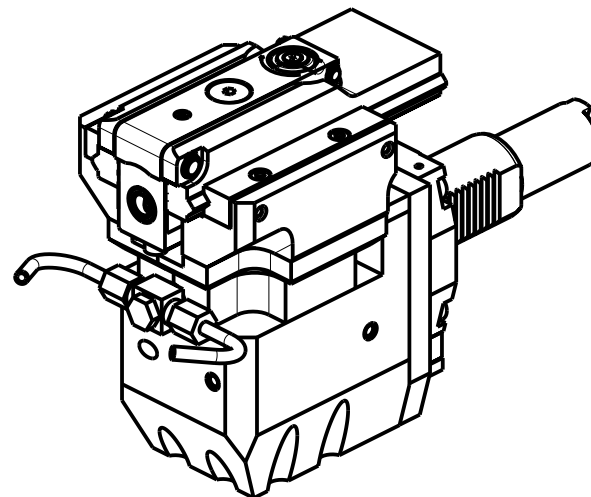
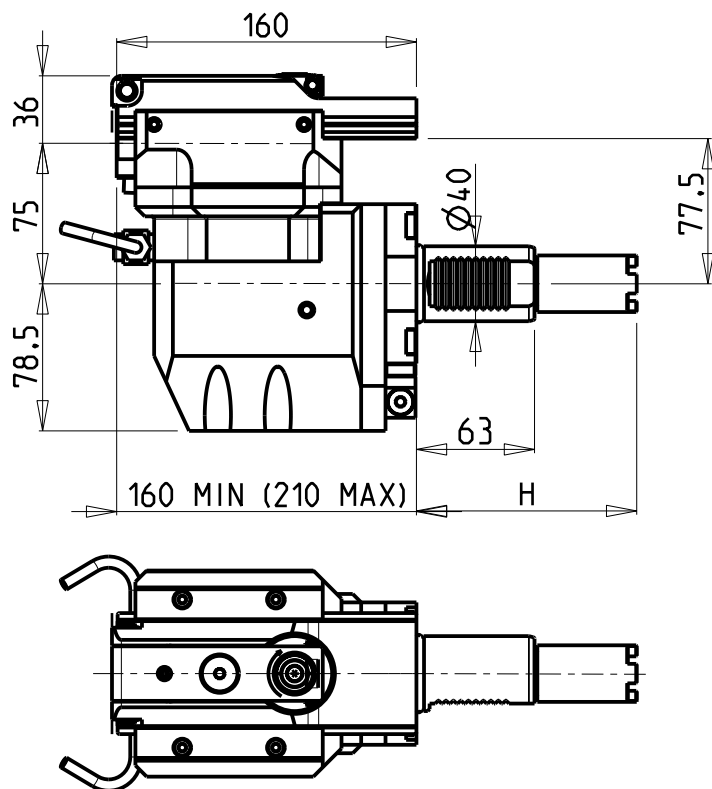
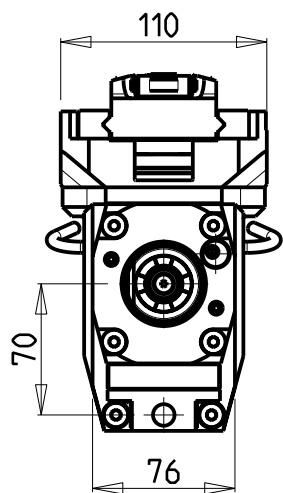

PER UTENSILI STOZZATORI VEDI PAG. TBL400-1-00
 FOR DRIVEN SLOTTING TOOL CUTTING-TOOLS SEE PAGE TBL400-1-00
 FÜR NUTENSTOSS-WERKZEUG SCHNEIDWERKZEUGE SIEHE SEITE TBL400-1-00

Cod. MT	I	RPM MAX	Lubr. esterna Ext. coolant Aussenkuehlung	H	Tipo Torretta Turret type Revolver typ
HAS0360100	4:1	2000	X	104.85	VDI STANDARD
HAS0350100	4:1	2000	X	117.55	HYBRID 12 TURRET

HAAS

MOD: SL10/20/30

MODULO MOTORIZZATO STOZZATORE CORSA 50mm VDI40

Slotting driven tool 50mm stroke VDI40

Keilnutenstossmaschine 50mm Hub VDI40

M.T. srl

Via Casino Albini 480
 Tel. 0541/956034-957884
 Fax 0541/956341
 47842 S. GIOVANNI IN M. (RN)
 e-mail: mtma@mtmarchetti.com
 http://www.mtmarchetti.com

PRODUZIONE MODULI ROTANTI



PAGINA HAS360-1-30

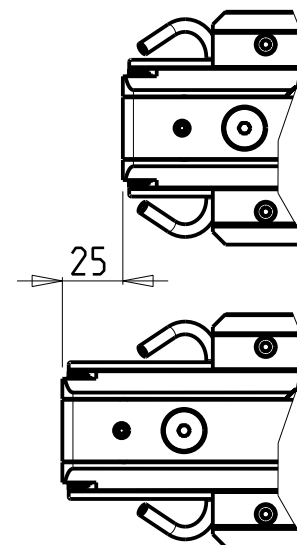
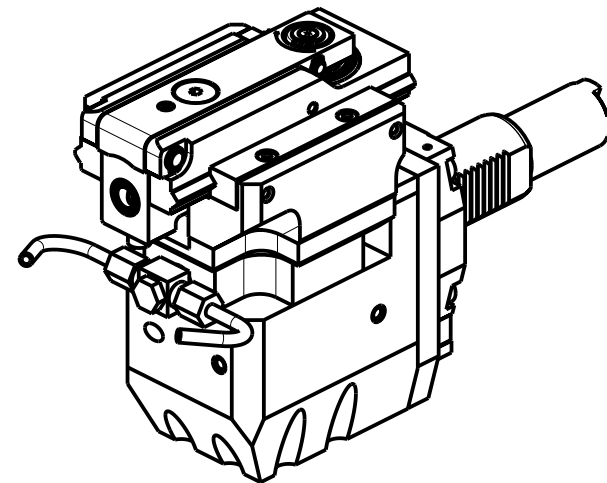
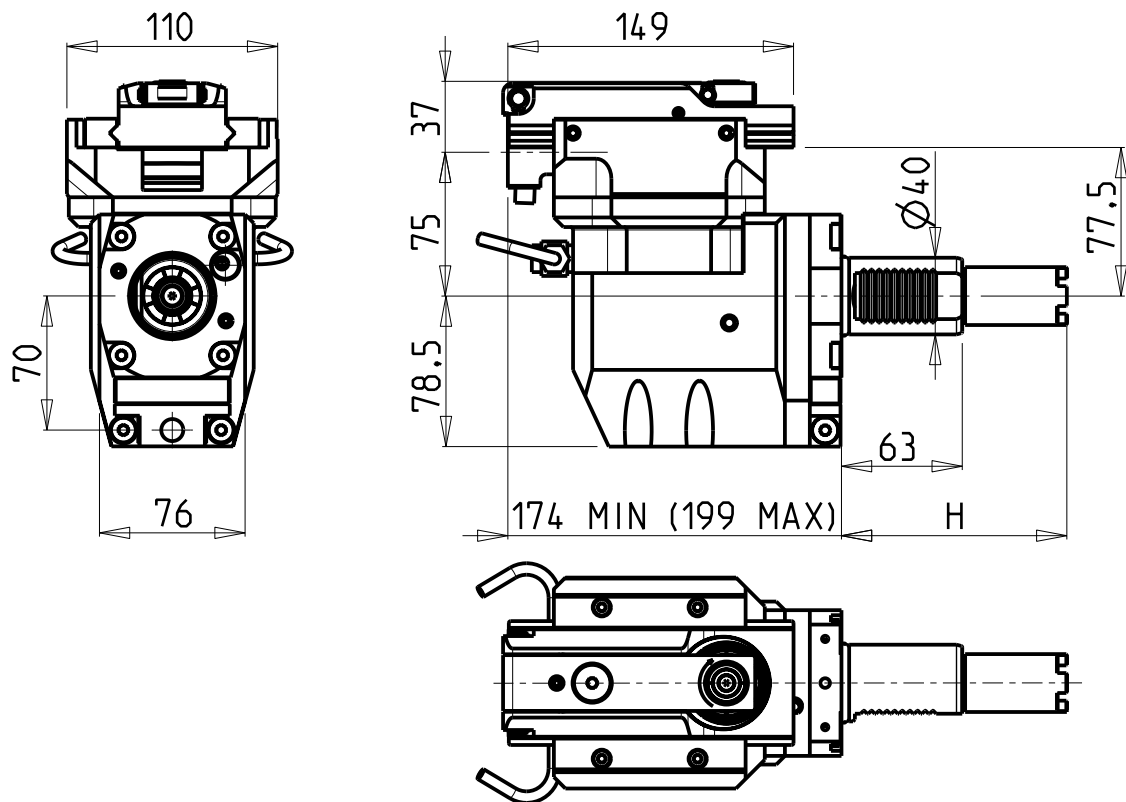

PER UTENSILI STOZZATORI VEDI PAG. TBL400-1-00
 FOR DRIVEN SLOTTING TOOL CUTTING-TOOLS SEE PAGE TBL400-1-00
 FÜR NUTENSTOSS-WERKZEUG SCHNEIDWERKZEUGE SIEHE SEITE TBL400-1-00

Cod. MT	I	RPM MAX	Lubr. esterna Ext. coolant Aussenkuehlung	H	Tipo Torretta Turret type Revolver typ
HAS0360200	4:1	2400	X	104.85	VDI STANDARD
HAS0350200	4:1	2400	X	117.55	HYBRID 12 TURRET

HAAS

MOD: SL10/20/30

MODULO MOTORIZZATO STOZZATORE CORSA 25mm VDI40

Slotting driven tool 25mm stroke VDI40

Keilnutenstossmaschine 25mm Hub VDI40

M.T. srl

Via Casino Albini 480
 Tel. 0541/956034-957884
 Fax 0541/956341
 47842 S. GIOVANNI IN M. (RN)
 e-mail: mtma@mtmarchetti.com
 http://www.mtmarchetti.com

PRODUZIONE MODULI ROTANTI



PAGINA HAS360-1-31

